



# SELECTING CHECK VALVES SELECCIÓN DE VÁLVULAS DE RETENCIÓN

		Sizes Medidas	PN	Body material Material cuerpo	Body O-rings Junta de cuerpo	Connection type Tipo conexión
 <p><b>SPRING SERIES</b> <i>SERIE MUELLE</i></p>	D16 - D63 ( $\frac{3}{8}$ " - 2")	PN 16 240 psi	PVC-U PVC-C	EPDM FPM	True union	
	D75 - D110 (2½" - 4")	PN 10 150 psi				
 <p><b>BALL SERIES</b> <i>SERIE BOLA</i></p>	D20 - D63 (½" - 2")	PN 16 240 psi	PVC-U PVC-C	EPDM FPM	True union	
	D75 - D110 (2½" - 4")	PN 10 150 psi				
 <p><b>SWING CHECK</b> <i>CLAPETA</i></p>	D75 - D315 (2½" - 12")	PN 6 90 psi	PVC-U	EPDM FPM	Flanges	
 <p><b>FOOT VALVES</b> <i>VÁLVULAS DE PIE</i></p>						

Concept  
&  
typical application

Shuts off flow by means of a cone pushed by a spring which helps it to obtain an entirely watertight closure.

The difference in pressure between two points of the installation is able to overcome the resistance of the spring, thus making the fluid flow in the desired direction and preventing the flow passage in the other.

**Transported material**

- Clean liquids, not viscous and without containing particles.

**Installation**

- Horizontal or vertical.

**Materials**

- Metallic spring (stainless steel).

**Piping**

- Moderated flows.

**Others**

- Very reliable closing.

Closing by means of a sphere which closes against a joint.

The ball closing is by gravity, which means that the most usual assembly position is vertical, with an inverse pressure at fluid presence.

**Transported material**

- Any type of liquid.

**Installation**

- Vertical, horizontal (see minimum pressure).

**Materials**

- Made completely in plastic.

**Piping**

- Ideally suited for large flows.

**Others**

- Minimum pressure loss.

The flap or disk has only one opening direction.

Installation takes up minimum space in the system.

**Transported material**

- Any type of liquid, it does not obstruct the passage of the fluid.

**Installation**

- Vertical, horizontal (see minimum pressure). Takes up minimum space in the system.

**Materials**

- All parts which are in contact with fluid are plastic.

**Piping**

- High flows.

**Others**

- Used for low pressures and big piping sizes.

## Foot valve operation

Foot valves are a particular type of check valves which are installed on the base of an aspiration pipe of a pump to prevent the impulsion pipe from emptying.

The valve must be installed between the pump and the tank in order to let the fluid access the pump and stopping it when returning to the tank.

The entry of the valve is protected by a screen filter to prevent the entry of unwanted elements which could exist in the tank or deposit.

Concepto  
y  
aplicaciones típicas

Cierre por medio de un cono empujado por un muelle que la ayuda a realizar un cierre completamente estanco.

La diferencia de presión entre dos puntos de la instalación es capaz de vencer la resistencia del muelle, discurriendo así el fluido en el sentido previsto e impidiéndose el paso en sentido contrario.

**Material conducido**

- Líquidos limpios, no viscosos y sin partículas en suspensión.

**Instalación**

- Horizontal o vertical.

**Materiales**

- Muelle metálico (acero inoxidable).

**Conducciones**

- Caudales moderados.

**Otros**

- Cierre muy fiable.

Cierre por medio de una esfera que cierra contra una junta.

El cierre de la bola siempre es por gravedad, lo cual significa que la posición de montaje más usual es en circuitos verticales y con una presión inversa con presencia de fluido.

**Material conducido**

- Cualquier tipo de líquido.

**Instalación**

- Vertical, horizontal (consultar presión mínima).

**Materiales**

- Fabricada completamente en plástico.

**Conducciones**

- Ideal para altos caudales.

**Otros**

- Mínima pérdida de carga.

La clapeta o disco sólo tiene un sentido de apertura.

Instalación sin ocupar casi espacio del sistema.

**Material conducido**

- Cualquier tipo de líquido, no ofrece obstáculos al paso del fluido.

**Instalación**

- Vertical, horizontal (consultar presión mínima), usa poco espacio de instalación.

**Materiales**

- Partes en contacto con el fluido, de plástico.

**Conducciones**

- Caudales elevados.

**Otros**

- Usada para bajas presiones y diámetros muy grandes.

## Funcionamiento válvula de pie

Las válvulas de pie son un tipo particular de válvula de retención que se instala en la base de la tubería de aspiración de una bomba, para evitar que se produzca el vaciado de la conducción de impulsión.

La válvula se debe instalar entre la bomba y el tanque, permitiendo que el fluido acceda a la bomba e impidiendo que regrese al tanque.

La entrada de la válvula suele estar protegida con un filtro para impedir la entrada de elementos extraños que puedan existir en el depósito o pozo de aspiración.

## PVC-U CHECK VALVES - SPRING SERIES

### VÁLVULAS ANTI-RETORNO PVC-U - SERIE MUELLE



Sizes	Solvent cement D16 - D110 (DN10 - DN100) Threaded 3/8" - 4"	
Standards	Solvent socket - Metric, British standard, ASTM, JIS Threaded - BSP, NPT	EN ISO 1452, EN ISO 15493, BS 4346-1, ASTM D 2467, JIS K 6743 ISO 228-1, ASTM D 2464
Working pressure	@ 20°C (73°F)  D16-D63 (3/8" - 2"): PN 16 (240 psi) D75 - D110 (2 1/2" - 4"): PN 10 (150 psi)	
Minimum working pressure		
Materials	O-rings: EPDM / FPM	
Characteristics	<ul style="list-style-type: none"> <li>• <b>May be used either vertically and horizontally.</b></li> <li>• 100% factory tested.</li> <li>• Easy installation and maintenance.</li> <li>• Available in PVC-U and Corzan® PVC-C.</li> <li>• Resistance to many inorganic chemicals.</li> <li>• Excellent flow characteristics.</li> </ul>	<ul style="list-style-type: none"> <li>• <b>Se pueden usar indistintamente verticalmente o horizontalmente.</b></li> <li>• Probadas al 100% en fábrica.</li> <li>• Fácil instalación y mantenimiento.</li> <li>• Disponibles en PVC-U y Corzan® PVC-C.</li> <li>• Resistencia a múltiples sustancias químicas inorgánicas.</li> <li>• Excelentes características de conducción.</li> </ul>
Certifications / regulations	Check valve design regulation - ISO 16137:2006	

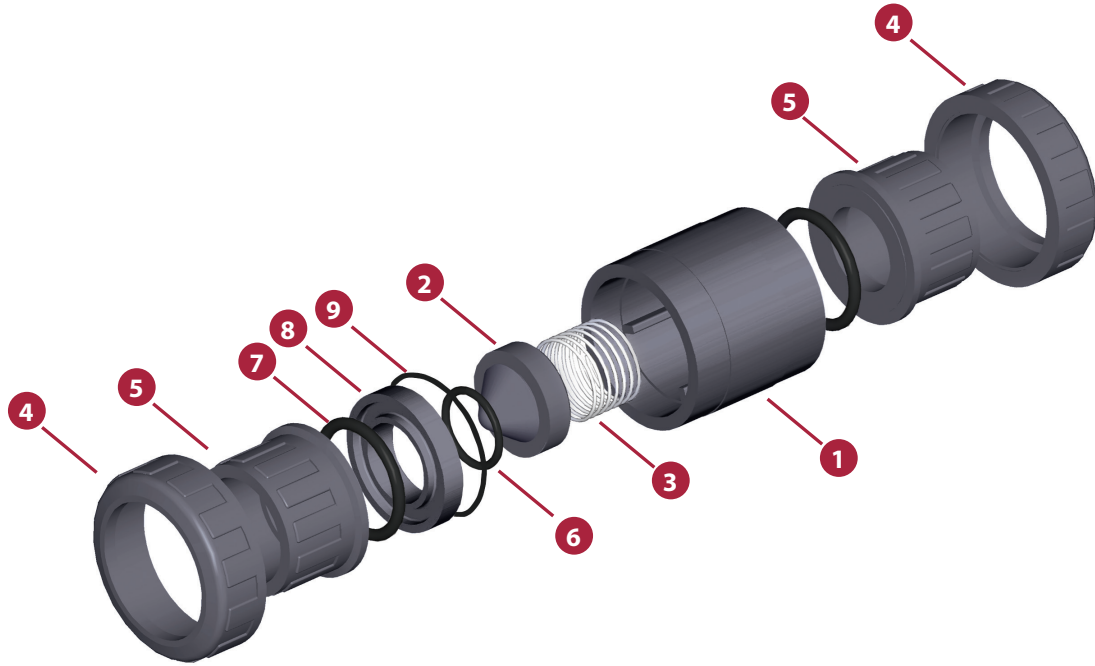
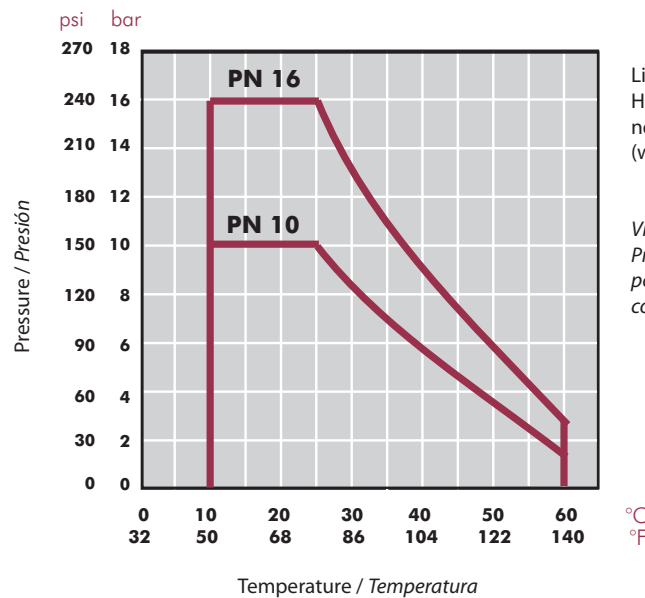

FIG.	Parts	Despiece	Material
1	Body	Cuerpo	PVC-U
2	Cone	Cono de cierre	PVC-U
3	Spring	Muelle	Stainless Steel AISI 302 / PTFE coated *
4	Union nut	Tuerca	PVC-U
5	End connector	Manguito enlace	PVC-U
6	Cone o-ring	Junta cono	EPDM / FPM
7	End connector o-ring	Junta manguito	EPDM / FPM
8	Seal-carrier	Portajuntas	PVC-U
9	Body o-ring	Junta cuerpo	EPDM / FPM

**PRESSURE / TEMPERATURE GRAPH**  
**DIAGRAMA PRESIÓN / TEMPERATURA**



Life: 25 years  
 Hydrostatic maximum pressure a component may withstand in continuous service (without overpressure)

Vida útil: 25 años  
 Presión hidrostática máxima que un componente es capaz de soportar en servicio continuo (sin sobrepresión)

**PRESSURE LOSS DIAGRAM**

**DIAGRAMA DE PÉRDIDAS DE CARGA**

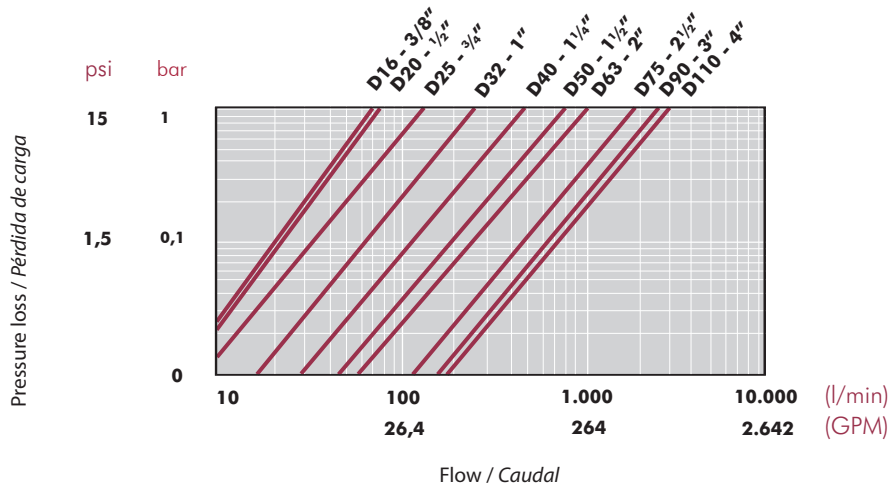

**RELATIVE FLOW**

**FLUJO RELATIVO**

D	20-1/2"	25-3/4"	32-1"	40-1 1/4"	50-1 1/2"	63-2"	75-2 1/2"	90-3"	110-4"
DN	15	20	25	32	40	50	65	80	100
Kv <sub>100</sub>	68	133	208	383	667	850	1533	1160	1200
Cv	5	9	15	27	47	60	107	81,2	84

$Cv = Kv_{100} / 14,28$   
 $Kv_{100}$  (l/min, Δp = 1 bar)  
 $Cv$  (GPM, Δp = 1 psi)

Relative flow in fully open valve (maximum opening)  
 Flujo relativo en válvula completamente abierta (apertura máxima)

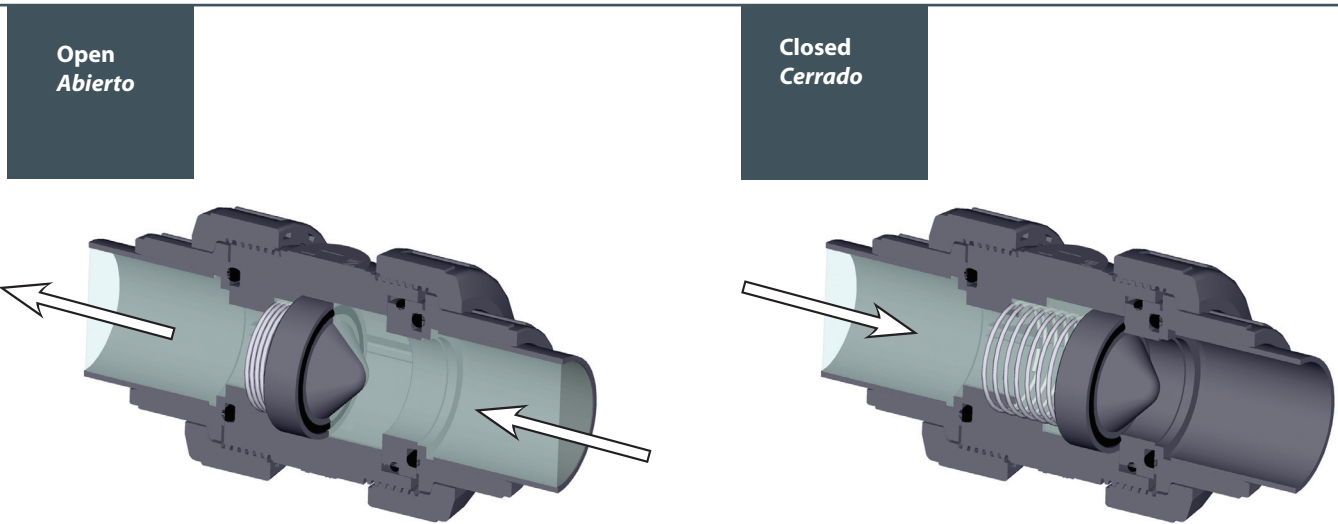

**OPENING PRESSURE**

**PRESIÓN DE APERTURA**

Minimum pressure: opening start  
 Maximum pressure: fully open valve

Presión mínima: inicio apertura  
 Presión máxima: válvula completamente abierta

D	P (bar) Minimum opening	P (bar) Maximum opening	P (psi) Minimum opening	P (psi) Maximum opening
20	0,11	0,19	1,57	2,71
25	0,035	0,067	0,5	0,95
32	0,042	0,077	0,6	1,1
40	0,038	0,069	0,54	0,98
50	0,063	0,088	0,9	1,25
63	0,038	0,060	0,54	0,85
75	0,031	0,060	0,44	0,85
90	0,025	0,060	0,35	0,85

### ASSEMBLY INSTRUCTIONS

#### Solvent socket or threaded unions

Loosen the valve union nuts (4) and separate these and the end connectors (5) from the valve body. Pass the pipe through the nuts and then place the bushes over the end of the pipe. The socket unions should be glued onto the pipe using a PVC-U or PVC-C adhesive and pressure should not be applied to the system until a drying period of at least 1 hour per bar of working pressure has elapsed. In the case of threaded unions, PTFE tape should be applied to the male threads. The pipes can now be attached to the valve by hand tightening down the nuts.

### INSTRUCCIONES DE MONTAJE

#### Uniones encoladas o roscadas

Afloje las tuercas (4) de la válvula y sepárelas de los manguitos (5). Introduzca las tuercas en los tubos y a continuación fije los manguitos en los extremos del tubo. Las uniones encoladas se realizarán con un adhesivo para tubos de PVC-U o PVC-C rígido y no se aplicará presión hasta transcurridas al menos 1 hora por bar. En las uniones roscadas se colocará cinta de PTFE en las roscas macho. A continuación ya podrá colocarse la válvula entre los manguitos y apretar a mano las tuercas sobre la válvula.

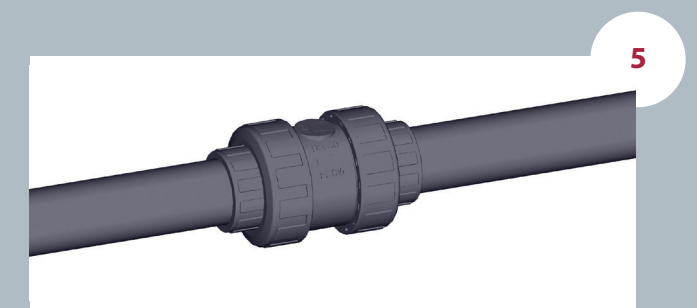
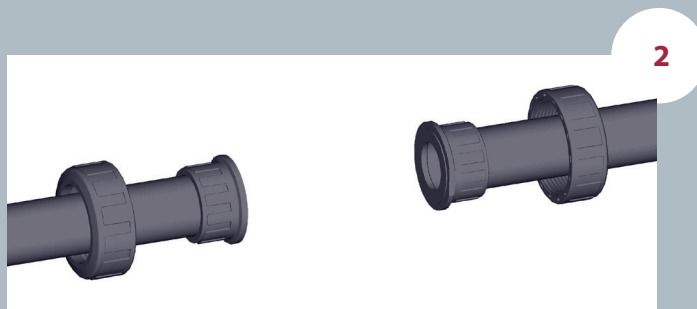
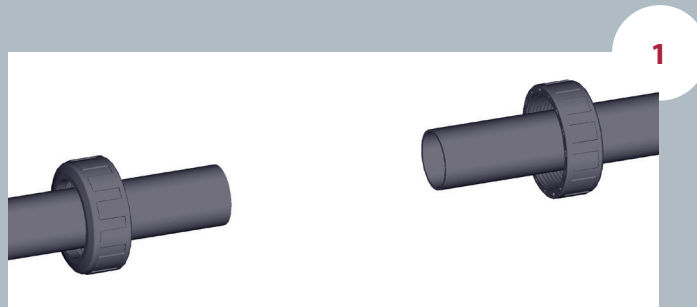

UP-S. 67. SF1 - SPRING CHECK VALVE

Spring check valve

- PVC-U body
- Female solvent socket
- Metric series
- O-Rings in EPDM

Válvula anti-retorno

- Cuerpo en PVC-U
- Encolar hembra
- Serie métrica
- Anillos tóricos en EPDM

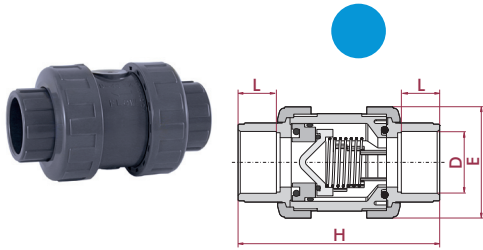

D	DN	PN	REF.	CODE
16	10	16	05 67 016	09010
20	15	16	05 67 020	09011
25	20	16	05 67 025	09012
32	25	16	05 67 032	09013
40	32	16	05 67 040	09014
50	40	16	05 67 050	09015
63	50	16	05 67 063	09016
75	65	10	05 67 075	09017
90	80	10	05 67 090	09018
110	80	10	05 67 110	09019
110	100	10	05 67 111	37076

L	H	E
14	84	52
16	84	52
19	108	62
22	119	70
26	142	84
31	162	94
38	192	117
44	232	148
51	269	179
61	279	179
61	279	179

UP-S. 67. FT1 - SPRING CHECK VALVE

Spring check valve

- PVC-U body
- BSP female thread
- O-Rings in EPDM

Válvula anti-retorno

- Cuerpo en PVC-U
- Roscar hembra BSP
- Anillos tóricos en EPDM

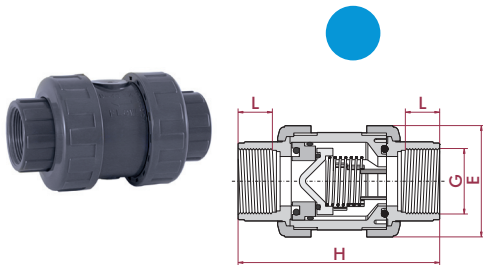

G	DN	PN	REF.	CODE
3/4"	10	16	05 67 616	09020
1/2"	15	16	05 67 620	09021
3/4"	20	16	05 67 625	09022
1"	25	16	05 67 632	09023
1 1/4"	32	16	05 67 640	09024
1 1/2"	40	16	05 67 650	09025
2"	50	16	05 67 663	09026
2 1/2"	65	10	05 67 675	09027
3"	80	10	05 67 690	09028
4"	80	10	05 67 710	09029
4"	100	10	05 67 711	37077

L	H	E
14	84	52
16	84	52
19	108	62
22	119	70
26	142	84
31	162	94
38	192	117
44	232	148
51	269	179
61	279	179
61	279	179

UP-S. 67. SF4 - SPRING CHECK VALVE

Spring check valve

- PVC-U body
- Female solvent socket
- Metric series
- O-Rings in FPM

Válvula anti-retorno

- Cuerpo en PVC-U
- Encolar hembra
- Serie métrica
- Anillos tóricos en FPM

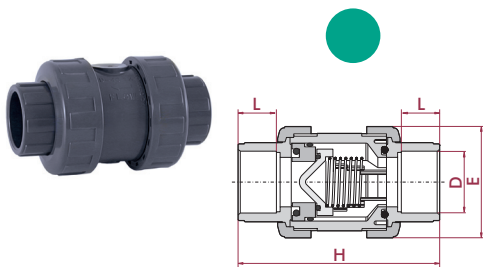

D	DN	PN	REF.	CODE
16	10	16	05 67 016 VI	18751
20	15	16	05 67 020 VI	18752
25	20	16	05 67 025 VI	18753
32	25	16	05 67 032 VI	18754
40	32	16	05 67 040 VI	18755
50	40	16	05 67 050 VI	18756
63	50	16	05 67 063 VI	18757
75	65	10	05 67 075 VI	18758
90	80	10	05 67 090 VI	18759
110	80	10	05 67 110 VI	18760
110	100	10	05 67 111 VI	62039

L	H	E
14	84	52
16	84	52
19	108	62
22	119	70
26	142	84
31	162	94
38	192	117
44	232	148
51	269	179
61	279	179
61	279	179

UP-S. 67. FT4 - SPRING CHECK VALVE

Spring check valve

- PVC-U body
- BSP female thread
- O-Rings in FPM

Válvula anti-retorno

- Cuerpo en PVC-U
- Roscar hembra BSP
- Anillos tóricos en FPM

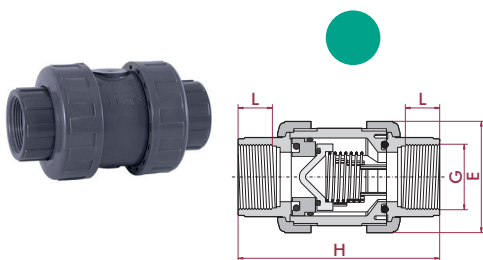

G	DN	PN	REF.	CODE
3/4"	10	16	05 67 616 VI	18761
1/2"	15	16	05 67 620 VI	18762
3/4"	20	16	05 67 625 VI	18763
1"	25	16	05 67 632 VI	18764
1 1/4"	32	16	05 67 640 VI	18765
1 1/2"	40	16	05 67 650 VI	18766
2"	50	16	05 67 663 VI	18767
2 1/2"	65	10	05 67 675 VI	18768
3"	80	10	05 67 690 VI	18769
4"	80	10	05 67 710 VI	18770
4"	100	10	05 67 711 VI	62040

L	H	E
14	84	52
16	84	52
19	108	62
22	119	70
26	142	84
31	162	94
38	192	117
44	232	148
51	269	179
61	279	179
61	279	179



## PVC-U FOOT VALVES - SPRING SERIES

### VÁLVULAS DE PIE PVC-U - SERIE MUELLE



Sizes	Solvent cement D16 - D110 (DN10 - DN100) Threaded 3/8" - 4"	
Standards	Solvent socket - Metric, British standard, ASTM, JIS Threaded - BSP, NPT	EN ISO 1452, EN ISO 15493, BS 4346-1, ASTM D 2467, JIS K 6743 ISO 228-1, ASTM D 2464
Working pressure	@ 20°C (73°F)  D16-D63 (3/8" - 2"): PN 16 (240 psi) D75 - D110 (2 1/2" - 4"): PN 10 (150 psi)	
Minimum working pressure		
Materials	O-rings: EPDM / FPM	
Characteristics	<ul style="list-style-type: none"> <li>• <b>May be used either vertically and horizontally.</b></li> <li>• 100% factory tested.</li> <li>• Easy installation and maintenance.</li> <li>• Available in PVC-U.</li> <li>• Resistance to many inorganic chemicals.</li> <li>• Excellent flow characteristics.</li> </ul>	<ul style="list-style-type: none"> <li>• <b>Se pueden usar indistintamente verticalmente o horizontalmente.</b></li> <li>• Probadas al 100% en fábrica.</li> <li>• Fácil instalación y mantenimiento.</li> <li>• Disponibles en PVC-U.</li> <li>• Resistencia a múltiples sustancias químicas inorgánicas.</li> <li>• Excelentes características de conducción.</li> </ul>
Certifications / regulations	Check valve design regulation - ISO 16137:2006	

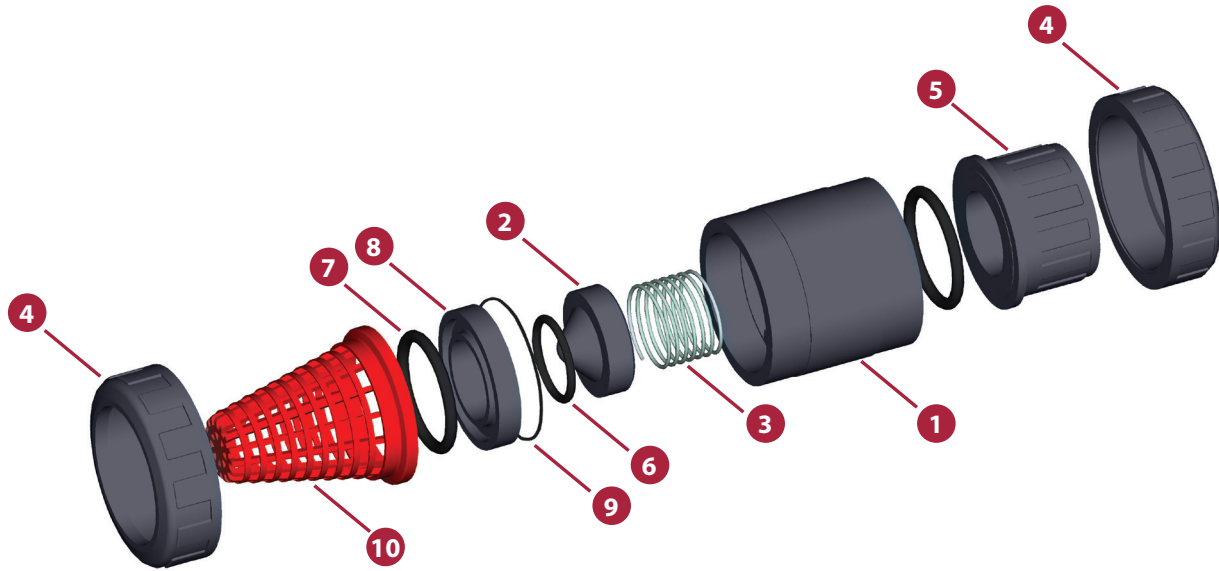
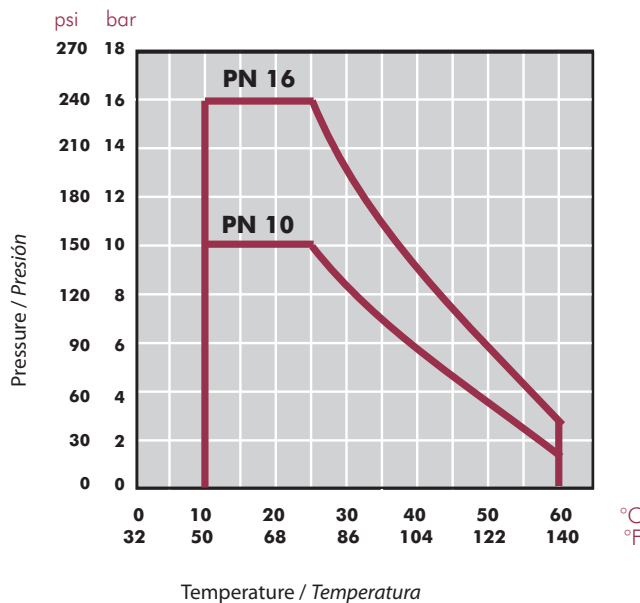

FIG.	Parts	Despiece	Material
1	Body	Cuerpo	PVC-U / PVC-C
2	Cone	Cono de cierre	PVC-U / PVC-C
3	Spring	Muelle	Staniless Steel AISI 302
4	Union nut	Tuerca	PVC-U / PVC-C
5	End connector	Manguito enlace	PVC-U / PVC-C
6	Cone o-ring	Junta cono	EPDM / FPM
7	End connector o-ring	Junta manguito	EPDM / FPM
8	Seal-carrier	Portajuntas	PVC-U / PVC-C
9	Body o-ring	Junta cuerpo	EPDM / FPM
10	Foot valve screen	Rejilla	PP

**PRESSURE / TEMPERATURE GRAPH**  
**DIAGRAMA PRESIÓN / TEMPERATURA**



Life: 25 years  
 Hydrostatic maximum pressure a component may withstand in continuous service (without overpressure)

Vida útil: 25 años  
 Presión hidrostática máxima que un componente es capaz de soportar en servicio continuo (sin sobrepresión)

**PRESSURE LOSS DIAGRAM**

**DIAGRAMA DE PÉRDIDAS DE CARGA**

D16 - 3/8"		D20 - 1/2"		D25 - 3/4"		D32 - 1"		D40 - 1 1/4"		D50 - 1 1/2"		D63 - 2"		D75 - 2 1/2"		D90 - 3"		D110 - 4"	
A	B	A	B	A	B	A	B	A	B	A	B	A	B	A	B	A	B	A	B
0,42	0,34	0,44	0,34	0,54	0,17	0,35	0,13	3,15	0,13	25,85	0,38	39,80	0,70	50,00	0,40	83,50	0,45	77,2	0,46
0,85	0,52	0,92	0,58	1,06	0,22	1,13	0,18	5,20	0,12	20,70	0,27	34,50	0,48	44,20	0,29	74,80	0,39	67,5	0,36
1,35	0,58	1,60	0,19	1,65	0,15	1,62	0,15	7,35	0,16	17,50	0,19	27,50	0,28	36,50	0,23	64,90	0,31	60,1	0,30
2,08	0,28	2,05	0,18	2,18	0,18	2,02	0,14	9,38	0,21	12,30	0,11	21,15	0,17	30,90	0,20	50,38	0,21	49,6	0,22
2,44	0,34	2,48	0,22	3,21	0,29	2,59	0,14	12,17	0,31	8,86	0,09	12,65	0,09	25,50	0,15	43,08	0,18	41,1	0,18
2,80	0,60	3,10	0,30	3,91	0,38	3,07	0,15	15,05	0,43	3,22	0,09	6,25	0,08	20,35	0,12	35,22	0,14	31,5	0,14
-	-	3,53	0,35	4,32	0,44	3,51	0,16	-	-	-	-	-	-	12,30	0,11	28,75	0,11	24,6	0,13
-	-	-	-	-	-	4,20	0,20	-	-	-	-	-	-	6,27	0,11	18,02	0,08	15,8	0,01
-	-	-	-	-	-	-	-	-	-	-	-	-	-	-	-	8,28	0,11	7,9	0,08
-	-	-	-	-	-	-	-	-	-	-	-	-	-	-	-	-	-	-	-

**A =** Flow (m<sup>3</sup>/h)  
Caudal (m<sup>3</sup>/h)

**B =** Pressure loss (bar)  
Pérdida de carga (bar)

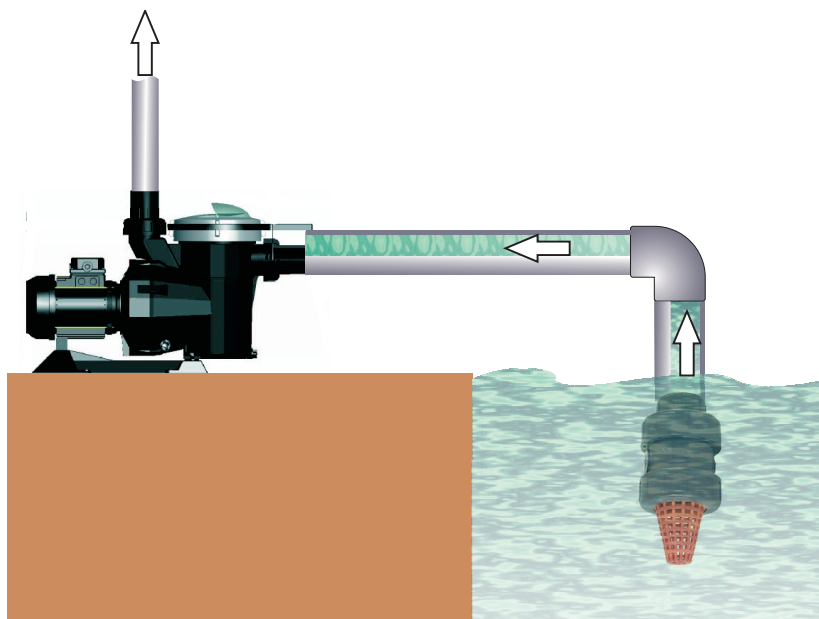

**OPENING PRESSURE**

**PRESIÓN DE APERTURA**

Minimum pressure: opening start  
Maximum pressure: fully open valve

Presión mínima: inicio apertura  
Presión máxima: válvula completamente abierta

D	P (bar) Minimum opening	P (bar) Maximum opening	P (PSI) Minimum opening	P (PSI) Maximum opening
20	0,11	0,19	1,57	2,71
25	0,035	0,067	0,5	0,95
32	0,042	0,077	0,6	1,1
40	0,038	0,069	0,54	0,98
50	0,063	0,088	0,9	1,25
63	0,038	0,060	0,54	0,85
75	0,031	0,060	0,44	0,85
90	0,025	0,060	0,35	0,85

**UP-S. 66. SF1 - SPRING FOOT CHECK VALVE**
**Foot valve**

- PVC-U body
- Female solvent socket
- Metric series
- O-Rings in EPDM

**Válvula de pie**

- Cuerpo en PVC-U
- Encolar hembra
- Serie métrica
- Anillos tóricos en EPDM

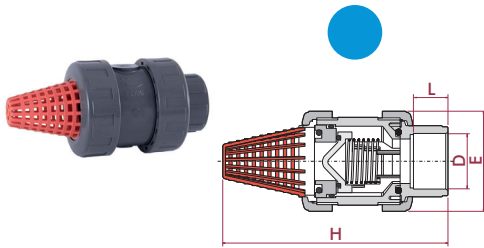

D	DN	PN	REF.	CODE
16	10	16	05 66 016	<b>08990</b>
20	15	16	05 66 020	<b>08991</b>
25	20	16	05 66 025	<b>08992</b>
32	25	16	05 66 032	<b>08993</b>
40	32	16	05 66 040	<b>08994</b>
50	40	16	05 66 050	<b>08995</b>
63	50	16	05 66 063	<b>08996</b>
75	65	10	05 66 075	<b>08997</b>
90	80	10	05 66 090	<b>08998</b>
110	80	10	05 66 110	<b>08999</b>

L	H	E
14	107	52
16	107	52
19	130	62
22	154	70
26	176	84
31	202	94
38	239	117
44	306	148
51	362	179
61	367	179

**UP-S. 66. FT1 - SPRING FOOT CHECK VALVE**
**Foot valve**

- PVC-U body
- BSP female thread
- O-Rings in EPDM

**Válvula de pie**

- Cuerpo en PVC-U
- Roscar hembra BSP
- Anillos tóricos en EPDM

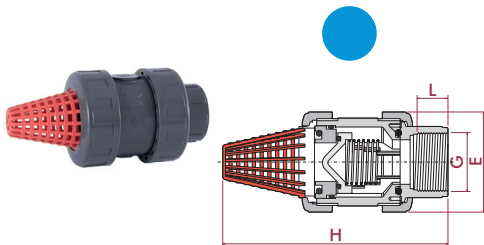

G	DN	PN	REF.	CODE.
3/8"	10	16	05 66 616	<b>09000</b>
1/2"	15	16	05 66 620	<b>09001</b>
3/4"	20	16	05 66 625	<b>09002</b>
1"	25	16	05 66 632	<b>09003</b>
1 1/4"	32	16	05 66 640	<b>09004</b>
1 1/2"	40	16	05 66 650	<b>09005</b>
2"	50	16	05 66 663	<b>09006</b>
2 1/2"	65	10	05 66 675	<b>09007</b>
3"	80	10	05 66 690	<b>09008</b>
4"	80	10	05 66 710	<b>09009</b>

L	H	E
14	107	52
16	107	52
19	130	62
22	154	70
26	176	84
31	202	94
38	239	117
44	306	148
51	362	179
61	367	179

**UP-S. 66. SF4 - SPRING FOOT CHECK VALVE**
**Foot valve**

- PVC-U body
- Female solvent socket
- Metric series
- O-Rings in FPM

**Válvula de pie**

- Cuerpo en PVC-U
- Encolar hembra
- Serie métrica
- Anillos tóricos en FPM

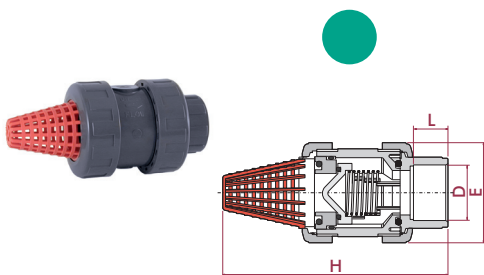

D	DN	PN	REF.	CODE
16	10	16	05 66 016 VI	<b>18731</b>
20	15	16	05 66 020 VI	<b>18732</b>
25	20	16	05 66 025 VI	<b>18733</b>
32	25	16	05 66 032 VI	<b>18734</b>
40	32	16	05 66 040 VI	<b>18735</b>
50	40	16	05 66 050 VI	<b>18736</b>
63	50	16	05 66 063 VI	<b>18737</b>
75	65	10	05 66 075 VI	<b>18738</b>
90	80	10	05 66 090 VI	<b>18739</b>
110	80	10	05 66 110 VI	<b>18740</b>

L	H	E
14	107	52
16	107	52
19	130	62
22	154	70
26	176	84
31	202	94
38	239	117
44	306	148
51	362	179
61	367	179

**UP-S. 66. FT4 - SPRING FOOT CHECK VALVE**
**Foot valve**

- PVC-U body
- BSP female thread
- O-Rings in FPM

**Válvula de pie**

- Cuerpo en PVC-U
- Roscar hembra BSP
- Anillos tóricos en FPM

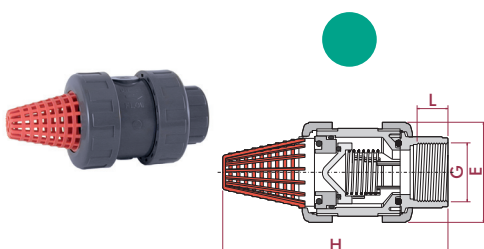

G	DN	PN	REF.	CODE
3/8"	10	16	05 66 616 VI	<b>18741</b>
1/2"	15	16	05 66 620 VI	<b>18742</b>
3/4"	20	16	05 66 625 VI	<b>18743</b>
1"	25	16	05 66 632 VI	<b>18744</b>
1 1/4"	32	16	05 66 640 VI	<b>18745</b>
1 1/2"	40	16	05 66 650 VI	<b>18746</b>
2"	50	16	05 66 663 VI	<b>18747</b>
2 1/2"	65	10	05 66 675 VI	<b>18748</b>
3"	80	10	05 66 690 VI	<b>18749</b>
4"	80	10	05 66 710 VI	<b>18750</b>

L	H	E
14	107	52
16	107	52
19	130	62
22	154	70
26	176	84
31	202	94
38	239	117
44	306	148
51	362	179
61	367	179

## PVC-U CHECK VALVES - UNIBLOCK SERIES

### VÁLVULAS ANTI-RETORNO PVC-U - SERIE UNIBLOCK



Sizes	Solvent cement D20 - D110 (DN15 - DN100) Threaded ½" - 4"	
Standards	Solvent socket - Metric Threaded - BSP	EN ISO 1452, EN ISO 15493 ISO 228-1
Working pressure	@ 20°C (73°F)  D20-D63 (½" - 2"): PN 16 (240 psi) D75 - D110 (2½" - 4"): PN 10 (150 psi)	
Minimum working pressure		
Materials	O-rings: EPDM	
Characteristics	<ul style="list-style-type: none"> <li>• <b>May be used either vertically and horizontally.</b></li> <li>• 100% factory tested.</li> <li>• Easy installation and maintenance.</li> <li>• Available in PVC-U.</li> <li>• Resistance to many inorganic chemicals.</li> <li>• Excellent flow characteristics.</li> </ul>	<ul style="list-style-type: none"> <li>• <b>Se pueden usar indistintamente verticalmente o horizontalmente.</b></li> <li>• Probadas al 100% en fábrica.</li> <li>• Fácil instalación y mantenimiento.</li> <li>• Disponibles en PVC-U.</li> <li>• Resistencia a múltiples sustancias químicas inorgánicas.</li> <li>• Excelentes características de conducción.</li> </ul>
Certifications / regulations	Check valve design regulation - ISO 16137:2006	

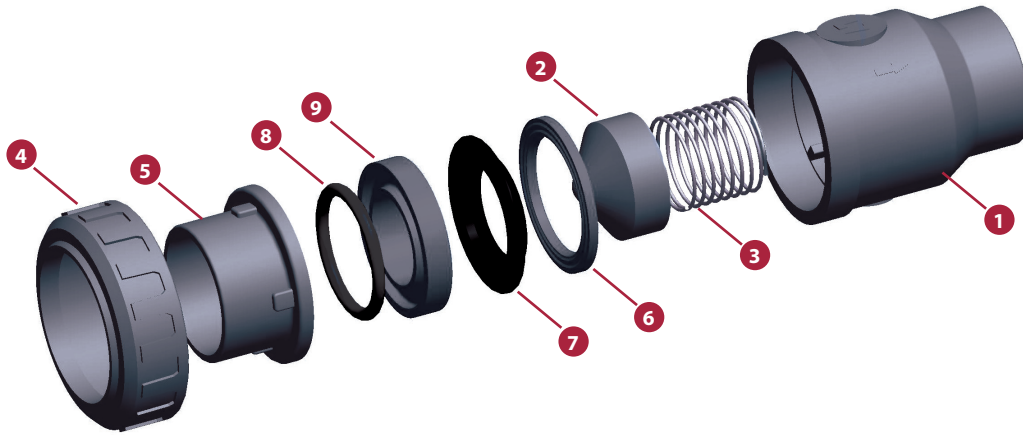
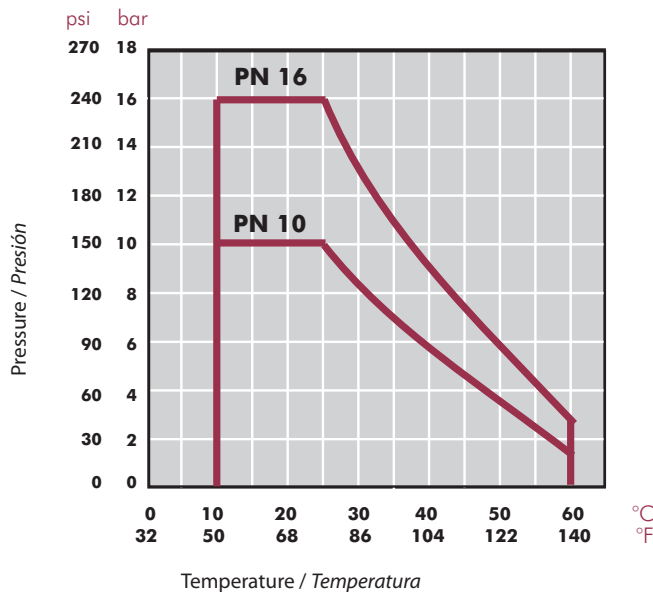

FIG.	Parts	Despiece	Material
1	Body	Cuerpo	PVC-U
2	Cone	Cono de cierre	PVC-U
3	Spring	Muelle	Stainless steel AISI 302
4	Union nut	Tuerca	PVC-U
5	End connector	Manguito enlace	PVC-U
6	Cone o-ring	Junta cono	EPDM
7	Body o-ring	Junta cuerpo	EPDM
8	End connector o-ring	Junta manguito	EPDM
9	Seal-carrier	Portajuntas	PVC-U

**PRESSURE / TEMPERATURE GRAPH**  
**DIAGRAMA PRESIÓN / TEMPERATURA**



Life: 25 years  
 Hydrostatic maximum pressure a component may withstand in continuous service (without overpressure)

Vida útil: 25 años  
 Presión hidrostática máxima que un componente es capaz de soportar en servicio continuo (sin sobrepresión)

**PRESSURE LOSS DIAGRAM**

**DIAGRAMA DE PÉRDIDAS DE CARGA**

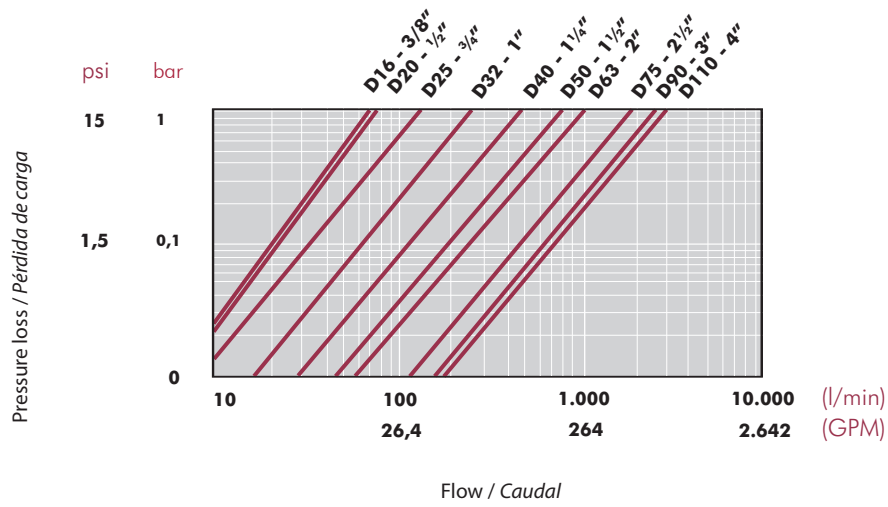

**RELATIVE FLOW**

**FLUJO RELATIVO**

D	20-1/2"	25-3/4"	32-1"	40-1 1/4"	50-1 1/2"	63-2"	75-2 1/2"	90-3"	110-4"
DN	15	20	25	32	40	50	65	80	100
$Kv_{100}$	68	133	208	383	667	850	1533	1160	1200
Cv	5	9	15	27	47	60	107	81,2	84

$Cv = Kv_{100} / 14,28$   
 $Kv_{100}$  (l/min,  $\Delta p = 1$  bar)  
 $Cv$  (GPM,  $\Delta p = 1$  psi)

Relative flow in fully open valve (maximum opening)  
 Flujo relativo en válvula completamente abierta (apertura máxima)

**OPENING PRESSURE**

**PRESIÓN DE APERTURA**

Minimum pressure: opening start  
 Maximum pressure: fully open valve

Presión mínima: inicio apertura  
 Presión máxima: válvula completamente abierta

D	P (bar) Minimum opening	P (bar) Maximum opening	P (psi) Minimum opening	P (psi) Maximum opening
20	0,11	0,19	1,57	2,71
25	0,035	0,067	0,5	0,95
32	0,042	0,077	0,6	1,1
40	0,038	0,069	0,54	0,98
50	0,063	0,088	0,9	1,25
63	0,038	0,060	0,54	0,85
75	0,031	0,060	0,44	0,85
90	0,025	0,060	0,35	0,85

**UP-B. 67. SF1 - UNIBLOCK CHECK VALVE**
**Uniblock check valve**

- PVC-U body
- Female solvent socket
- Metric series
- O-rings in EPDM

**Válvula anti-retorno Uniblock**

- Cuerpo en PVC-U
- Encolar hembra
- Serie métrica
- Anillos tóricos en EPDM

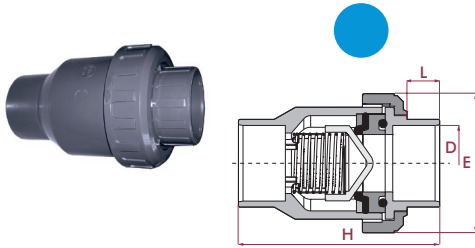

D	DN	PN	REF.	CODE
20	15	16	05 93 020	<b>36559</b>
25	20	16	05 93 025	<b>36560</b>
32	25	16	05 93 032	<b>36561</b>
40	32	16	05 93 040	<b>36562</b>
50	40	16	05 93 050	<b>36563</b>
63	50	16	05 93 063	<b>36564</b>
75	65	10	05 93 075	<b>36565</b>
90	80	10	05 93 090	<b>36566</b>
110	80	10	05 93 111	<b>36567</b>

L	H	E
16	81	52
19	103	60
22	117	69
26	135	84
31	135	94
38	169	116
44	220	128
51	256	178
63	331	228

**UP-B. 67. FT1 - UNIBLOCK CHECK VALVE**
**Uniblock check valve**

- PVC-U body
- BSP female thread
- O-Rings in EPDM

**Válvula anti-retorno Uniblock**

- Cuerpo en PVC-U
- Roscar hembra BSP
- Anillos tóricos en EPDM

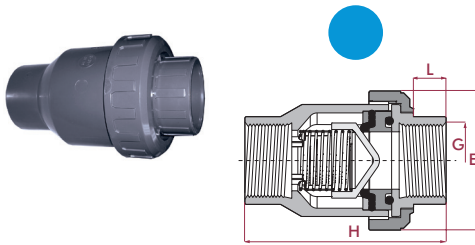

G	DN	PN	REF.	CODE
½"	15	16	05 93 620	<b>36568</b>
¾"	20	16	05 93 625	<b>36569</b>
1"	25	16	05 93 632	<b>36570</b>
1¼"	32	16	05 93 640	<b>36571</b>
1½"	40	16	05 93 650	<b>36572</b>
2"	50	16	05 93 663	<b>36573</b>
2½"	65	10	05 93 675	<b>36574</b>
3"	80	10	05 93 690	<b>36575</b>
4"	80	10	05 93 711	<b>36576</b>

L	H	E
16	85	52
19	103	60
19	117	69
23	135	84
31	135	94
34	169	116
44	220	128
51	256	178
63	331	228



## PVC-U CHECK VALVES - BALL SERIES

### VÁLVULAS ANTI-RETORNO PVC-U - SERIE BOLA



Sizes	Solvent cement D20 - D110 (DN15 - DN100) Threaded 1/2" - 4"	
Standards	Solvent socket - Metric, British standard, ASTM, JIS Threaded - BSP, NPT	EN ISO 1452, EN ISO 15493, BS 4346-1, ASTM D 2467, JIS K 6743 ISO 228-1, ASTM D 2464
Working pressure	@ 20°C (73°F)  D20-D63 (1/2" - 2"): PN 16 (240 psi) D75 - D110 (2 1/2" - 4"): PN 10 (150 psi)	
Minimum return pressure	<b>0,2 bar (3 psi)</b> <b>Minimal downstream pressure to keep the valve closed in horizontal position.</b> <b>Presión mínima aguas abajo para mantener la válvula cerrada en caso de instalación horizontal.</b>	
Materials	O-rings: EPDM / FPM	
Characteristics	<ul style="list-style-type: none"> <li>• <b>Completely made in plastic - corrosion free.</b></li> <li>• 100% factory tested.</li> <li>• Excellent flow rate.</li> <li>• Easy installation and maintenance.</li> <li>• May be used either vertically and horizontally.</li> <li>• Available in PVC-U and Corzan® PVC-C.</li> <li>• Resistance to many inorganic chemicals.</li> <li>• Excellent flow characteristics.</li> </ul>	<ul style="list-style-type: none"> <li>• <b>Fabricada completamente en plástico - libre de corrosión.</b></li> <li>• Probadas al 100% en fábrica.</li> <li>• Excelente coeficiente de caudal.</li> <li>• Fácil instalación y mantenimiento.</li> <li>• Se pueden usar indistintamente verticalmente o horizontalmente.</li> <li>• Disponibles en PVC-U y Corzan® PVC-C.</li> <li>• Resistencia a múltiples sustancias químicas inorgánicas.</li> <li>• Excelentes características de conducción.</li> </ul>
Certifications / regulations	Check valve design regulation - ISO 16137:2006	

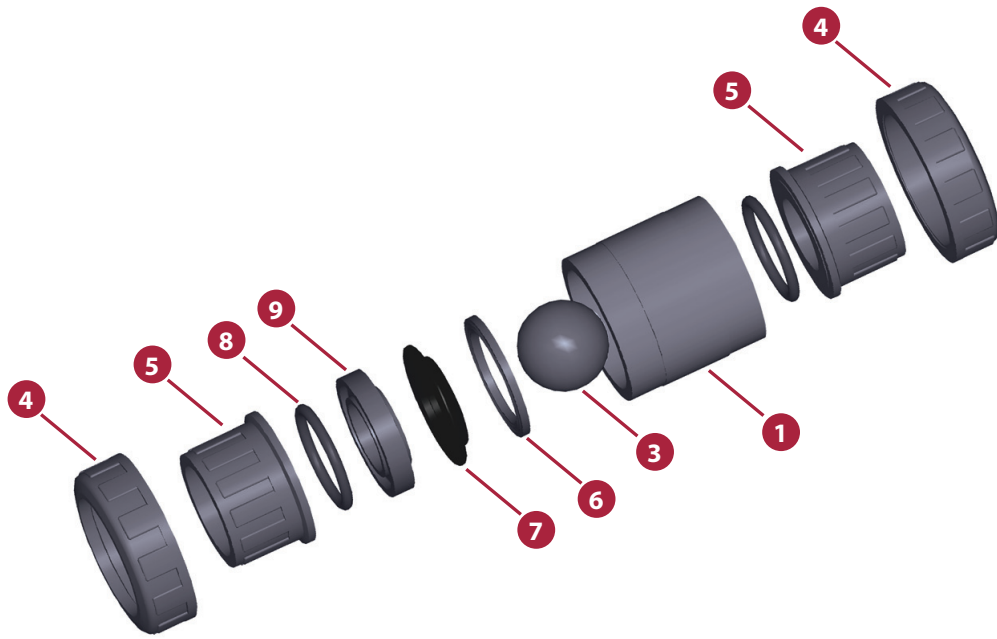
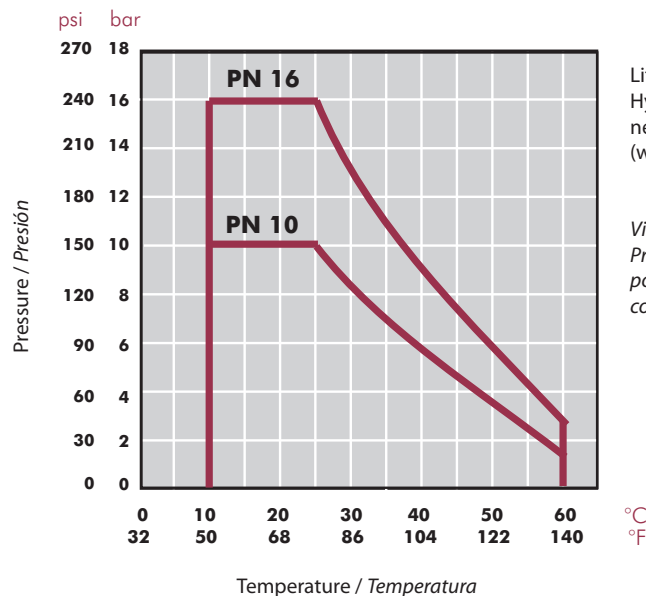

FIG.	Parts	Despiece	Material
1	Body	Cuerpo	PVC-U
3	Ball	Bola	PVC-U
4	Union nut	Tuerca	PVC-U
5	End connector	Manguito enlace	PVC-U
6	Closing ring	Anillo de cierre	PVC-U
7	Body o-ring	Junta cuerpo	EPDM / FPM
8	End connector o-ring	Junta manguito	EPDM / FPM
9	Seal-carrier	Portajuntas	PVC-U

**PRESSURE / TEMPERATURE GRAPH**  
**DIAGRAMA PRESIÓN / TEMPERATURA**



Life: 25 years  
Hydrostatic maximum pressure a component may withstand in continuous service (without overpressure)

Vida útil: 25 años  
Presión hidrostática máxima que un componente es capaz de soportar en servicio continuo (sin sobrepresión)

**PRESSURE LOSS DIAGRAM**  
**DIAGRAMA DE PÉRDIDAS DE CARGA**

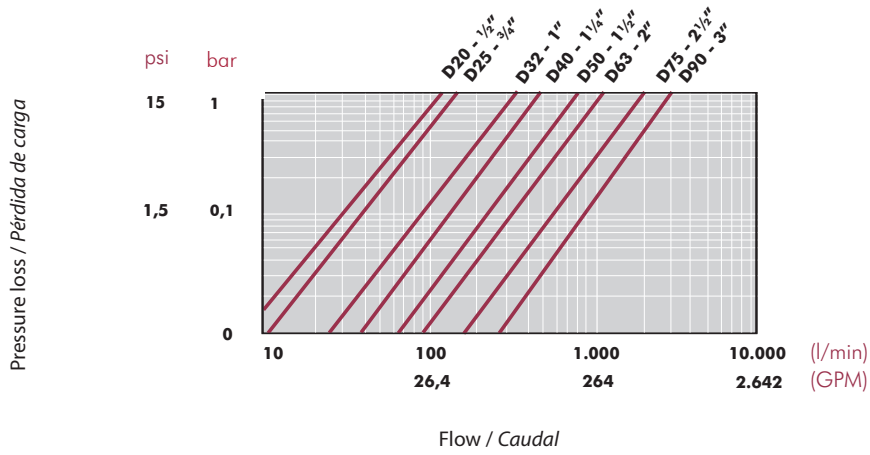

**RELATIVE FLOW**  
**FLUJO RELATIVO**

D	20-1/2"	25-3/4"	32-1"	40-1 1/4"	50-1 1/2"	63-2"	75-2 1/2"	90-3"
DN	15	20	25	32	40	50	65	80
Kv <sub>100</sub>	99	128	308	453	795	1040	1932	2754
Cv	7	9	22	32	56	73	135	193

$Cv = Kv_{100} / 14,28$   
 $Kv_{100}$  (l/min,  $\Delta p = 1$  bar)  
 $Cv$  (GPM,  $\Delta p = 1$  psi)

**Open**  
**Abierto**

**Closed**  
**Cerrado**

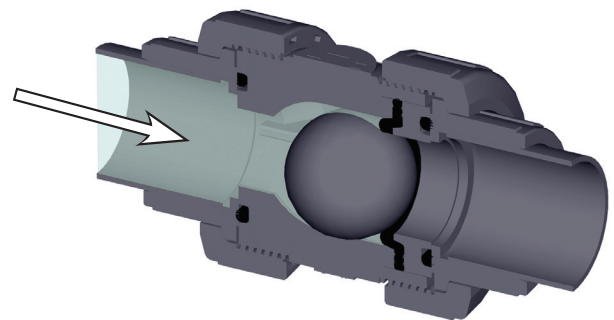
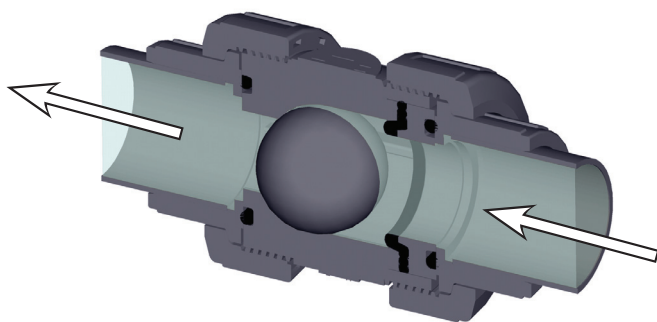

### ASSEMBLY INSTRUCTIONS

#### Solvent socket or threaded unions

Loosen the valve union nuts (4) and separate these and the end connectors (5) from the valve body. Pass the pipe through the nuts and then place the bushes over the end of the pipe. The socket unions should be glued onto the pipe using a PVC-U or PVC-C adhesive and pressure should not be applied to the system until a drying period of at least 1 hour per bar of working pressure has elapsed. In the case of threaded unions, PTFE tape should be applied to the male threads. The pipes can now be attached to the valve by hand tightening down the nuts.

### INSTRUCCIONES DE MONTAJE

#### Uniones encoladas o roscadas

Afloje las tuercas (4) de la válvula y sepárelas de los manguitos (5). Introduzca las tuercas en los tubos y a continuación fije los manguitos en los extremos del tubo. Las uniones encoladas se realizarán con un adhesivo para tubos de PVC-U o PVC-C rígido y no se aplicará presión hasta transcurridas al menos 1 hora por bar. En las uniones roscadas se colocará cinta de PTFE en las roscas macho. A continuación ya podrá colocarse la válvula entre los manguitos y apretar a mano las tuercas sobre la válvula.

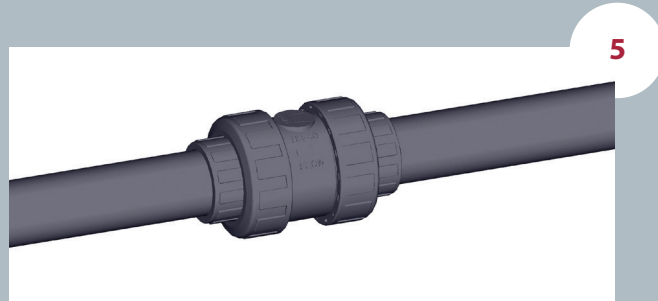
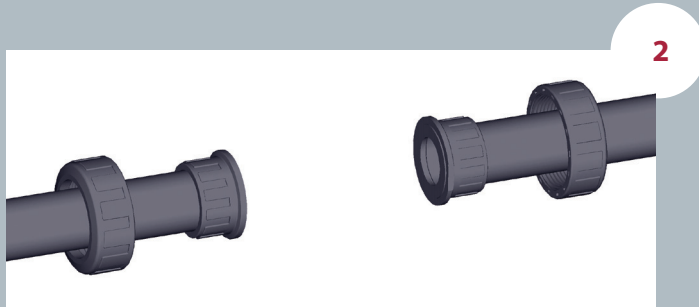
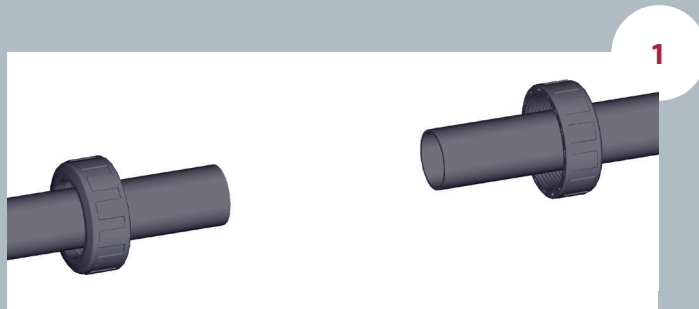

### UP-B. 67. SF1 - BALL CHECK VALVE

**Ball check valve**

- PVC-U body
- Female solvent socket
- Metric series
- O-rings in EPDM

**Válvula anti-retorno de bola**

- Cuerpo en PVC-U
- Encolar hembra
- Serie métrica
- Anillos tóricos en EPDM

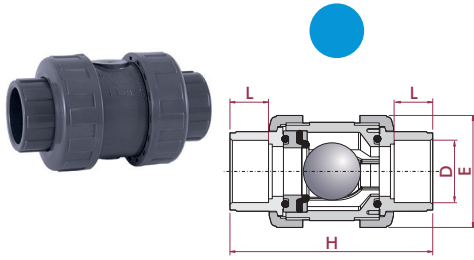

D	DN	PN	REF.	CODE
20	15	16	05 67 220	<b>22078</b>
25	20	16	05 67 225	<b>22079</b>
32	25	16	05 67 232	<b>22080</b>
40	32	16	05 67 240	<b>22174</b>
50	40	16	05 67 250	<b>25697</b>
63	50	16	05 67 263	<b>25698</b>
75	65	10	05 67 275	<b>22175</b>
90	80	10	05 67 290	<b>22176</b>
110	80	10	05 67 310	<b>22177</b>

L	H	E
16	84	52
19	108	62
22	119	70
26	142	84
31	162	94
38	192	117
44	232	148
51	269	179
51	269	179

### UP-B. 67. FT1 - BALL CHECK VALVE

**Ball check valve**

- PVC-U body
- BSP female thread
- O-Rings in EPDM

**Válvula anti-retorno de bola**

- Cuerpo en PVC-U
- Roscar hembra BSP
- Anillos tóricos en EPDM

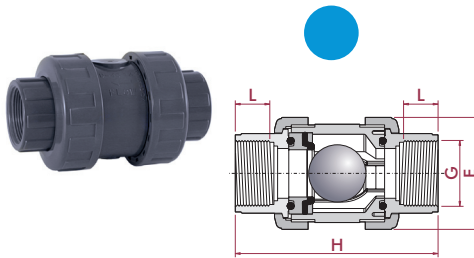

G	DN	PN	REF.	CODE
½"	15	16	05 67 420	<b>22061</b>
¾"	20	16	05 67 425	<b>22062</b>
1"	25	16	05 67 432	<b>22085</b>
1¼"	32	16	05 67 440	<b>22086</b>
1½"	40	16	05 67 450	<b>25699</b>
2"	50	16	05 67 463	<b>25700</b>
2½"	65	10	05 67 475	<b>22087</b>
3"	80	10	05 67 490	<b>22088</b>
4"	80	10	05 67 510	<b>22089</b>

L	H	E
16	84	52
19	108	62
22	119	70
26	142	84
31	167	94
38	192	117
44	232	148
51	269	179
61	279	179

### UP-B. 67. SF4 - BALL CHECK VALVE

**Ball check valve**

- PVC-U body
- Female solvent socket
- Metric series
- O-Rings in FPM

**Válvula anti-retorno de bola**

- Cuerpo en PVC-U
- Encolar hembra
- Serie métrica
- Anillos tóricos en FPM

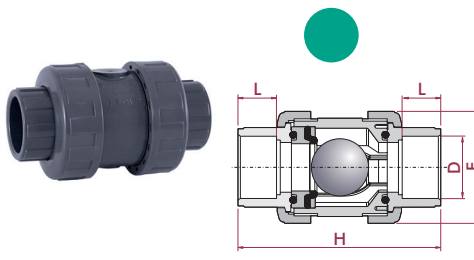

D	DN	PN	REF.	CODE
20	15	16	05 67 220 VI	<b>22090</b>
25	20	16	05 67 225 VI	<b>22091</b>
32	25	16	05 67 232 VI	<b>22092</b>
40	32	16	05 67 240 VI	<b>22239</b>
50	40	16	05 67 250 VI	<b>25701</b>
63	50	16	05 67 263 VI	<b>25702</b>
75	65	10	05 67 275 VI	<b>22240</b>
90	80	10	05 67 290 VI	<b>22241</b>
110	80	10	05 67 310 VI	<b>22242</b>

L	H	E
16	84	52
19	108	62
22	119	70
26	142	84
31	162	94
38	192	117
44	232	148
51	269	179
51	269	179

### UP-B. 67. FT4 - BALL CHECK VALVE

**Ball check valve**

- PVC-U body
- BSP female thread
- O-Rings in FPM

**Válvula anti-retorno de bola**

- Cuerpo en PVC-U
- Roscar hembra BSP
- Anillos tóricos en FPM

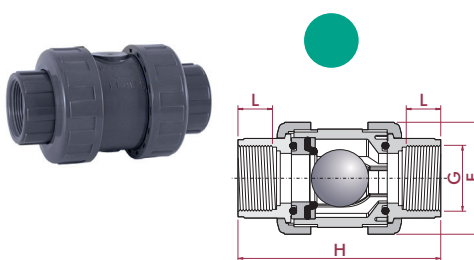

G	DN	PN	REF.	CODE
½"	15	16	05 67 420 VI	<b>22243</b>
¾"	20	16	05 67 425 VI	<b>22244</b>
1"	25	16	05 67 432 VI	<b>22267</b>
1¼"	32	16	05 67 440 VI	<b>22268</b>
1½"	40	16	05 67 450 VI	<b>25703</b>
2"	50	16	05 67 463 VI	<b>25704</b>
2½"	65	10	05 67 475 VI	<b>22269</b>
3"	80	10	05 67 490 VI	<b>22270</b>
4"	80	10	05 67 510 VI	<b>22893</b>

L	H	E
16	84	52
19	108	62
22	119	70
26	142	84
31	167	94
38	192	117
44	232	148
51	269	179
61	279	179

## PVC-U FOOT VALVES - BALL SERIES

### VÁLVULAS DE PIE PVC-U - SERIE BOLA



Sizes	Solvent cement D20 - D110 (DN15 - DN100) Threaded ½" - 4"	
Standards	Solvent socket - Metric, British standard, ASTM, JIS Threaded - BSP, NPT	EN ISO 1452, EN ISO 15493, BS 4346-1, ASTM D 2467, JIS K 6743 ISO 228-1, ASTM D 2464
Working pressure	@ 20°C (73°F)  D20-D63 (¾" - 2"): PN 16 (240 psi) D75 - D110 (2½" - 4"): PN 10 (150 psi)	
Minimum return pressure	<b>0,2 bar (3 psi)</b> <b>Minimal downstream pressure to keep the valve closed in horizontal position.</b> <b>Presión mínima aguas abajo para mantener la válvula cerrada en caso de instalación horizontal.</b>	
Materials	O-rings: EPDM / FPM	
Characteristics	<ul style="list-style-type: none"> <li>• <b>Completely made in plastic - corrosion free.</b></li> <li>• 100% factory tested.</li> <li>• Easy installation and maintenance.</li> <li>• May be used either vertically and horizontally.</li> <li>• Available in PVC-U.</li> <li>• Resistance to many inorganic chemicals.</li> <li>• Excellent flow characteristics.</li> </ul>	<ul style="list-style-type: none"> <li>• <b>Fabricada completamente en plástico - libre de corrosión</b></li> <li>• Probadas al 100% en fábrica.</li> <li>• Fácil instalación y mantenimiento.</li> <li>• Se pueden usar indistintamente verticalmente o horizontalmente.</li> <li>• Disponibles en PVC-U.</li> <li>• Resistencia a múltiples sustancias químicas inorgánicas.</li> <li>• Excelentes características de conducción.</li> </ul>
Certifications / regulations	Check valve design regulation - ISO 16137:2006	

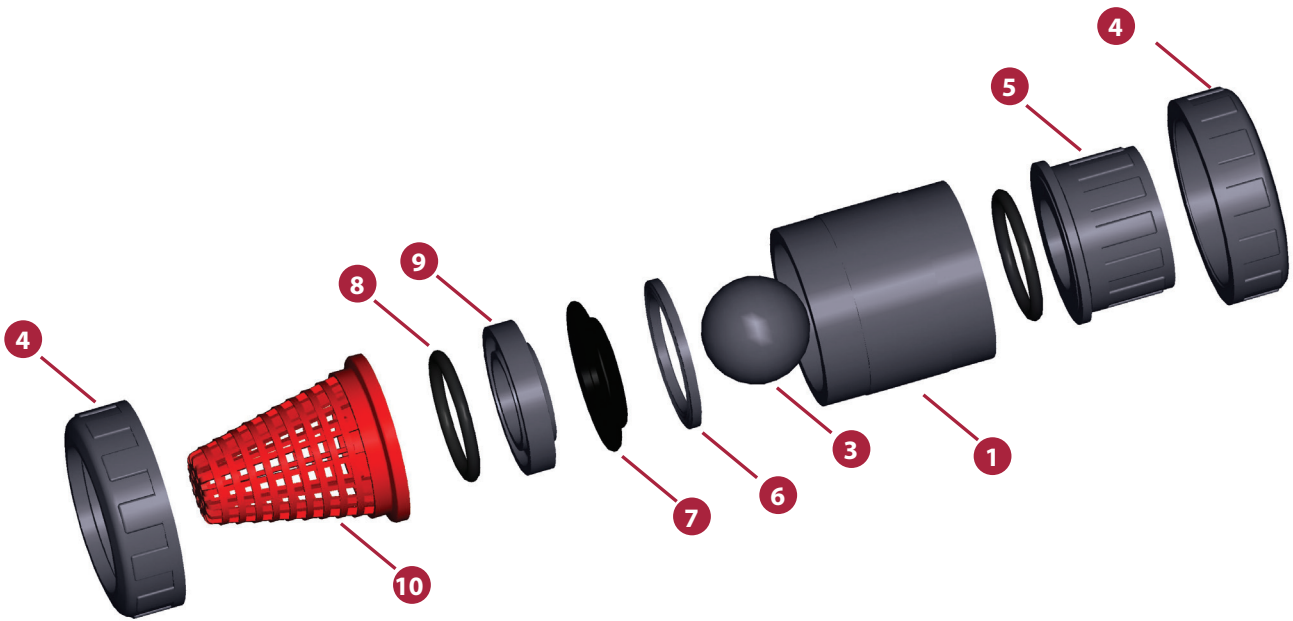
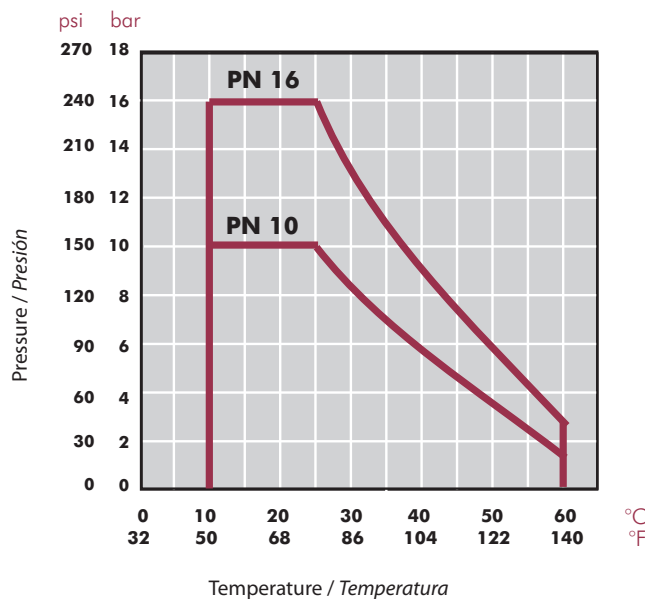

FIG.	Parts	Despiece	Material
1	Body	Cuerpo	PVC-U
3	Ball	Bola	PVC-U
4	Union nut	Tuerca	PVC-U
5	End connector	Manguito enlace	PVC-U
6	Closing ring	Anillo de cierre	PVC-U
7	Body o-ring	Junta cuerpo	EPDM / FPM
8	End connector o-ring	Junta manguito	EPDM / FPM
9	Seal-carrier	Portajuntas	PVC-U
10	Foot valve screen	Rejilla	PP

**PRESSURE / TEMPERATURE GRAPH**  
**DIAGRAMA PRESIÓN / TEMPERATURA**



Life: 25 years  
 Hydrostatic maximum pressure a component may withstand in continuous service (without overpressure)

Vida útil: 25 años  
 Presión hidrostática máxima que un componente es capaz de soportar en servicio continuo (sin sobrepresión)

**PRESSURE LOSS DIAGRAM**  
**DIAGRAMA DE PÉRDIDAS DE CARGA**

D20 - 1/2"		D25 - 3/4"		D32 - 1"		D40 - 1 1/4"		D50 - 1 1/2"		D63 - 2"		D75 - 2 1/2"		D90 - 3"	
A	B	A	B	A	B	A	B	A	B	A	B	A	B	A	B
1,65	0,13	1,47	0,05	4,36	0,08	4,87	0,15	6,41	0,002	12,53	0,05	12,32	0,05	7,13	0,009
2,33	0,24	2,01	0,054	4,89	0,11	6,21	0,17	11,3	0,02	14,9	0,07	14,95	0,06	15,91	0,04
3,34	0,44	2,34	0,09	5,44	0,15	7,52	0,21	18,76	0,16	17,12	0,11	19,53	0,11	28,58	0,13
3,85	0,52	2,95	0,18	5,89	0,21	10,61	0,27	25,05	0,34	21,7	0,16	25	0,17	37,22	0,22
4,52	0,69	3,6	0,29	7,01	0,26	12,53	0,34	28,44	0,41	27,36	0,28	32,6	0,28	45,61	0,53
-	-	4,03	0,36	9,23	0,39	15,23	0,4	-	-	32,02	0,37	41,43	0,55	58,5	0,64
-	-	4,21	0,38	-	-	-	-	-	-	37,68	0,43	-	-	-	-

**A =** Flow (m<sup>3</sup>/h)  
Caudal (m<sup>3</sup>/h)

**B =** Pressure loss (bar)  
Pérdida de carga (bar)

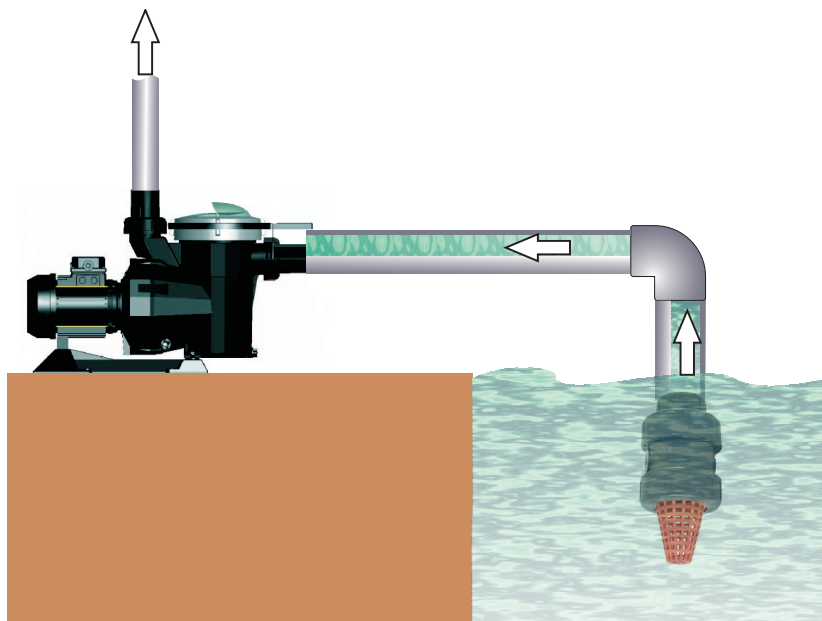



### UP-B. 66. SF1 - BALL FOOT CHECK VALVES

**Ball foot valve**

- PVC-U body
- Female solvent socket
- Metric series
- O-Rings in EPDM

**Válvula de pie de bola**

- Cuerpo en PVC-U
- Encolar hembra
- Serie métrica
- Anillos tóricos en EPDM

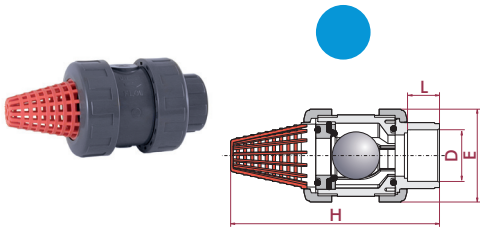

D	DN	PN	REF.	CODE
20	15	16	05 66 220	<b>27537</b>
25	20	16	05 66 225	<b>27538</b>
32	25	16	05 66 232	<b>27539</b>
40	32	16	05 66 240	<b>27540</b>
50	40	16	05 66 250	<b>25705</b>
63	50	16	05 66 263	<b>25706</b>
75	65	10	05 66 275	<b>27543</b>
90	80	10	05 66 290	<b>27544</b>
110	80	10	05 66 310	<b>27545</b>

L	H	E
16	107	52
19	130	62
22	154	70
26	176	84
31	202	94
38	239	117
44	306	148
51	362	179
61	367	179

### UP-B. 66. FT1 - BALL FOOT CHECK VALVES

**Ball foot valve**

- PVC-U body
- BSP female thread
- O-Rings in EPDM

**Válvula de pie de bola**

- Cuerpo en PVC-U
- Roscar hembra BSP
- Anillos tóricos en EPDM

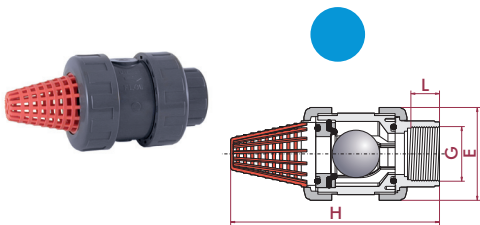

G	DN	PN	REF.	CODE
½"	15	16	05 66 420	<b>27546</b>
¾"	20	16	05 66 425	<b>27547</b>
1"	25	16	05 66 432	<b>27548</b>
1¼"	32	16	05 66 440	<b>27549</b>
1½"	40	16	05 66 450	<b>25707</b>
2"	50	16	05 66 463	<b>25708</b>
2½"	65	10	05 66 475	<b>27552</b>
3"	80	10	05 66 490	<b>27553</b>
4"	80	10	05 66 510	<b>27554</b>

L	H	E
16	107	52
19	130	62
22	154	70
26	176	84
31	202	94
38	239	117
44	306	148
51	362	179
61	367	179

### UP-B. 66. SF4 - BALL FOOT CHECK VALVES

**Ball foot valve**

- PVC-U body
- Female solvent socket
- Metric series
- O-Rings in FPM

**Válvula de pie de bola**

- Cuerpo en PVC-U
- Encolar hembra
- Serie métrica
- Anillos tóricos en FPM

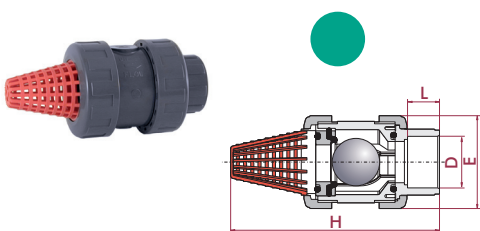

D	DN	PN	REF.	CODE
20	15	16	05 66 220 VI	<b>27555</b>
25	20	16	05 66 225 VI	<b>27556</b>
32	25	16	05 66 232 VI	<b>27557</b>
40	32	16	05 66 240 VI	<b>27558</b>
50	40	16	05 66 250 VI	<b>25709</b>
63	50	16	05 66 263 VI	<b>25710</b>
75	65	10	05 66 275 VI	<b>27561</b>
90	80	10	05 66 290 VI	<b>27562</b>
110	80	10	05 66 310 VI	<b>27563</b>

L	H	E
16	107	52
19	130	62
22	154	70
26	176	84
31	202	94
38	239	117
44	306	148
51	362	179
61	367	179

### UP-B. 66. FT4 - BALL FOOT CHECK VALVES

**Ball foot valve**

- PVC-U body
- BSP female thread
- O-Rings in FPM

**Válvula de pie de bola**

- Cuerpo en PVC-U
- Roscar hembra BSP
- Anillos tóricos en FPM

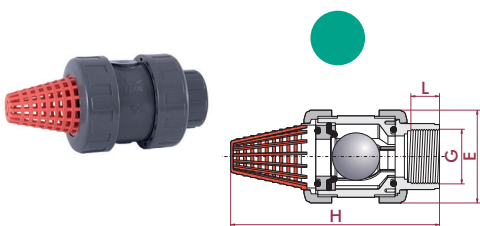

G	DN	PN	REF.	CODE
½"	15	16	05 66 420 VI	<b>27564</b>
¾"	20	16	05 66 425 VI	<b>27565</b>
1"	25	16	05 66 432 VI	<b>27566</b>
1¼"	32	16	05 66 440 VI	<b>27567</b>
1½"	40	16	05 66 450 VI	<b>25711</b>
2"	50	16	05 66 463 VI	<b>25712</b>
2½"	65	10	05 66 475 VI	<b>27570</b>
3"	80	10	05 66 490 VI	<b>27571</b>
4"	80	10	05 66 510 VI	<b>27572</b>

L	H	E
16	107	52
19	130	62
22	154	70
26	176	84
31	202	94
38	239	117
44	306	148
51	362	179
61	367	179

## PVC-U SWING CHECK VALVES

### VÁLVULAS DE CLAPETA PVC-U



Sizes	Metric flanges D63 - D315 (DN50 - DN300) ASTM flanges 4" - 12"	
Standards	ISO/DIN ASTM - 4" - 12"	EN 558-1 ANSI B.16.5 cl. 150
Working pressure	@ 20°C (73°F)  D63 - D315 (2" - 12"): PN 6 (90 psi)	
Minimum return pressure	<b>0,1 - 0,3 bar</b> <b>Minimal downstream pressure to keep the valve closed, depending on installation conditions.</b> <b>Presión mínima aguas abajo para mantener la válvula cerrada, dependiendo de las condiciones de instalación.</b>	
Materials	O-rings: EPDM / FPM	
Characteristics	<ul style="list-style-type: none"> <li>• Requires little space in piping systems.</li> <li>• Easy installation: wafer body slips between standard flanges. <b>No gaskets required.</b></li> <li>• Vertical and horizontal operation.</li> <li>• Excellent flow characteristics.</li> </ul> <p>Do not install the valve at a distance lower than 5 x D of the pump out. Install with pipe DIN PN 10. In case of PN 16, the valve could be damaged.</p>	<ul style="list-style-type: none"> <li>• Requiere poco espacio en la instalación.</li> <li>• Fácil instalación: se monta entre bridas standard. <b>Sin necesidad de juntas adicionales.</b></li> <li>• Instalación vertical y horizontal.</li> <li>• Excelentes características de conducción.</li> </ul> <p>No montar la válvula a una distancia inferior a 5 x D de la salida de una bomba. Montar con tubo PN 10. En caso de usar un PN 16 se podrían ocasionar daños en la válvula.</p>
Certifications / regulations	Check valve design regulation - ISO 16137:2006	

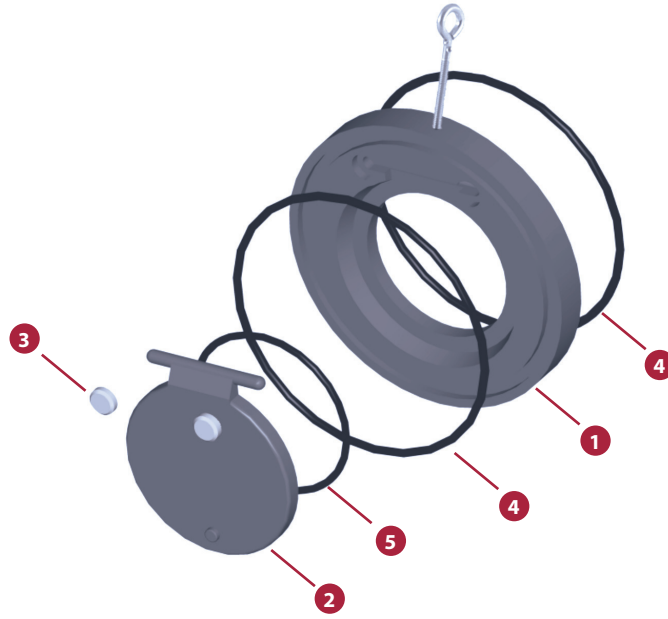
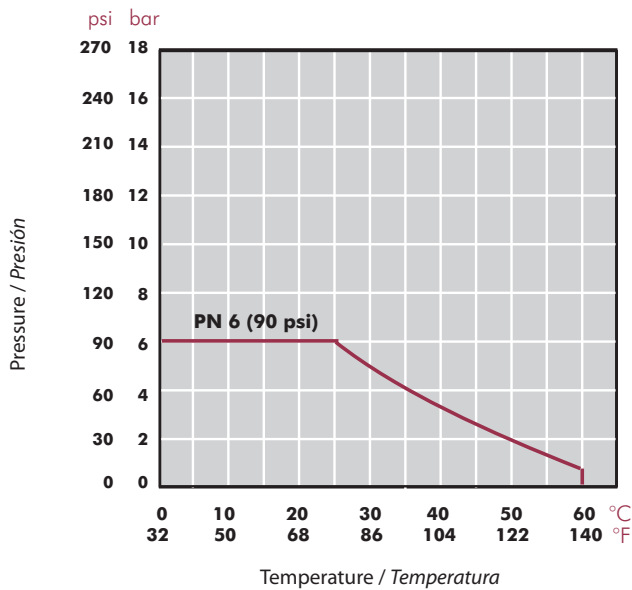

FIG.	Parts	Despiece	Material
1	Body	Cuerpo	PVC-U
2	Flap	Clapeta	PVC-U
3	Cap	Tapón	PP
4	Body O-ring	Junta cuerpo	EPDM / FPM
5	Flap O-ring	Junta clapeta	EPDM / FPM

**PRESSURE / TEMPERATURE GRAPH**  
**DIAGRAMA PRESIÓN / TEMPERATURA**



Life: 25 years  
 Hydrostatic maximum pressure a component may withstand in continuous service (without overpressure)

*Vida útil: 25 años*  
*Presión hidrostática máxima que un componente es capaz de soportar en servicio continuo (sin sobrepresión)*

PRESSURE LOSS DIAGRAM

DIAGRAMA DE PÉRDIDAS DE CARGA

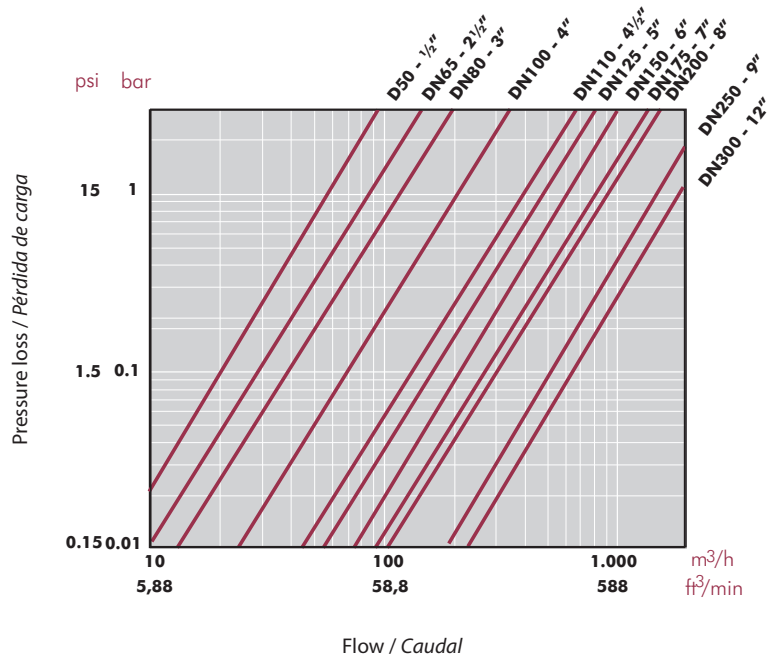

RELATIVE FLOW

FLUJO RELATIVO

D	63	75	90	110	125	140	160	200	225	250	280	315
DN	50	65	80	100	125	125	150	175	200	250	250	300
Kv <sub>100</sub>	57	85	130	200	390	480	600	800	900	1.600	1.600	1.850
Cv	4,0	6,0	9,1	14,0	27,3	33,6	42,0	56,0	63,0	112,0	112,0	129,6

Cv = Kv<sub>100</sub> / 14,28  
 Kv<sub>100</sub> (l/min, Δp = 1 bar)  
 Cv (GPM, Δp = 1 psi)

### UP. 65 - SWING CHECK VALVE

**Swing check valve**

- PVC-U body
- O-rings in EPDM

**Válvula de clapeta**

- Cuerpo en PVC-U
- Anillos tóricos en EPDM

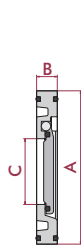
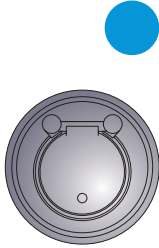

D	DN	PN	REF.	CODE
63	50	6	05 65 063 *	<b>37055</b>
75	65	6	05 65 075	<b>08984</b>
90	80	6	05 65 090	<b>08985</b>
110	100	6	05 65 110	<b>08986</b>
125	125	6	05 65 125	<b>09040</b>
140	125	6	05 65 140	<b>08987</b>
160	150	6	05 65 160	<b>08988</b>
200	175	6	05 65 200	<b>09041</b>
225	200	6	05 65 225	<b>08989</b>
250	250	6	05 65 250	<b>37056</b>
280	250	6	05 65 280 *	<b>41865</b>
315	300	6	05 65 315 *	<b>37057</b>

A	B	C
109	20	32
129	20	40
144	20	52
164	22	70
170	25	83
195	23	92
220	25	112
247	28	139
275	35	150
328	40	162
330	40	189
380	45	226

### UP. 65. FG - SWING CHECK VALVE

**Swing check valve**

- PVC-U body
- O-rings in EPDM perox.

**Válvula de clapeta**

- Cuerpo en PVC-U
- Anillos tóricos en EPDM perox.

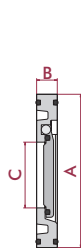
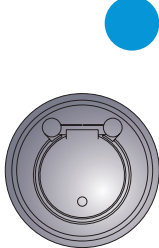

D	DN	PN	REF.	CODE
63	50	6	05 65 063 FG *	<b>37055FG</b>
75	65	6	05 65 075 FG	<b>08984FG</b>
90	80	6	05 65 090 FG	<b>08985FG</b>
110	100	6	05 65 110 FG	<b>08986FG</b>
125	125	6	05 65 125 FG	<b>09040FG</b>
140	125	6	05 65 140 FG	<b>08987FG</b>
160	150	6	05 65 160 FG	<b>08988FG</b>
200	175	6	05 65 200 FG	<b>09041FG</b>
225	200	6	05 65 225 FG	<b>08989FG</b>
250	250	6	05 65 250 FG	<b>37056FG</b>
280	250	6	05 65 280 FG*	<b>41865FG</b>
315	300	6	05 65 315 FG*	<b>37057FG</b>

A	B	C
109	20	32
129	20	40
144	20	52
164	22	70
170	25	83
195	23	92
220	25	112
247	28	139
275	35	150
328	40	162
330	40	189
380	45	226

### UP. 65. VIT - SWING CHECK VALVE

**Swing check valve**

- PVC-U body
- O-rings in FPM

**Válvula de clapeta**

- Cuerpo en PVC-U
- Anillos tóricos en FPM

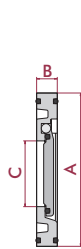
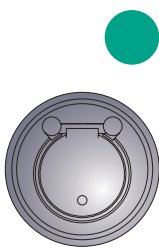

D	DN	PN	REF.	CODE
63	50	6	05 65 063 VIT*	<b>37055VI</b>
75	65	6	05 65 075 VIT	<b>08984VI</b>
90	80	6	05 65 090 VIT	<b>08985VI</b>
110	100	6	05 65 110 VIT	<b>08986VI</b>
125	125	6	05 65 125 VIT	<b>09040VI</b>
140	125	6	05 65 140 VIT	<b>08987VI</b>
160	150	6	05 65 160 VIT	<b>08988VI</b>
200	175	6	05 65 200 VIT	<b>09041VI</b>
225	200	6	05 65 225 VIT	<b>08989VI</b>
250	250	6	05 65 250 VIT	<b>37056VI</b>
280	250	6	05 65 280 VIT*	<b>41865VI</b>
315	300	6	05 65 315 VIT*	<b>37057VI</b>

A	B	C
109	20	32
129	20	40
144	20	52
164	22	70
170	25	83
195	23	92
220	25	112
247	28	139
275	35	150
328	40	162
330	40	189
380	45	226

### UP. 65. VKIT - SWING CHECK VALVE KIT

**Swing check valve with mounting kit**

- PVC-U body
- O-rings in EPDM
- Loose flanges

**Válvula de clapeta con kit accesorios**

- Cuerpo en PVC-U
- Anillos tóricos en EPDM
- Bridas locas

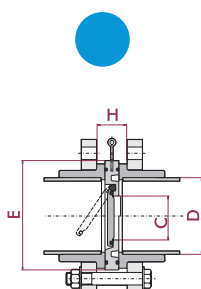

D	DN	PN	REF.	CODE
63	50	6	05 65 063 RA *	<b>37073</b>
75	65	6	05 65 075 RA	<b>23312</b>
90	80	6	05 65 090 RA	<b>23313</b>
110	100	6	05 65 110 RA	<b>23314</b>
125	125	6	05 65 125 RA	<b>23315</b>
140	125	6	05 65 140 RA	<b>23316</b>
160	150	6	05 65 160 RA	<b>23317</b>
200	175	6	05 65 200 RA	<b>23318</b>
225	200	6	05 65 225 RA	<b>23319</b>
250	250	6	05 65 250 RA	<b>37074</b>
315	300	6	05 65 315 RA *	<b>37075</b>

C	H	E
32	26	109
40	30	129
52	30	144
70	32	164
83	35	170
92	33	195
112	37	220
139	40	247
150	51	275
162	56	328
226	64	330

## PVC-U CHECK VALVES - SPRING SERIES

### VÁLVULAS ANTI-RETORNO PVC-U - SERIE MUELLE



Sizes	Solvent cement D16 - D110 (DN10 - DN100) Threaded 3/8" - 4"	
Standards	Solvent socket - Metric, British standard, ASTM, JIS Threaded - BSP, NPT	EN ISO 1452, EN ISO 15493, BS 4346-1, ASTM D 2467, JIS K 6743 ISO 228-1, ASTM D 2464
Working pressure	@ 20°C (73°F)  D16-D63 (3/8" - 2"): PN 16 (240 psi) D75 - D110 (2 1/2" - 4"): PN 10 (150 psi)	
Minimum working pressure		
Materials	O-rings: EPDM / FPM	
Characteristics	<ul style="list-style-type: none"> <li>• <b>May be used either vertically and horizontally.</b></li> <li>• 100% factory tested.</li> <li>• Easy installation and maintenance.</li> <li>• Available in PVC-U and Corzan® PVC-C.</li> <li>• Resistance to many inorganic chemicals.</li> <li>• Excellent flow characteristics.</li> </ul>	<ul style="list-style-type: none"> <li>• <b>Se pueden usar indistintamente verticalmente o horizontalmente.</b></li> <li>• Probadas al 100% en fábrica.</li> <li>• Fácil instalación y mantenimiento.</li> <li>• Disponibles en PVC-U y Corzan® PVC-C.</li> <li>• Resistencia a múltiples sustancias químicas inorgánicas.</li> <li>• Excelentes características de conducción.</li> </ul>
Certifications / regulations	Check valve design regulation - ISO 16137:2006	

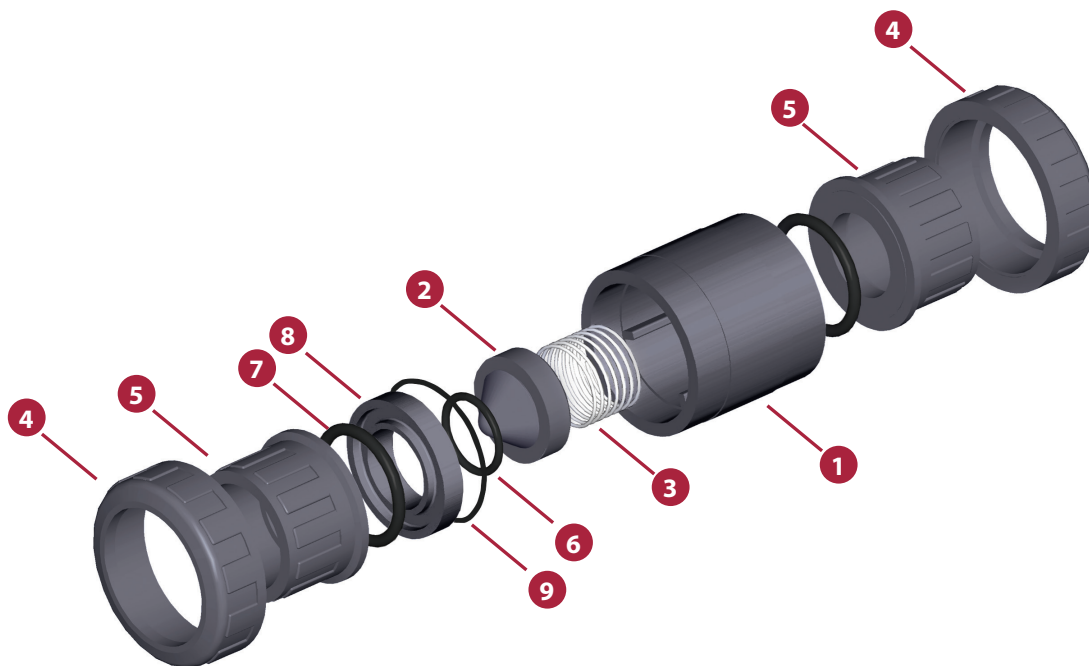
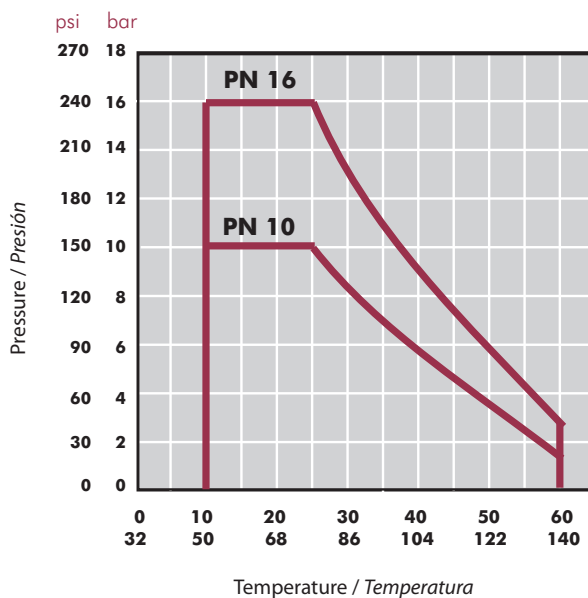

FIG.	Parts	Despiece	Material
1	Body	Cuerpo	PVC-U
2	Cone	Cono de cierre	PVC-U
3	Spring	Muelle	Stainless Steel AISI 302 / PTFE coated *
4	Union nut	Tuerca	PVC-U
5	End connector	Manguito enlace	PVC-U
6	Cone o-ring	Junta cono	EPDM / FPM
7	End connector o-ring	Junta manguito	EPDM / FPM
8	Seal-carrier	Portajuntas	PVC-U
9	Body o-ring	Junta cuerpo	EPDM / FPM



**PRESSURE / TEMPERATURE GRAPH**

**DIAGRAMA PRESIÓN / TEMPERATURA**



Life: 25 years  
Hydrostatic maximum pressure a component may withstand in continuous service (without overpressure)

*Vida útil: 25 años  
Presión hidrostática máxima que un componente es capaz de soportar en servicio continuo (sin sobrepresión)*

**PRESSURE LOSS DIAGRAM**

**DIAGRAMA DE PÉRDIDAS DE CARGA**

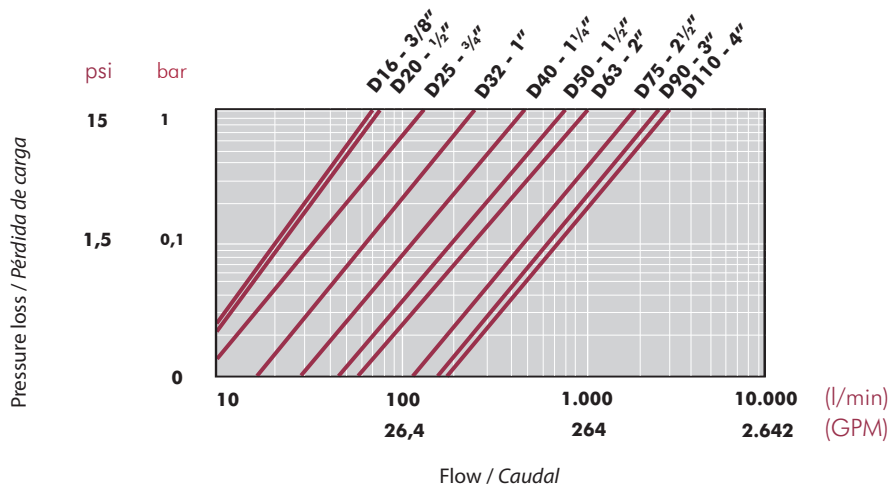

**RELATIVE FLOW**

**FLUJO RELATIVO**

D	20-1/2"	25-3/4"	32-1"	40-1 1/4"	50-1 1/2"	63-2"	75-2 1/2"
DN	15	20	25	32	40	50	65
Kv <sub>100</sub>	68	133	208	383	667	850	1533
Cv	5	9	15	27	47	60	107

$Cv = Kv_{100} / 14,28$   
 $Kv_{100}$  (l/min,  $\Delta p = 1$  bar)  
 $Cv$  (GPM,  $\Delta p = 1$  psi)

Relative flow in fully open valve (maximum opening)

Flujo relativo en válvula completamente abierta (apertura máxima)

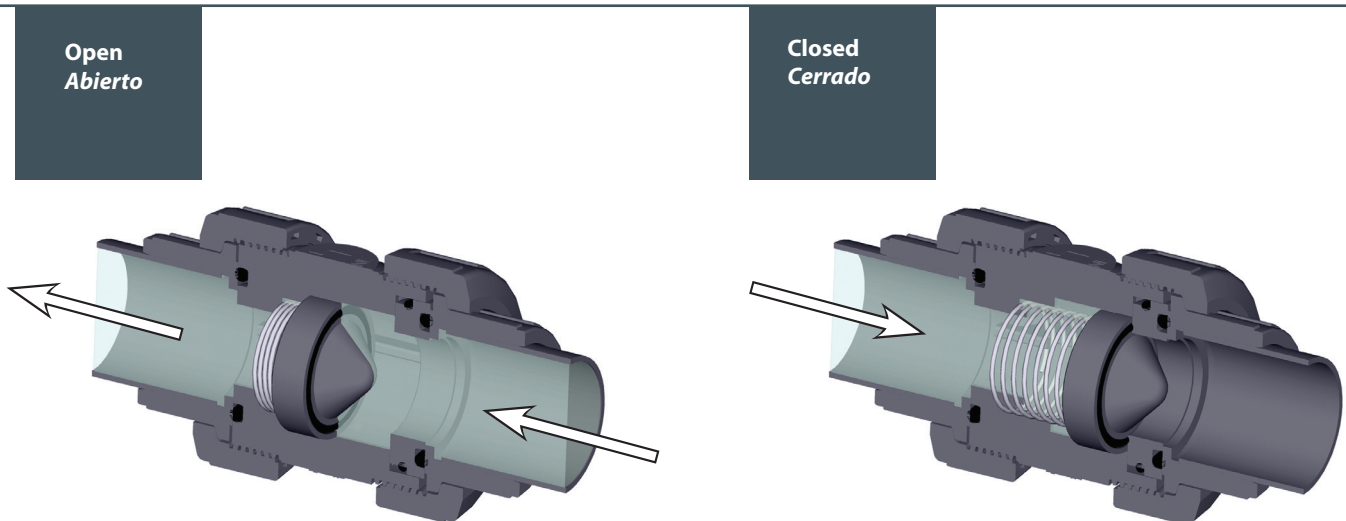

**OPENING PRESSURE**

**PRESIÓN DE APERTURA**

Minimum pressure: opening start  
 Maximum pressure: open valve

Minimum pressure: opening start  
 Maximum pressure: open valve

D	P (bar) Minimum opening	P (bar) Maximum opening	P (psi) Minimum opening	P (psi) Maximum opening
20	0,11	0,19	1,57	2,71
25	0,035	0,067	0,5	0,95
32	0,042	0,077	0,6	1,1
40	0,038	0,069	0,54	0,98
50	0,063	0,088	0,9	1,25
63	0,038	0,060	0,54	0,85
75	0,031	0,060	0,44	0,85
90	0,025	0,060	0,35	0,85



### ASSEMBLY INSTRUCTIONS

#### Solvent socket or threaded unions

Loosen the valve union nuts (4) and separate these and the end connectors (5) from the valve body. Pass the pipe through the nuts and then place the bushes over the end of the pipe. The socket unions should be glued onto the pipe using a PVC-U or PVC-C adhesive and pressure should not be applied to the system until a drying period of at least 1 hour per bar of working pressure has elapsed. In the case of threaded unions, PTFE tape should be applied to the male threads. The pipes can now be attached to the valve by hand tightening down the nuts.

### INSTRUCCIONES DE MONTAJE

#### Uniones encoladas o roscadas

Afloje las tuercas (4) de la válvula y sepárelas de los manguitos (5). Introduzca las tuercas en los tubos y a continuación fije los manguitos en los extremos del tubo. Las uniones encoladas se realizarán con un adhesivo para tubos de PVC-U o PVC-C rígido y no se aplicará presión hasta transcurridas al menos 1 hora por bar. En las uniones roscadas se colocará cinta de PTFE en las roscas macho. A continuación ya podrá colocarse la válvula entre los manguitos y apretar a mano las tuercas sobre la válvula.

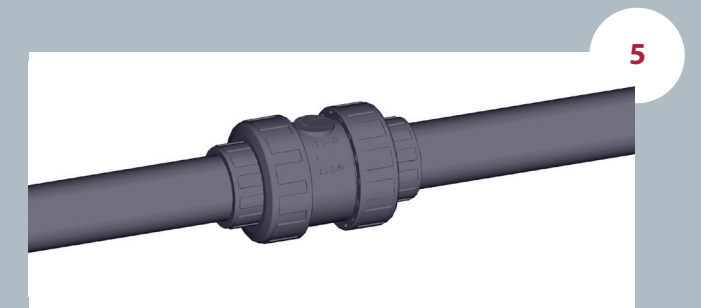
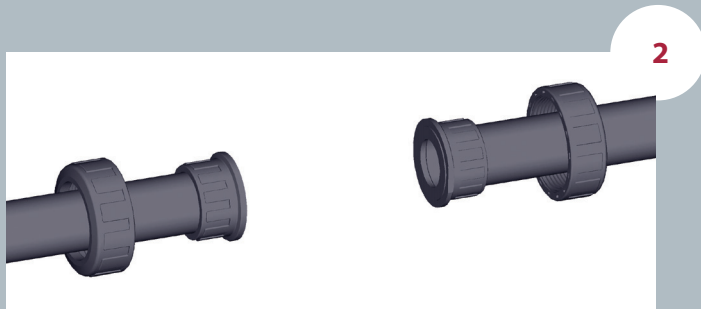
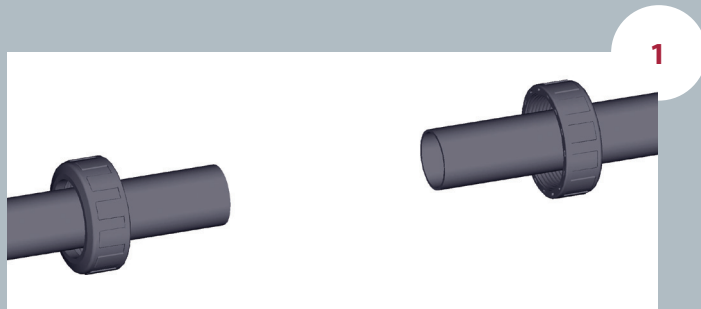

## UP-S. 67. SF1. BS - PVC-U SPRING CHECK VALVE

### Spring check valve

- PVC-U body
- Female solvent socket
- British Standard series
- O-Rings in EPDM

### Válvula anti-retorno

- Cuerpo en PVC-U
- Encolar hembra
- Serie British Standard
- Anillos tóricos en EPDM

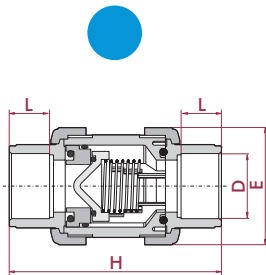

D	DN	PN	REF.	CODE
3/8"	10	16	05 67 900	<b>09109</b>
1/2"	15	16	05 67 901	<b>09110</b>
3/4"	20	16	05 67 902	<b>09111</b>
1"	25	16	05 67 903	<b>09112</b>
1 1/4"	32	16	05 67 904	<b>09113</b>
1 1/2"	40	16	05 67 905	<b>09114</b>
2"	50	16	05 67 906	<b>09115</b>
2 1/2"	65	10	05 67 075 <sup>M</sup>	<b>09017</b>
3"	80	10	05 67 908	<b>09117</b>
4"	100	10	05 67 910	<b>09118</b>

L	H	E
16	84	52
16	84	52
19	108	62
22	119	70
26	142	84
31	162	94
38	192	117
44	232	148
51	269	179
61	279	179

PVC-C valves on order  
 Válvulas en PVC-C bajo pedido

## PVC-U FOOT VALVES - SPRING SERIES

### VÁLVULAS DE PIE PVC-U - SERIE MUELLE



Sizes	Solvent cement D16 - D110 (DN10 - DN100) Threaded 3/8" - 4"	
Standards	Solvent socket - Metric, British standard, ASTM, JIS Threaded - BSP, NPT	EN ISO 1452, EN ISO 15493, BS 4346-1, ASTM D 2467, JIS K 6743 ISO 228-1, ASTM D 2464
Working pressure	@ 20°C (73°F)  D16-D63 (3/8" - 2"): PN 16 (240 psi) D75 - D110 (2 1/2" - 4"): PN 10 (150 psi)	
Minimum working pressure		
Materials	O-rings: EPDM / FPM	
Characteristics	<ul style="list-style-type: none"> <li>• <b>May be used either vertically and horizontally.</b></li> <li>• 100% factory tested.</li> <li>• Easy installation and maintenance.</li> <li>• Available in PVC-U and Corzan® PVC-C.</li> <li>• Resistance to many inorganic chemicals.</li> <li>• Excellent flow characteristics.</li> </ul>	<ul style="list-style-type: none"> <li>• <b>Se pueden usar indistintamente verticalmente o horizontalmente.</b></li> <li>• Probadas al 100% en fábrica.</li> <li>• Fácil instalación y mantenimiento.</li> <li>• Disponibles en PVC-U y Corzan® PVC-C.</li> <li>• Resistencia a múltiples sustancias químicas inorgánicas.</li> <li>• Excelentes características de conducción.</li> </ul>
Certifications / regulations	Check valve design regulation - ISO 16137:2006	

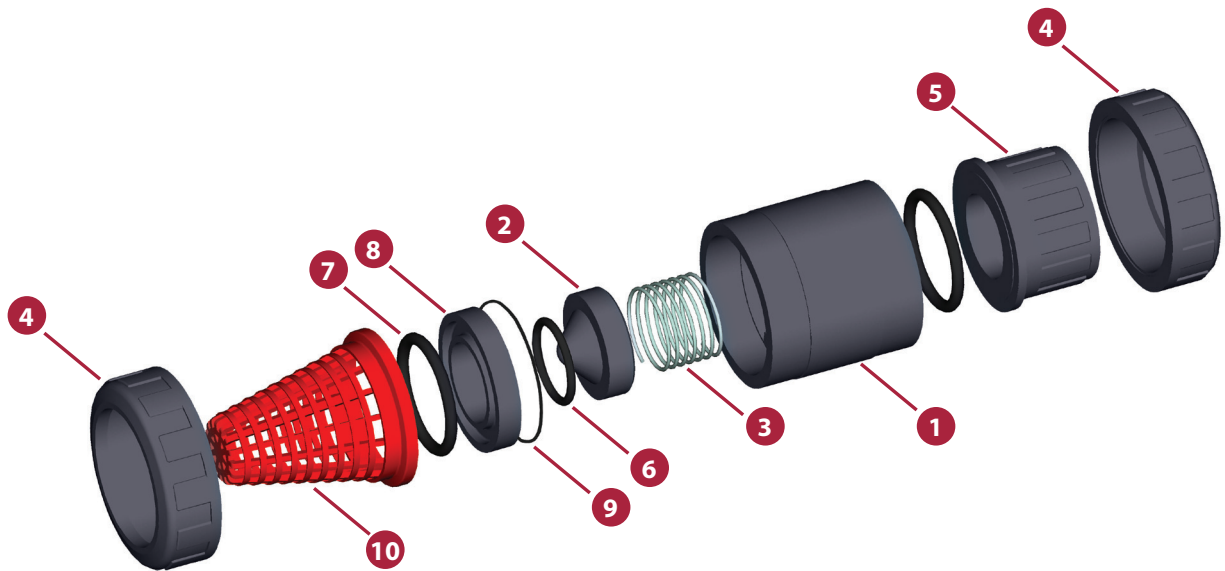
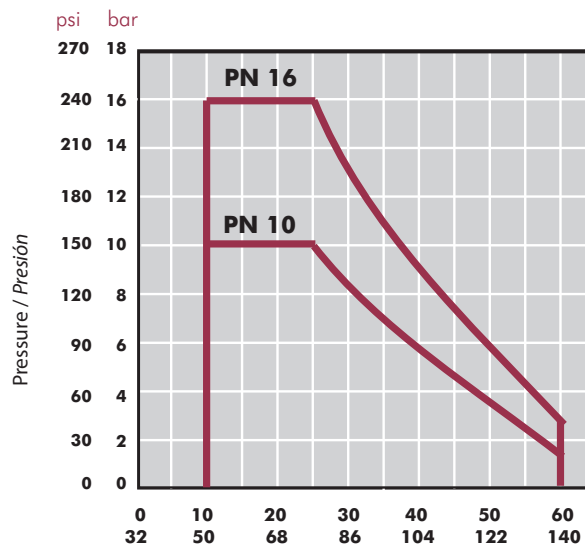

FIG.	Parts	Despiece	Material
1	Body	Cuerpo	PVC-U / PVC-C
2	Cone	Cono de cierre	PVC-U / PVC-C
3	Spring	Muelle	Staniless Steel AISI 302
4	Union nut	Tuerca	PVC-U / PVC-C
5	End connector	Manguito enlace	PVC-U / PVC-C
6	Cone o-ring	Junta cono	EPDM / FPM
7	End connector o-ring	Junta manguito	EPDM / FPM
8	Seal-carrier	Portajuntas	PVC-U / PVC-C
9	Body o-ring	Junta cuerpo	EPDM / FPM
10	Foot valve screen	Rejilla	PP

**PRESSURE / TEMPERATURE GRAPH**  
**DIAGRAMA PRESIÓN / TEMPERATURA**



Life: 25 years  
 Hydrostatic maximum pressure a component may withstand in continuous service (without overpressure)

Vida útil: 25 años  
 Presión hidrostática máxima que un componente es capaz de soportar en servicio continuo (sin sobrepresión)

**PRESSURE LOSS DIAGRAM**
**DIAGRAMA DE PÉRDIDAS DE CARGA**

D16 - 3/8"		D20 - 1/2"		D25 - 3/4"		D32 - 1"		D40 - 1 1/4"		D50 - 1 1/2"		D63 - 2"		D75 - 2 1/2"		D90 - 3"		D110 - 4"	
A	B	A	B	A	B	A	B	A	B	A	B	A	B	A	B	A	B	A	B
0,42	0,34	0,44	0,34	0,54	0,17	0,35	0,13	3,15	0,13	25,85	0,38	39,80	0,70	50,00	0,40	83,50	0,45	77,2	0,46
0,85	0,52	0,92	0,58	1,06	0,22	1,13	0,18	5,20	0,12	20,70	0,27	34,50	0,48	44,20	0,29	74,80	0,39	67,5	0,36
1,35	0,58	1,60	0,19	1,65	0,15	1,62	0,15	7,35	0,16	17,50	0,19	27,50	0,28	36,50	0,23	64,90	0,31	60,1	0,30
2,08	0,28	2,05	0,18	2,18	0,18	2,02	0,14	9,38	0,21	12,30	0,11	21,15	0,17	30,90	0,20	50,38	0,21	49,6	0,22
2,44	0,34	2,48	0,22	3,21	0,29	2,59	0,14	12,17	0,31	8,86	0,09	12,65	0,09	25,50	0,15	43,08	0,18	41,1	0,18
2,80	0,60	3,10	0,30	3,91	0,38	3,07	0,15	15,05	0,43	3,22	0,09	6,25	0,08	20,35	0,12	35,22	0,14	31,5	0,14
-	-	3,53	0,35	4,32	0,44	3,51	0,16	-	-	-	-	-	-	12,30	0,11	28,75	0,11	24,6	0,13
-	-	-	-	-	-	4,20	0,20	-	-	-	-	-	-	6,27	0,11	18,02	0,08	15,8	0,01
-	-	-	-	-	-	-	-	-	-	-	-	-	-	-	-	8,28	0,11	7,9	0,08
-	-	-	-	-	-	-	-	-	-	-	-	-	-	-	-	-	-	-	-

**A =** Flow (m<sup>3</sup>/h)  
Caudal (m<sup>3</sup>/h)

**B =** Pressure loss (bar)  
Pérdida de carga (bar)

**OPENING PRESSURE**
**PRESIÓN DE APERTURA**

Minimum pressure: opening start  
Maximum pressure: open valve

Minimum pressure: opening start  
Maximum pressure: open valve

D	P (bar) Minimum opening	P (bar) Maximum opening	P (PSI) Minimum opening	P (PSI) Maximum opening
20	0,11	0,19	1,57	2,71
25	0,035	0,067	0,5	0,95
32	0,042	0,077	0,6	1,1
40	0,038	0,069	0,54	0,98
50	0,063	0,088	0,9	1,25
63	0,038	0,060	0,54	0,85
75	0,031	0,060	0,44	0,85
90	0,025	0,060	0,35	0,85

**UP-S. 66. SF1. BS - PVC-U SPRING FOOT CHECK VALVE**
**Foot valve**

- PVC-U body
- Female solvent socket
- British Standard series
- O-Rings in EPDM

**Válvula de pie**

- Cuerpo en PVC-U
- Encolar hembra
- Serie British Standard
- Anillos tóricos en EPDM

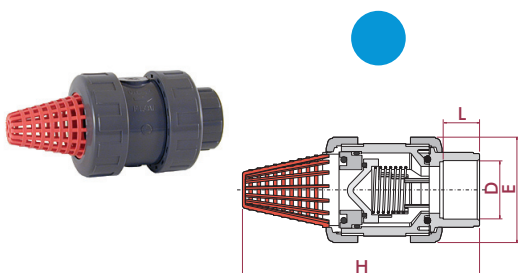

D	DN	PN	REF.	CODE
3/8"	10	16	05 66 900	<b>09099</b>
1/2"	15	16	05 66 901	<b>09100</b>
3/4"	20	16	05 66 902	<b>09101</b>
1"	25	16	05 66 903	<b>09102</b>
1 1/4"	32	16	05 66 904	<b>09103</b>
1 1/2"	40	16	05 66 905	<b>09104</b>
2"	50	16	05 66 906	<b>09105</b>
2 1/2"	65	10	05 66 075 <sup>M</sup>	<b>08997</b>
3"	80	10	05 66 908	<b>09107</b>
4"	100	10	05 66 910	<b>09108</b>

L	H	E
16	107	52
16	107	52
19	130	62
22	154	70
26	176	84
31	202	94
38	239	117
44	306	148
51	362	179
61	367	179

## PVC-U CHECK VALVES - UNIBLOCK SERIES

### VÁLVULAS ANTI-RETORNO PVC-U - SERIE UNIBLOCK



Sizes	Solvent cement D20 - D110 (DN15 - DN100) Threaded ½" - 4"	
Standards	Solvent socket - Metric Threaded - BSP	EN ISO 1452, EN ISO 15493 ISO 228-1
Working pressure	@ 20°C (73°F)  D20-D63 (½" - 2"): PN 16 (240 psi) D75 - D110 (2½" - 4"): PN 10 (150 psi)	
Minimum working pressure		
Materials	O-rings: EPDM	
Characteristics	<ul style="list-style-type: none"> <li>• <b>May be used either vertically and horizontally.</b></li> <li>• 100% factory tested.</li> <li>• Easy installation and maintenance.</li> <li>• Available in PVC-U.</li> <li>• Resistance to many inorganic chemicals.</li> <li>• Excellent flow characteristics.</li> </ul>	<ul style="list-style-type: none"> <li>• <b>Se pueden usar indistintamente verticalmente o horizontalmente.</b></li> <li>• Probadas al 100% en fábrica.</li> <li>• Fácil instalación y mantenimiento.</li> <li>• Disponibles en PVC-U.</li> <li>• Resistencia a múltiples sustancias químicas inorgánicas.</li> <li>• Excelentes características de conducción.</li> </ul>
Certifications / regulations	Check valve design regulation - ISO 16137:2006	

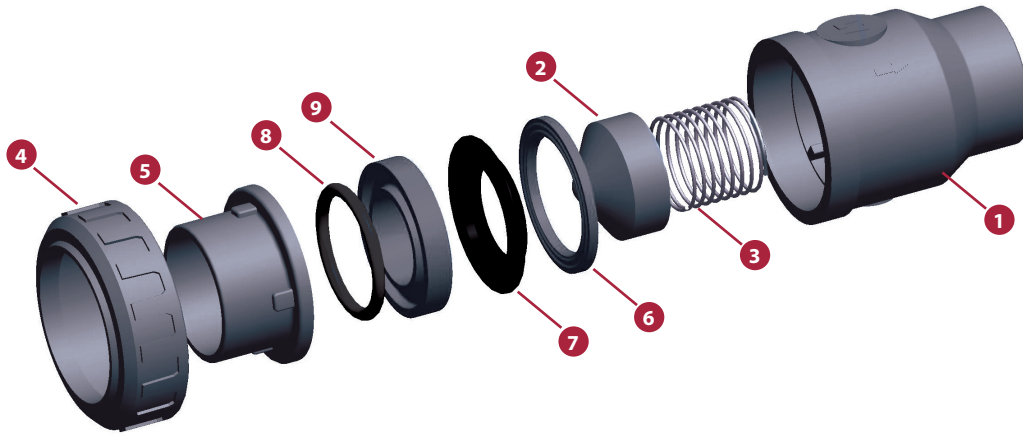
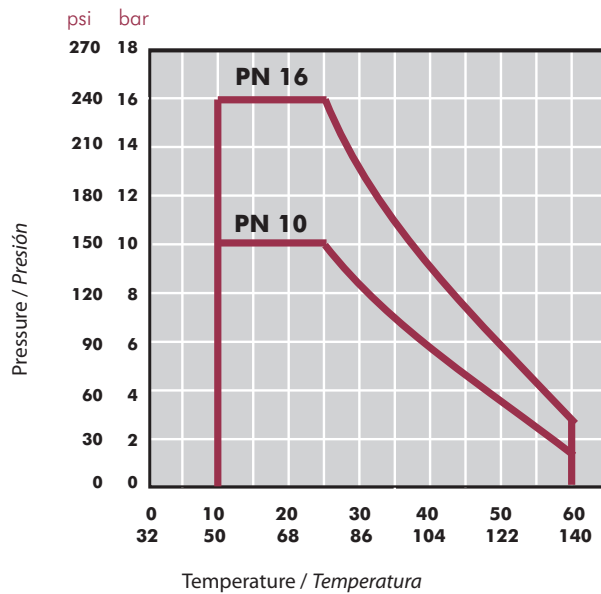

FIG.	Parts	Despiece	Material
1	Body	Cuerpo	PVC-U
2	Cone	Cono de cierre	PVC-U
3	Spring	Muelle	Stainless steel AISI 302
4	Union nut	Tuerca	PVC-U
5	End connector	Manguito enlace	PVC-U
6	Cone o-ring	Junta cono	EPDM
7	Body o-ring	Junta cuerpo	EPDM
8	End connector o-ring	Junta manguito	EPDM
9	Seal-carrier	Portajuntas	PVC-U

**PRESSURE / TEMPERATURE GRAPH**  
**DIAGRAMA PRESIÓN / TEMPERATURA**



Life: 25 years  
 Hydrostatic maximum pressure a component may withstand in continuous service (without overpressure)

Vida útil: 25 años  
 Presión hidrostática máxima que un componente es capaz de soportar en servicio continuo (sin sobrepresión)

**PRESSURE LOSS DIAGRAM**

**DIAGRAMA DE PÉRDIDAS DE CARGA**

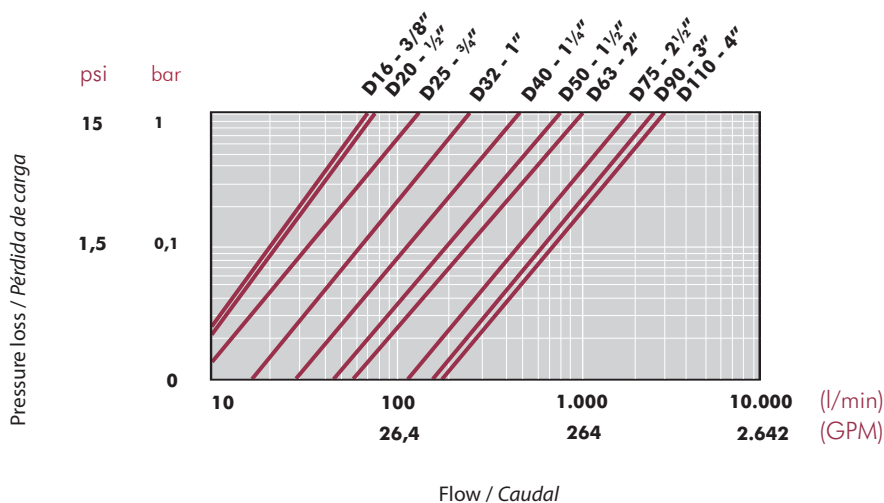

**RELATIVE FLOW**

**FLUJO RELATIVO**

D	20-1/2"	25-3/4"	32-1"	40-1 1/4"	50-1 1/2"	63-2"	75-2 1/2"	90-3"	110-4"
DN	15	20	25	32	40	50	65	80	100
Kv <sub>100</sub>	68	133	208	383	667	850	1533	1160	1200
Cv	5	9	15	27	47	60	107	81,2	84

$Cv = Kv_{100} / 14,28$   
 $Kv_{100}$  (l/min, Δp = 1 bar)  
 $Cv$  (GPM, Δp = 1 psi)

Relative flow in fully open valve (maximum opening)  
 Flujo relativo en válvula completamente abierta (apertura máxima)

**OPENING PRESSURE**

**PRESIÓN DE APERTURA**

Minimum pressure: opening start  
 Maximum pressure: fully open valve

Presión mínima: inicio apertura  
 Presión máxima: válvula completamente abierta

D	P (bar) Minimum opening	P (bar) Maximum opening	P (psi) Minimum opening	P (psi) Maximum opening
20	0,11	0,19	1,57	2,71
25	0,035	0,067	0,5	0,95
32	0,042	0,077	0,6	1,1
40	0,038	0,069	0,54	0,98
50	0,063	0,088	0,9	1,25
63	0,038	0,060	0,54	0,85
75	0,031	0,060	0,44	0,85
90	0,025	0,060	0,35	0,85

UP-B. **67**. SF1. BS - PVC-U UNIBLOCK CHECK VALVE

**Uniblock check valve**

- PVC-U body
- Female solvent socket
- British Standard series
- O-rings in EPDM

**Válvula anti-retorno Uniblock**

- Cuerpo en PVC-U
- Encolar hembra
- Serie British Standard
- Anillos tóricos en EPDM

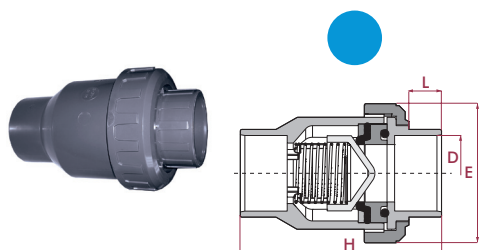

D	DN	PN	REF.	CODE
1/2"	15	16	05 93 901	<b>36770</b>
3/4"	20	16	05 93 902	<b>36771</b>
1"	25	16	05 93 903	<b>36772</b>
1 1/4"	32	16	05 93 904	<b>36773</b>
1 1/2"	40	16	05 93 905	<b>36774</b>
2"	50	16	05 93 906	<b>36775</b>
2 1/2"	65	10	05 93 075	<b>36565</b>
3"	80	10	05 93 908	<b>36776</b>
4"	100	10	05 93 911	<b>36777</b>

L	H	E
16	81	52
19	103	60
22	117	69
26	135	84
31	135	94
38	169	116
44	220	128
51	256	178
63	331	228



## PVC-U CHECK VALVES - BALL SERIES

### VÁLVULAS ANTI-RETORNO PVC-U - SERIE BOLA



Sizes	Solvent cement D20 - D110 (DN15 - DN100) Threaded ½" - 4"	
Standards	Solvent socket - Metric, British standard, ASTM, JIS Threaded - BSP, NPT	EN ISO 1452, EN ISO 15493, BS 4346-1, ASTM D 2467, JIS K 6743 ISO 228-1, ASTM D 2464
Working pressure	@ 20°C (73°F)  D20-D63 (½" - 2"): PN 16 (240 psi) D75 - D110 (2½" - 4"): PN 10 (150 psi)	
Minimum return pressure	<b>0,2 bar (3 psi)</b> <b>Minimal downstream pressure to keep the valve closed in horizontal position.</b> <b>Presión mínima aguas abajo para mantener la válvula cerrada en caso de instalación horizontal.</b>	
Materials	O-rings: EPDM / FPM	
Characteristics	<ul style="list-style-type: none"> <li>• <b>Completely made in plastic - corrosion free.</b></li> <li>• 100% factory tested.</li> <li>• Excellent flow rate.</li> <li>• Easy installation and maintenance.</li> <li>• May be used either vertically and horizontally.</li> <li>• Available in PVC-U and Corzan® PVC-C.</li> <li>• Resistance to many inorganic chemicals.</li> <li>• Excellent flow characteristics.</li> </ul>	<ul style="list-style-type: none"> <li>• <b>Fabricada completamente en plástico - libre de corrosión.</b></li> <li>• Probadas al 100% en fábrica.</li> <li>• Excelente coeficiente de caudal.</li> <li>• Fácil instalación y mantenimiento.</li> <li>• Se pueden usar indistintamente verticalmente o horizontalmente.</li> <li>• Disponibles en PVC-U y Corzan® PVC-C.</li> <li>• Resistencia a múltiples sustancias químicas inorgánicas.</li> <li>• Excelentes características de conducción.</li> </ul>
Certifications / regulations	Check valve design regulation - ISO 16137:2006	

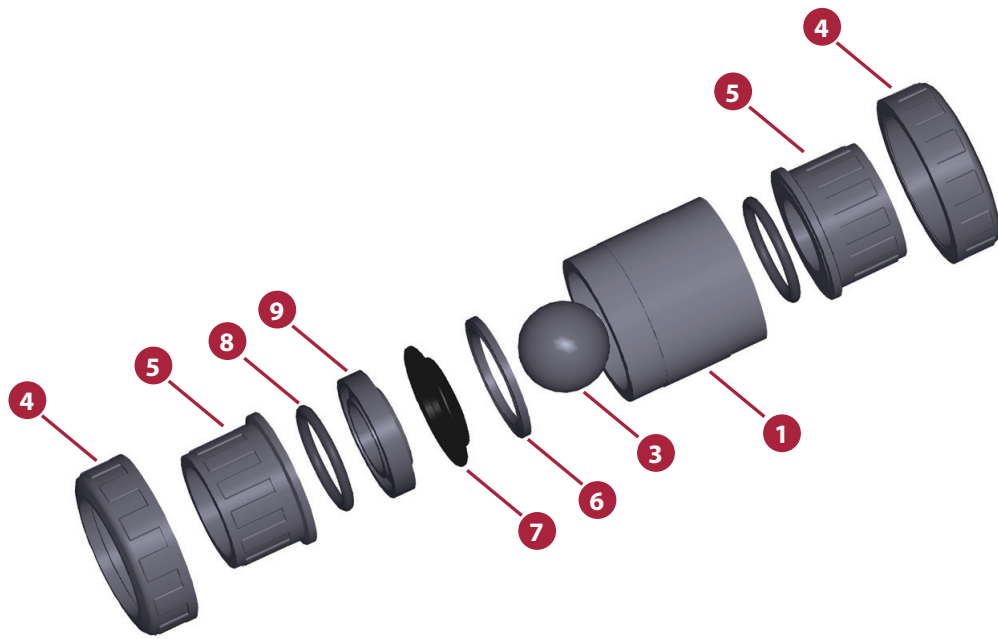
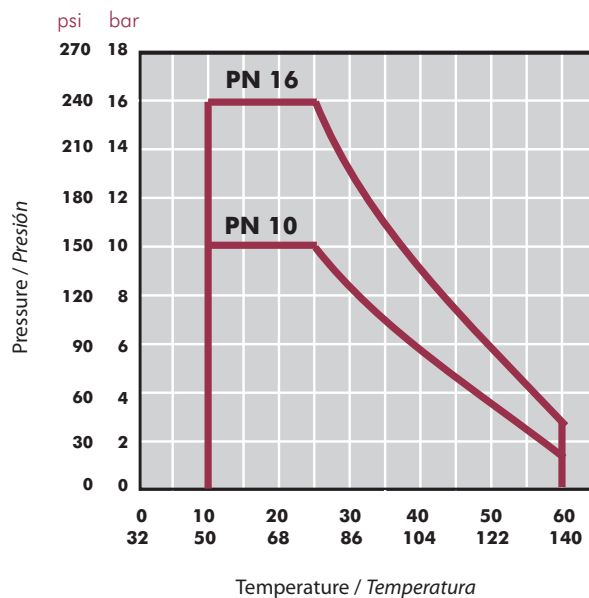

FIG.	Parts	Despiece	Material
1	Body	Cuerpo	PVC-U
3	Ball	Bola	PVC-U
4	Union nut	Tuerca	PVC-U
5	End connector	Manguito enlace	PVC-U
6	Closing ring	Anillo de cierre	PVC-U
7	Body o-ring	Junta cuerpo	EPDM / FPM
8	End connector o-ring	Junta manguito	EPDM / FPM
9	Seal-carrier	Portajuntas	PVC-U

**PRESSURE / TEMPERATURE GRAPH**  
**DIAGRAMA PRESIÓN / TEMPERATURA**



Life: 25 years  
 Hydrostatic maximum pressure a component may withstand in continuous service (without overpressure)

Vida útil: 25 años  
 Presión hidrostática máxima que un componente es capaz de soportar en servicio continuo (sin sobrepresión)

**PRESSURE LOSS DIAGRAM**  
**DIAGRAMA DE PÉRDIDAS DE CARGA**

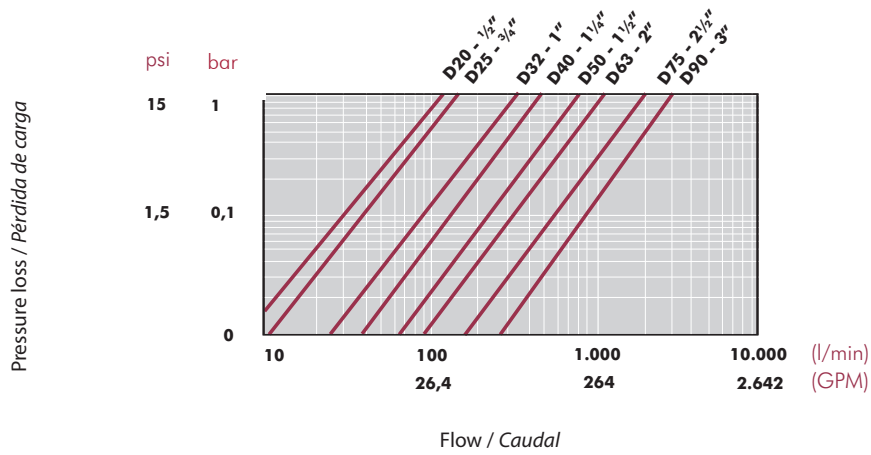

**RELATIVE FLOW**  
**FLUJO RELATIVO**

D	20-1/2"	25-3/4"	32-1"	40-1 1/4"	50-1 1/2"	63-2"	75-2 1/2"	90-3"
DN	15	20	25	32	40	50	65	80
$Kv_{100}$	99	128	308	453	795	1040	1932	2754
$Cv$	7	9	22	32	56	73	135	193

$Cv = Kv_{100} / 14,28$   
 $Kv_{100}$  (l/min,  $\Delta p = 1$  bar)  
 $Cv$  (GPM,  $\Delta p = 1$  psi)

**Open**  
**Abierto**

**Closed**  
**Cerrado**

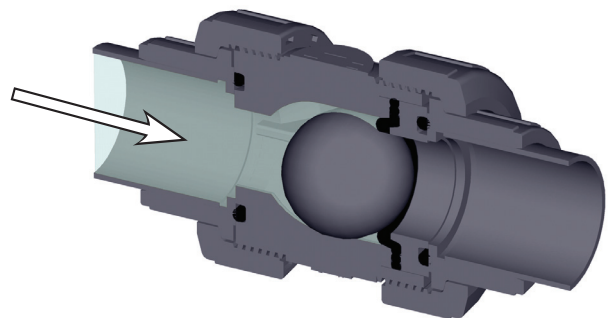
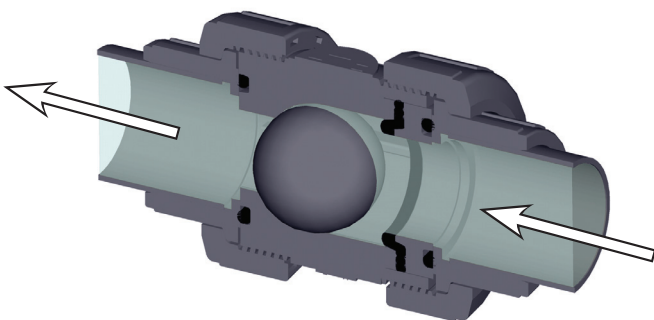

## ASSEMBLY INSTRUCTIONS

### Solvent socket or threaded unions

Loosen the valve union nuts (4) and separate these and the end connectors (5) from the valve body. Pass the pipe through the nuts and then place the bushes over the end of the pipe. The socket unions should be glued onto the pipe using a PVC-U or PVC-C adhesive and pressure should not be applied to the system until a drying period of at least 1 hour per bar of working pressure has elapsed. In the case of threaded unions, PTFE tape should be applied to the male threads. The pipes can now be attached to the valve by hand tightening down the nuts.

## INSTRUCCIONES DE MONTAJE

### Uniones encoladas o roscadas

Afloje las tuercas (4) de la válvula y sepárelas de los manguitos (5). Introduzca las tuercas en los tubos y a continuación fije los manguitos en los extremos del tubo. Las uniones encoladas se realizarán con un adhesivo para tubos de PVC-U o PVC-C rígido y no se aplicará presión hasta transcurridas al menos 1 hora por bar. En las uniones roscadas se colocará cinta de PTFE en las roscas macho. A continuación ya podrá colocarse la válvula entre los manguitos y apretar a mano las tuercas sobre la válvula.

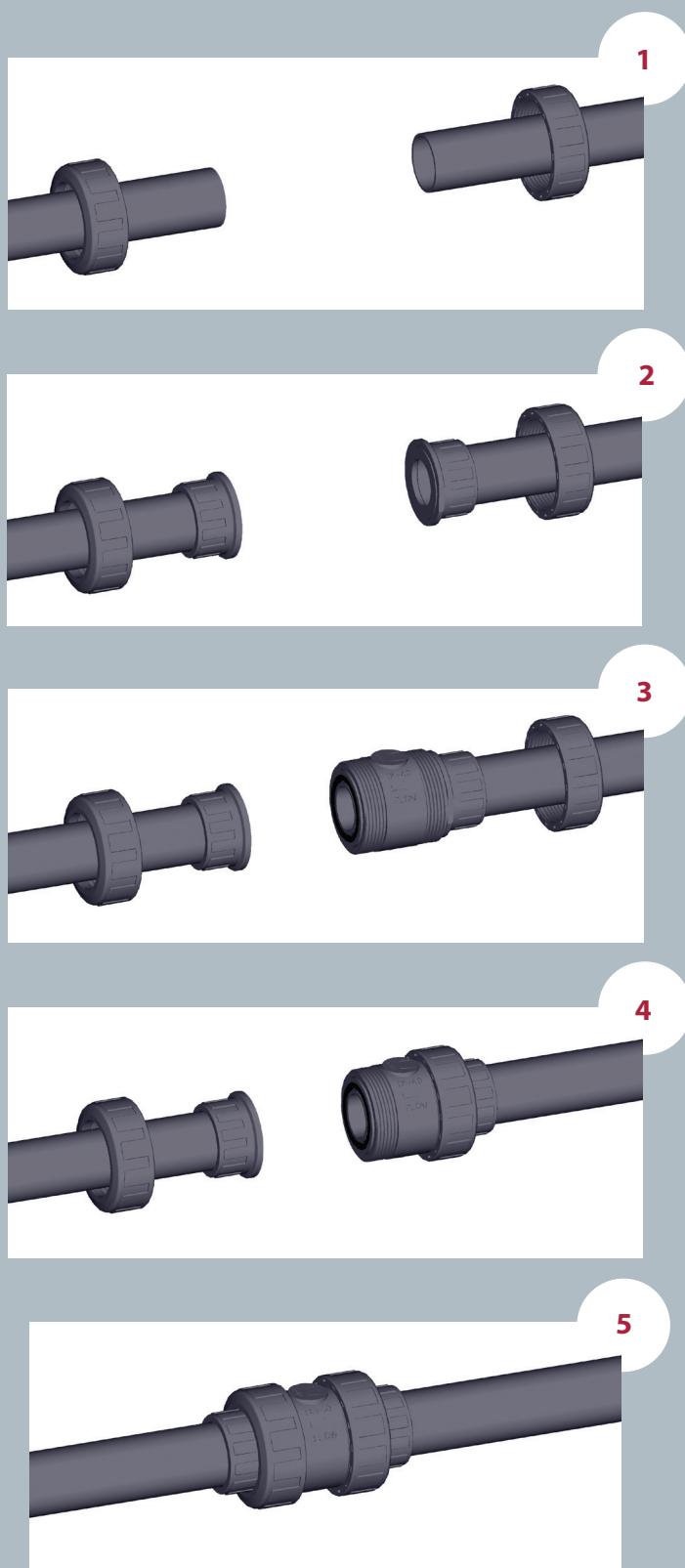

## UP-B. 67. SF1. BS - PVC-U BALL CHECK VALVE

**Ball check valve**

- PVC-U body
- Female solvent socket
- British Standard series
- O-rings in EPDM

**Válvula anti-retorno de bola**

- Cuerpo en PVC-U
- Encolar hembra
- Serie British Standard
- Anillos tóricos en EPDM

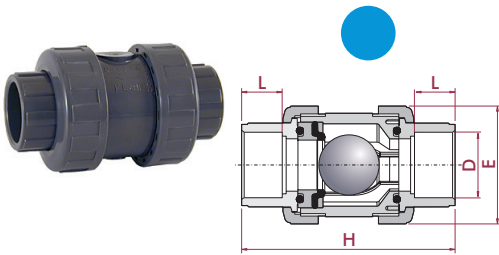

D	DN	PN	REF.	CODE
½"	15	16	05 67 901 E	<b>33010</b>
¾"	20	16	05 67 902 E	<b>33011</b>
1"	25	16	05 67 903 E	<b>33012</b>
1¼"	32	16	05 67 904 E	<b>33013</b>
1½"	40	16	05 67 905 E	<b>33014</b>
2"	50	16	05 67 906 E	<b>33015</b>

L	H	E
16	84	52
19	108	62
22	119	70
26	142	84
31	162	94
38	192	117

## UP-B. 67. SF4. BS - PVC-U BALL CHECK VALVE

**Ball check valve**

- PVC-U body
- Female solvent socket
- British Standard series
- O-rings in FPM

**Válvula anti-retorno de bola**

- Cuerpo en PVC-U
- Encolar hembra
- Serie British Standard
- Anillos tóricos en FPM

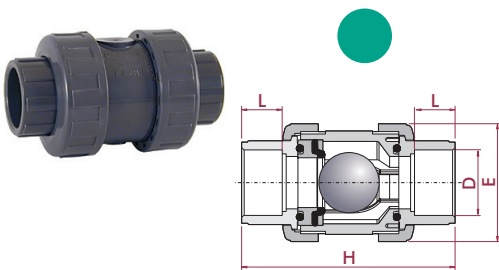

D	DN	PN	REF.	CODE
½"	15	16	05 67 901 VE	<b>33016</b>
¾"	20	16	05 67 902 VE	<b>33017</b>
1"	25	16	05 67 903 VE	<b>33018</b>
1¼"	32	16	05 67 904 VE	<b>33019</b>
1½"	40	16	05 67 905 VE	<b>33020</b>
2"	50	16	05 67 906 VE	<b>33021</b>

L	H	E
16	84	52
19	108	62
22	119	70
26	142	84
31	162	94
38	192	117

## PVC-U CHECK VALVES - SPRING SERIES

### VÁLVULAS ANTI-RETORNO PVC-U - SERIE MUELLE



Sizes	Solvent cement D16 - D110 (DN10 - DN100) Threaded 3/8" - 4"	
Standards	Solvent socket - Metric, British standard, ASTM, JIS Threaded - BSP, NPT	EN ISO 1452, EN ISO 15493, BS 4346-1, ASTM D 2467, JIS K 6743 ISO 228-1, ASTM D 2464
Working pressure	@ 20°C (73°F)  D16-D63 (3/8" - 2"): PN 16 (240 psi) D75 - D110 (2" 1/2 - 4"): PN 10 (150 psi)	
Minimum working pressure		
Materials	O-rings: EPDM / FPM	
Characteristics	<ul style="list-style-type: none"> <li>• <b>May be used either vertically and horizontally.</b></li> <li>• 100% factory tested.</li> <li>• Easy installation and maintenance.</li> <li>• Available in PVC-U and Corzan® PVC-C.</li> <li>• Resistance to many inorganic chemicals.</li> <li>• Excellent flow characteristics.</li> </ul>	<ul style="list-style-type: none"> <li>• <b>Se pueden usar indistintamente verticalmente o horizontalmente.</b></li> <li>• Probadas al 100% en fábrica.</li> <li>• Fácil instalación y mantenimiento.</li> <li>• Disponibles en PVC-U y Corzan® PVC-C.</li> <li>• Resistencia a múltiples sustancias químicas inorgánicas.</li> <li>• Excelentes características de conducción.</li> </ul>
Certifications / regulations	Check valve design regulation - ISO 16137:2006	

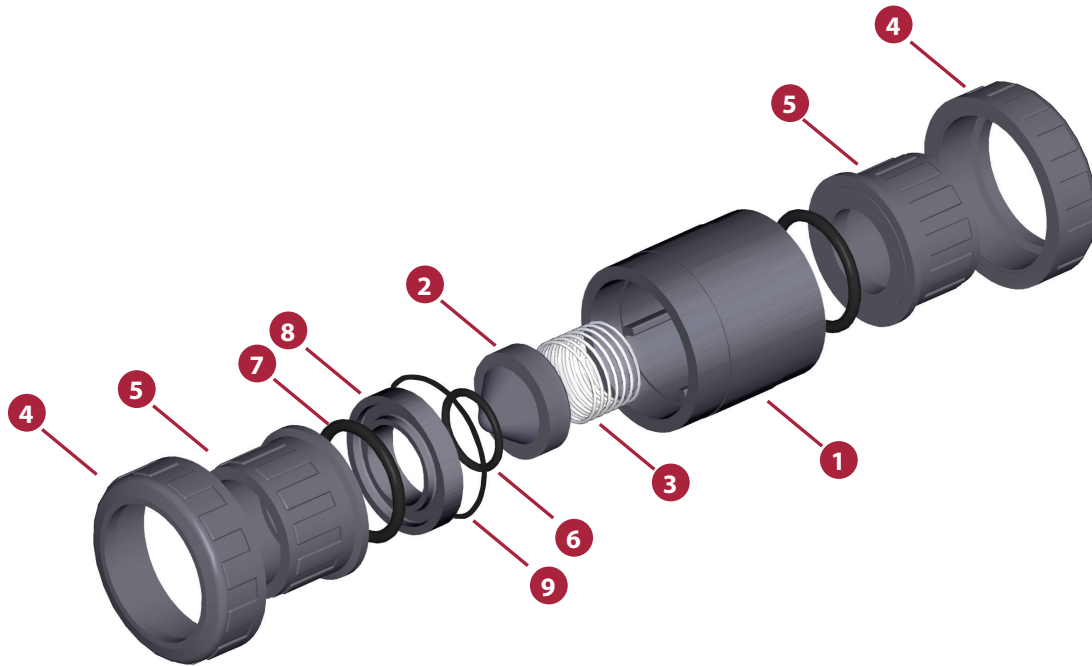
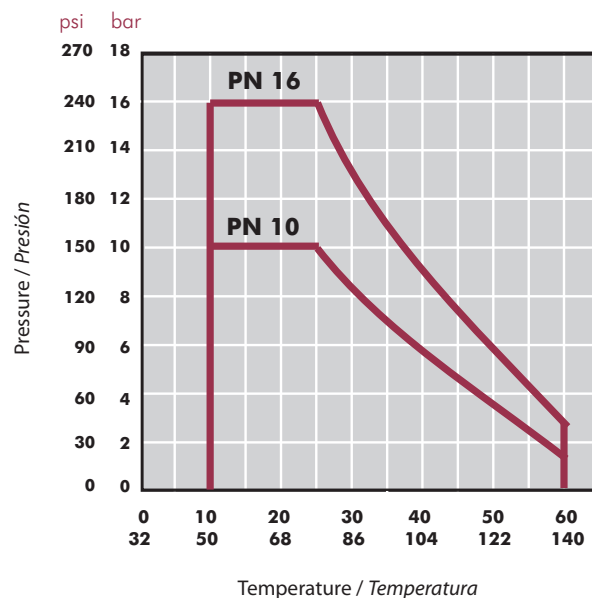

FIG.	Parts	Despiece	Material
1	Body	Cuerpo	PVC-U
2	Cone	Cono de cierre	PVC-U
3	Spring	Muelle	Stainless Steel AISI 302 / PTFE coated *
4	Union nut	Tuerca	PVC-U
5	End connector	Manguito enlace	PVC-U
6	Cone o-ring	Junta cono	EPDM / FPM
7	End connector o-ring	Junta manguito	EPDM / FPM
8	Seal-carrier	Portajuntas	PVC-U
9	Body o-ring	Junta cuerpo	EPDM / FPM

**PRESSURE / TEMPERATURE GRAPH**  
**DIAGRAMA PRESIÓN / TEMPERATURA**



Life: 25 years  
 Hydrostatic maximum pressure a component may withstand in continuous service (without overpressure)

Vida útil: 25 años  
 Presión hidrostática máxima que un componente es capaz de soportar en servicio continuo (sin sobrepresión)

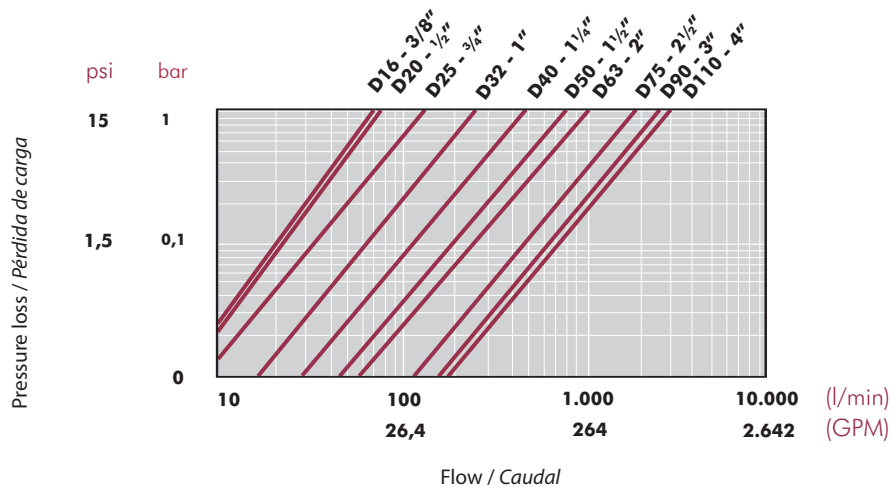
**PRESSURE LOSS DIAGRAM**
**DIAGRAMA DE PÉRDIDAS DE CARGA**

**RELATIVE FLOW**
**FLUJO RELATIVO**

D	20-1/2"	25-3/4"	32-1"	40-1 1/4"	50-1 1/2"	63-2"	75-2 1/2"	90-3"	110-4"
DN	15	20	25	32	40	50	65	80	100
Kv <sub>100</sub>	68	133	208	383	667	850	1533	1160	1200
Cv	5	9	15	27	47	60	107	81,2	84

$$Cv = Kv_{100} / 14,28$$

$$Kv_{100} \text{ (l/min, } \Delta p = 1 \text{ bar)}$$

$$Cv \text{ (GPM, } \Delta p = 1 \text{ psi)}$$

Relative flow in fully open valve (maximum opening)

Flujo relativo en válvula completamente abierta (apertura máxima)

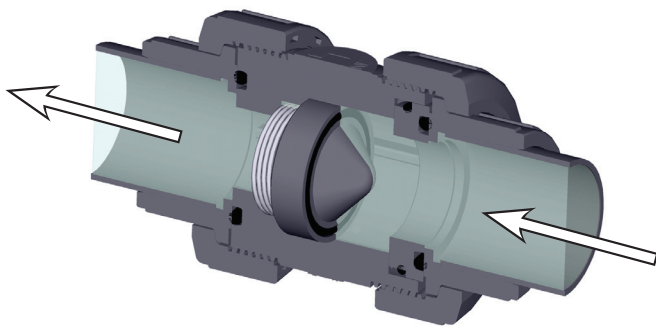
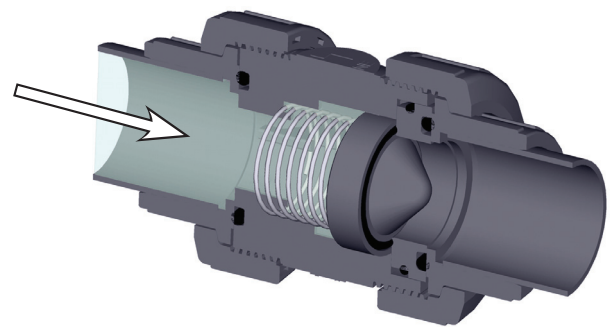
**Open**  
**Abierto**

**Closed**  
**Cerrado**

**OPENING PRESSURE**
**PRESIÓN DE APERTURA**

 Minimum pressure: opening start  
 Maximum pressure: fully open valve

 Presión mínima: inicio apertura  
 Presión máxima: válvula completamente abierta

D	P (bar) Minimum opening	P (bar) Maximum opening	P (psi) Minimum opening	P (psi) Maximum opening
20	0,11	0,19	1,57	2,71
25	0,035	0,067	0,5	0,95
32	0,042	0,077	0,6	1,1
40	0,038	0,069	0,54	0,98
50	0,063	0,088	0,9	1,25
63	0,038	0,060	0,54	0,85
75	0,031	0,060	0,44	0,85
90	0,025	0,060	0,35	0,85



## ASSEMBLY INSTRUCTIONS

### Solvent socket or threaded unions

Loosen the valve union nuts (4) and separate these and the end connectors (5) from the valve body. Pass the pipe through the nuts and then place the bushes over the end of the pipe. The socket unions should be glued onto the pipe using a PVC-U or PVC-C adhesive and pressure should not be applied to the system until a drying period of at least 1 hour per bar of working pressure has elapsed. In the case of threaded unions, PTFE tape should be applied to the male threads. The pipes can now be attached to the valve by hand tightening down the nuts.

## INSTRUCCIONES DE MONTAJE

### Uniones encoladas o roscadas

Afloje las tuercas (4) de la válvula y sepárelas de los manguitos (5). Introduzca las tuercas en los tubos y a continuación fije los manguitos en los extremos del tubo. Las uniones encoladas se realizarán con un adhesivo para tubos de PVC-U o PVC-C rígido y no se aplicará presión hasta transcurridas al menos 1 hora por bar. En las uniones roscadas se colocará cinta de PTFE en las roscas macho. A continuación ya podrá colocarse la válvula entre los manguitos y apretar a mano las tuercas sobre la válvula.

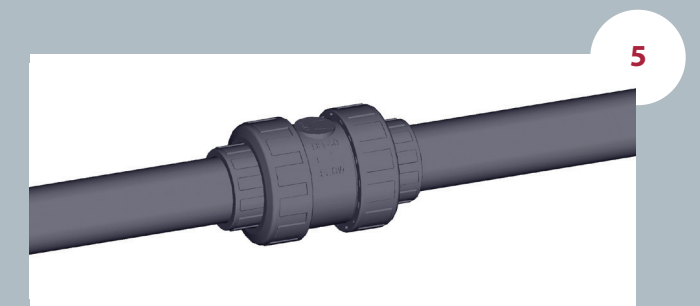
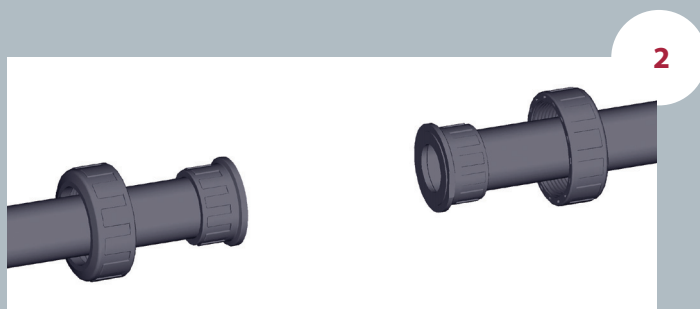
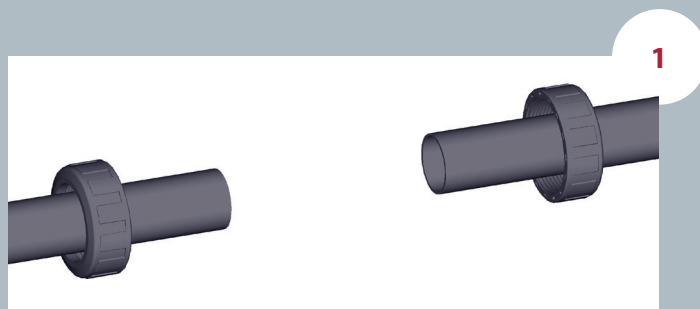

## UP-S. 67. SF1. MA - PVC-U SPRING CHECK VALVE

**Spring check valve**

- PVC-U body
- Female solvent socket
- ASTM series
- O-Rings in EPDM

**Válvula anti-retorno**

- Cuerpo en PVC-U
- Encolar hembra
- Serie ASTM
- Anillos tóricos en EPDM

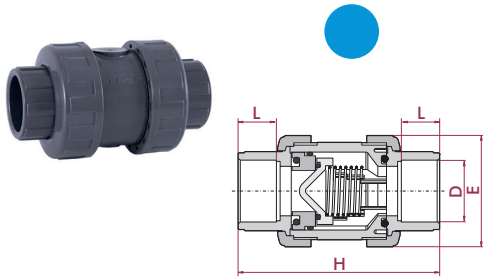

D	DN	PN	REF.	CODE
3/4"	15	16	05 67 900 MA	<b>07419</b>
1/2"	15	16	05 67 901 MA	<b>06998</b>
3/4"	20	16	05 67 902 MA	<b>06999</b>
1"	25	16	05 67 903 MA	<b>07000</b>
1 1/4"	32	16	05 67 904 MA	<b>07001</b>
1 1/2"	40	16	05 67 905 MA	<b>07002</b>
2"	50	16	05 67 906 MA	<b>07003</b>
2 1/2"	65	10	05 67 907 MA	<b>07004</b>
3"	80	10	05 67 908 MA	<b>07005</b>
4"	80	10	05 67 910 MA	<b>07420</b>

L	H	E
14	84	52
16	84	52
19	108	62
22	119	70
26	142	84
31	162	94
38	192	117
44	232	148
51	269	179
61	279	179

## UP-S. 67. FT1. MA - PVC-U SPRING CHECK VALVE

**Spring check valve**

- PVC-U body
- NPT female thread
- O-Rings in EPDM

**Válvula anti-retorno**

- Cuerpo en PVC-U
- Roscar hembra NPT
- Anillos tóricos en EPDM

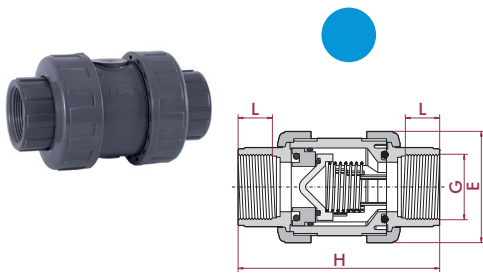

G	DN	PN	REF.	CODE
3/4"	15	16	05 67 800	<b>07421</b>
1/2"	15	16	05 67 801	<b>07006</b>
3/4"	20	16	05 67 802	<b>07007</b>
1"	25	16	05 67 803	<b>07008</b>
1 1/4"	32	16	05 67 804	<b>07009</b>
1 1/2"	40	16	05 67 805	<b>07010</b>
2"	50	16	05 67 806	<b>07011</b>
2 1/2"	65	10	05 67 807	<b>07012</b>
3"	80	10	05 67 808	<b>07013</b>
4"	80	10	05 67 810	<b>07422</b>

L	H	E
14	84	52
16	84	52
19	108	62
22	119	70
26	142	84
31	162	94
38	192	117
44	232	148
51	269	179
61	279	179

### UP-S. 67. SF1. MA - PVC-U SPRING CHECK VALVE COMBO

**Spring check valve**

- PVC-U body
- Female solvent socket
- ASTM series
- O-Rings in EPDM

**Válvula anti-retorno**

- Cuerpo en PVC-U
- Encolar hembra
- Serie ASTM
- Anillos tóricos en EPDM

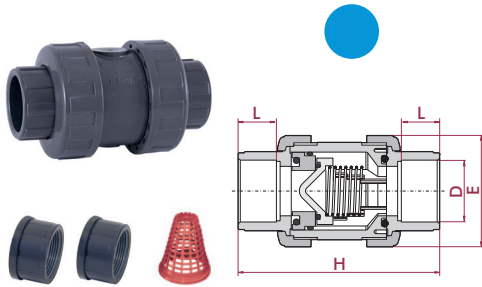

D	DN	PN	REF.	CODE
½"	15	16	05 67 801 D	<b>22015</b>
¾"	20	16	05 67 802 D	<b>22016</b>
1"	25	16	05 67 803 D	<b>22017</b>
1¼"	32	16	05 67 804 D	<b>22018</b>
1½"	40	16	05 67 805 D	<b>22019</b>
2"	50	16	05 67 806 D	<b>22020</b>
2½"	65	10	05 67 907 MAR	<b>22072</b>
3"	80	10	05 67 908 MAR	<b>22076</b>
4"	80	10	05 67 910 MAR	<b>24302</b>

L	H	E
16	84	52
19	108	62
22	119	70
26	142	84
31	162	94
38	192	117
44	232	148
51	269	179
61	279	179

### UP-S. 67. FT1. MA - PVC-U SPRING CHECK VALVE COMBO

**Spring check valve**

- PVC-U body
- NPT female thread
- O-Rings in EPDM

**Válvula anti-retorno**

- Cuerpo en PVC-U
- Roscar hembra NPT
- Anillos tóricos en EPDM

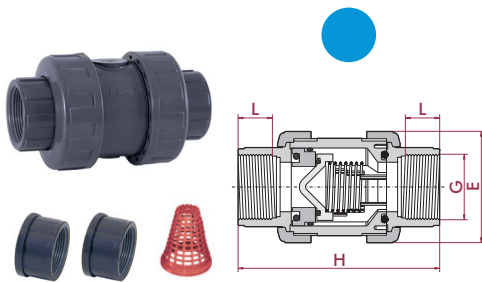

G	DN	PN	REF.	CODE
½"	15	16	05 67 801 D	<b>22015</b>
¾"	20	16	05 67 802 D	<b>22016</b>
1"	25	16	05 67 803 D	<b>22017</b>
1¼"	32	16	05 67 804 D	<b>22018</b>
1½"	40	16	05 67 805 D	<b>22019</b>
2"	50	16	05 67 806 D	<b>22020</b>
2½"	65	10	05 67 807 R	<b>22071</b>
3"	80	10	05 67 808 R	<b>22075</b>
4"	80	10	05 67 810 R	<b>24301</b>

L	H	E
16	84	52
19	108	62
22	119	70
26	142	84
31	162	94
38	192	117
44	232	148
51	269	179
61	279	179

**COMBO VERSION**

- 1½" - 2": valve with solvent socket unions + spare threaded unions in the same box
- 2½" - 4": only solvent socket or threaded unions assembled including the grid for transforming the check valve in foot valve

**VERSIÓN COMBO**

- 1½" - 2": manguitos enlace encolar montados + manguitos enlace roscar añadidos en caja
- 2½" - 4": sólo manguitos enlace encolar o roscar e incluyen rejilla para transformación en válvula de pie

UP-S. **67**. SF4. MA - PVC-U SPRING CHECK VALVE

**Spring check valve**

- PVC-U body
- Female solvent socket
- ASTM series
- O-Rings in FPM

**Válvula anti-retorno**

- Cuerpo en PVC-U
- Encolar hembra
- Serie ASTM
- Anillos tóricos en FPM

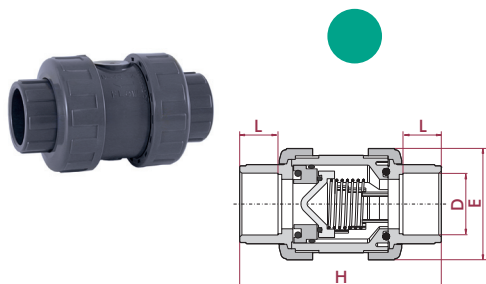

D	DN	PN	REF.	CODE
½"	15	16	05 67 901 AV	<b>10965</b>
¾"	20	16	05 67 902 AV	<b>10966</b>
1"	25	16	05 67 903 AV	<b>10967</b>
1¼"	32	16	05 67 904 AV	<b>10968</b>
1½"	40	16	05 67 905 AV	<b>10969</b>
2"	50	16	05 67 906 AV	<b>10970</b>
2½"	65	10	05 67 907 AV	<b>10971</b>
3"	80	10	05 67 908 AV	<b>10972</b>
4"	80	10	05 67 910 AV	<b>10973</b>

L	H	E
16	84	52
19	108	62
22	119	70
26	142	84
31	162	94
38	192	117
44	232	148
51	269	179
61	279	179

 UP-S. **67**. FT4. MA - PVC-U SPRING CHECK VALVE

**Spring check valve**

- PVC-U body
- NPT female thread
- O-Rings in FPM

**Válvula anti-retorno**

- Cuerpo en PVC-U
- Roscar hembra NPT
- Anillos tóricos en FPM

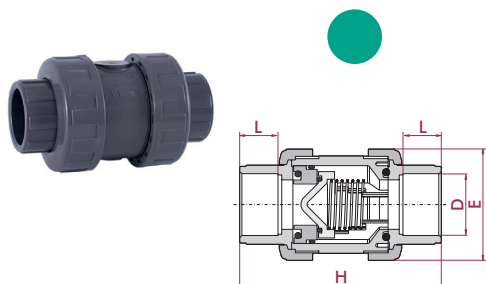

D	DN	PN	REF.	CODE
½"	15	16	05 67 801 VI	<b>10975</b>
¾"	20	16	05 67 802 VI	<b>10976</b>
1"	25	16	05 67 803 VI	<b>10977</b>
1¼"	32	16	05 67 804 VI	<b>10978</b>
1½"	40	16	05 67 805 VI	<b>10979</b>
2"	50	16	05 67 806 VI	<b>10980</b>
2½"	65	10	05 67 807 VI	<b>10981</b>
3"	80	10	05 67 808 VI	<b>10985</b>
4"	80	10	05 67 810 VI	<b>10986</b>

L	H	E
16	84	52
19	108	62
22	119	70
26	142	84
31	162	94
38	192	117
44	232	148
51	269	179
61	279	179

### UP-S. 67. SF4. MA - PVC-U SPRING CHECK VALVE COMBO

**Spring check valve**

- PVC-U body
- Female solvent socket
- ASTM series
- O-Rings in FPM

**Válvula anti-retorno**

- Cuerpo en PVC-U
- Encolar hembra
- Serie ASTM
- Anillos tóricos en FPM

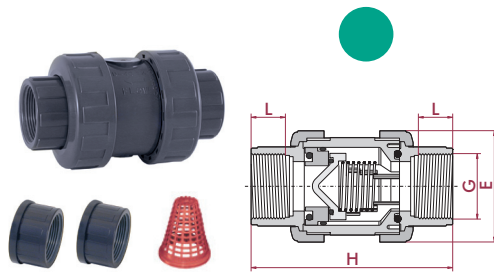

G	DN	PN	REF.	CODE
½"	15	16	05 67 801 VID *	<b>22015VIT</b>
¾"	20	16	05 67 802 VID *	<b>22016VIT</b>
1"	25	16	05 67 803 VID *	<b>22017VIT</b>
1¼"	32	16	05 67 804 VID *	<b>22018VIT</b>
1½"	40	16	05 67 805 VID *	<b>22019VIT</b>
2"	50	16	05 67 806 VID *	<b>22020VIT</b>
2½"	65	10	05 67 807 VIR *	<b>22071VIT</b>
3"	80	10	05 67 808 VIR *	<b>22075VIT</b>
4"	80	10	05 67 810 VIR *	<b>24301VIT</b>

L	H	E
16	84	52
19	108	62
22	119	70
26	142	84
31	162	94
38	192	117
44	232	148
51	269	179
61	279	179

### UP-S. 67. FT4. MA - PVC-U SPRING CHECK VALVE COMBO

**Spring check valve**

- PVC-U body
- NPT female thread
- O-Rings in FPM

**Válvula anti-retorno**

- Cuerpo en PVC-U
- Roscar hembra NPT
- Anillos tóricos en FPM

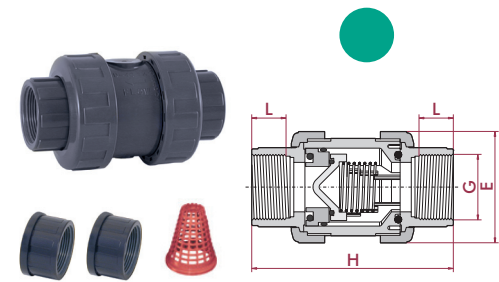

G	DN	PN	REF.	CODE
½"	15	16	05 67 801 VID *	<b>22015VIT</b>
¾"	20	16	05 67 802 VID *	<b>22016VIT</b>
1"	25	16	05 67 803 VID *	<b>22017VIT</b>
1¼"	32	16	05 67 804 VID *	<b>22018VIT</b>
1½"	40	16	05 67 805 VID *	<b>22019VIT</b>
2"	50	16	05 67 806 VID *	<b>22020VIT</b>
2½"	65	10	05 67 807 VIR *	<b>22071VIT</b>
3"	80	10	05 67 808 VIR *	<b>22075VIT</b>
4"	80	10	05 67 810 VIR *	<b>24301VIT</b>

L	H	E
16	84	52
19	108	62
22	119	70
26	142	84
31	162	94
38	192	117
44	232	148
51	269	179
61	279	179

**COMBO VERSION**

- 1½" - 2": valve with solvent socket unions + spare threaded unions in the same box
- 2½" - 4": only solvent socket or threaded unions assembled including the grid for transforming the check valve in foot valve

**VERSIÓN COMBO**

- 1½" - 2": manguitos enlace encolar montados + manguitos enlace rosca añadidos en caja
- 2½" - 4": sólo manguitos enlace encolar o rosca e incluyen rejilla para transformación en válvula de pie

## PVC-U FOOT VALVES - SPRING SERIES

### VÁLVULAS DE PIE PVC-U - SERIE MUELLE



Sizes	Solvent cement D16 - D110 (DN10 - DN100) Threaded 3/8" - 4"	
Standards	Solvent socket - Metric, British standard, ASTM, JIS Threaded - BSP, NPT	EN ISO 1452, EN ISO 15493, BS 4346-1, ASTM D 2467, JIS K 6743 ISO 228-1, ASTM D 2464
Working pressure	@ 20°C (73°F)  D16-D63 (3/8" - 2"): PN 16 (240 psi) D75 - D110 (2 1/2" - 4"): PN 10 (150 psi)	
Minimum working pressure		
Materials	O-rings: EPDM / FPM	
Characteristics	<ul style="list-style-type: none"> <li>• <b>May be used either vertically and horizontally.</b></li> <li>• 100% factory tested.</li> <li>• Easy installation and maintenance.</li> <li>• Available in PVC-U.</li> <li>• Resistance to many inorganic chemicals.</li> <li>• Excellent flow characteristics.</li> </ul>	<ul style="list-style-type: none"> <li>• <b>Se pueden usar indistintamente verticalmente o horizontalmente.</b></li> <li>• Probadas al 100% en fábrica.</li> <li>• Fácil instalación y mantenimiento.</li> <li>• Disponibles en PVC-U.</li> <li>• Resistencia a múltiples sustancias químicas inorgánicas.</li> <li>• Excelentes características de conducción.</li> </ul>
Certifications / regulations	Check valve design regulation - ISO 16137:2006	

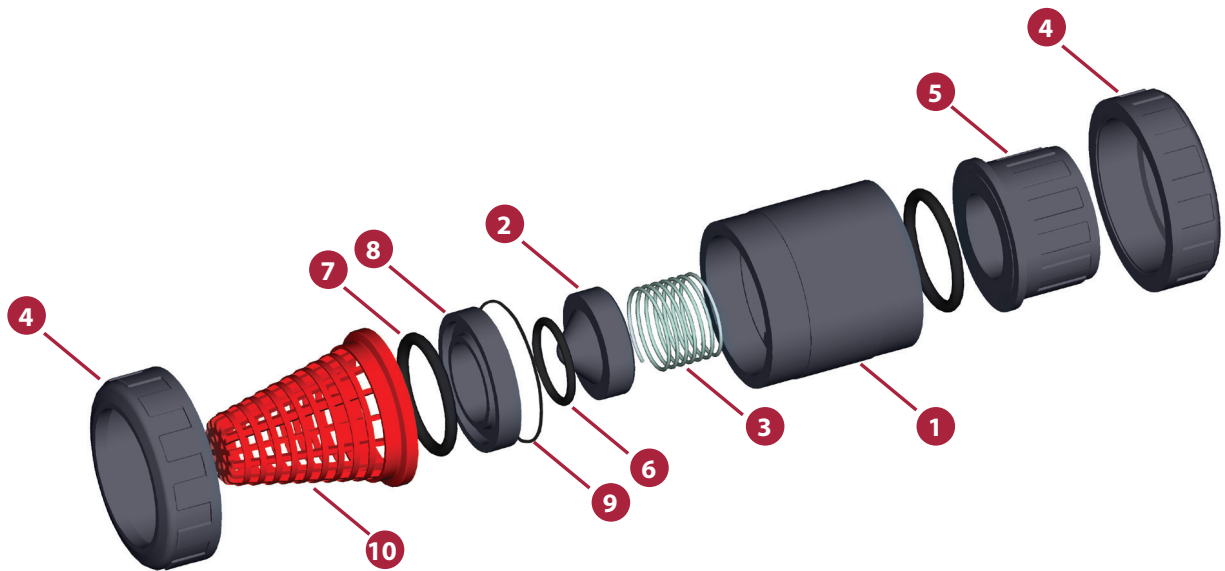
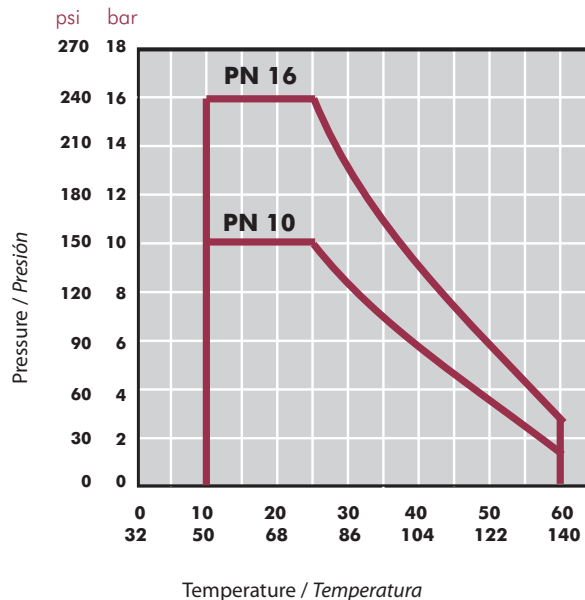

FIG.	Parts	Despiece	Material
1	Body	Cuerpo	PVC-U / PVC-C
2	Cone	Cono de cierre	PVC-U / PVC-C
3	Spring	Muelle	Staniless Steel AISI 302
4	Union nut	Tuerca	PVC-U / PVC-C
5	End connector	Manguito enlace	PVC-U / PVC-C
6	Cone o-ring	Junta cono	EPDM / FPM
7	End connector o-ring	Junta manguito	EPDM / FPM
8	Seal-carrier	Portajuntas	PVC-U / PVC-C
9	Body o-ring	Junta cuerpo	EPDM / FPM
10	Foot valve screen	Rejilla	PP

**PRESSURE / TEMPERATURE GRAPH**  
**DIAGRAMA PRESIÓN / TEMPERATURA**



Life: 25 years  
 Hydrostatic maximum pressure a component may withstand in continuous service (without overpressure)

*Vida útil: 25 años*  
*Presión hidrostática máxima que un componente es capaz de soportar en servicio continuo (sin sobrepresión)*

**PRESSURE LOSS DIAGRAM**
**DIAGRAMA DE PÉRDIDAS DE CARGA**

D16 - 3/8"		D20 - 1/2"		D25 - 3/4"		D32 - 1"		D40 - 1 1/4"		D50 - 1 1/2"		D63 - 2"		D75 - 2 1/2"		D90 - 3"		D110 - 4"	
A	B	A	B	A	B	A	B	A	B	A	B	A	B	A	B	A	B	A	B
0,42	0,34	0,44	0,34	0,54	0,17	0,35	0,13	3,15	0,13	25,85	0,38	39,80	0,70	50,00	0,40	83,50	0,45	77,2	0,46
0,85	0,52	0,92	0,58	1,06	0,22	1,13	0,18	5,20	0,12	20,70	0,27	34,50	0,48	44,20	0,29	74,80	0,39	67,5	0,36
1,35	0,58	1,60	0,19	1,65	0,15	1,62	0,15	7,35	0,16	17,50	0,19	27,50	0,28	36,50	0,23	64,90	0,31	60,1	0,30
2,08	0,28	2,05	0,18	2,18	0,18	2,02	0,14	9,38	0,21	12,30	0,11	21,15	0,17	30,90	0,20	50,38	0,21	49,6	0,22
2,44	0,34	2,48	0,22	3,21	0,29	2,59	0,14	12,17	0,31	8,86	0,09	12,65	0,09	25,50	0,15	43,08	0,18	41,1	0,18
2,80	0,60	3,10	0,30	3,91	0,38	3,07	0,15	15,05	0,43	3,22	0,09	6,25	0,08	20,35	0,12	35,22	0,14	31,5	0,14
-	-	3,53	0,35	4,32	0,44	3,51	0,16	-	-	-	-	-	-	12,30	0,11	28,75	0,11	24,6	0,13
-	-	-	-	-	-	4,20	0,20	-	-	-	-	-	-	6,27	0,11	18,02	0,08	15,8	0,01
-	-	-	-	-	-	-	-	-	-	-	-	-	-	-	-	8,28	0,11	7,9	0,08
-	-	-	-	-	-	-	-	-	-	-	-	-	-	-	-	-	-	-	-

**A =** Flow (m<sup>3</sup>/h)  
Caudal (m<sup>3</sup>/h)

**B =** Pressure loss (bar)  
Pérdida de carga (bar)

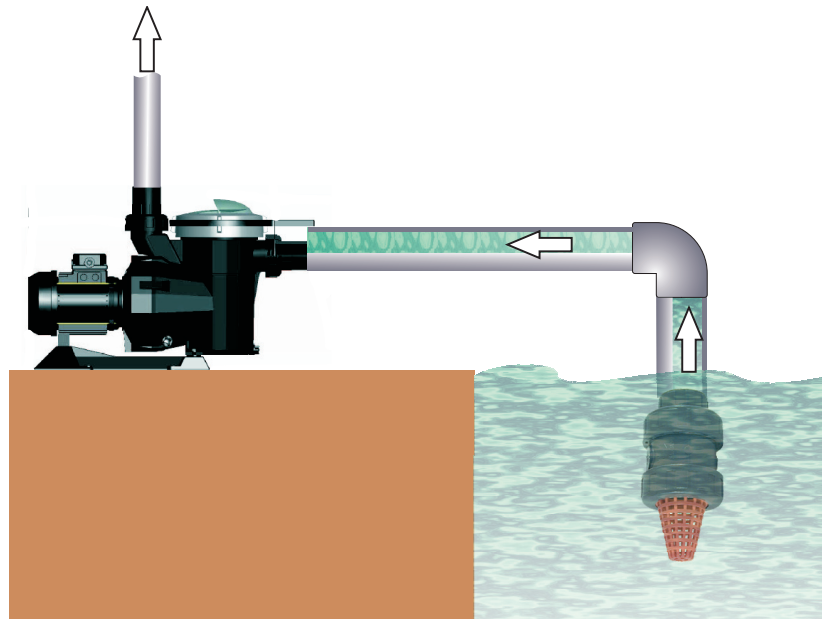
**OPENING PRESSURE**
**PRESIÓN DE APERTURA**

Minimum pressure: opening start  
Maximum pressure: open valve

Minimum pressure: opening start  
Maximum pressure: open valve

D	P (bar) Minimum opening	P (bar) Maximum opening	P (PSI) Minimum opening	P (PSI) Maximum opening
20	0,11	0,19	1,57	2,71
25	0,035	0,067	0,5	0,95
32	0,042	0,077	0,6	1,1
40	0,038	0,069	0,54	0,98
50	0,063	0,088	0,9	1,25
63	0,038	0,060	0,54	0,85
75	0,031	0,060	0,44	0,85
90	0,025	0,060	0,35	0,85



### UP-S. 66. SF1. MA - PVC-U FOOT SPRING CHECK VALVE

**Foot valve**

- PVC-U body
- Female solvent socket
- ASTM series
- O-Rings in EPDM

**Válvula de pie**

- Cuerpo en PVC-U
- Encolar hembra
- Serie ASTM
- Anillos tóricos en EPDM

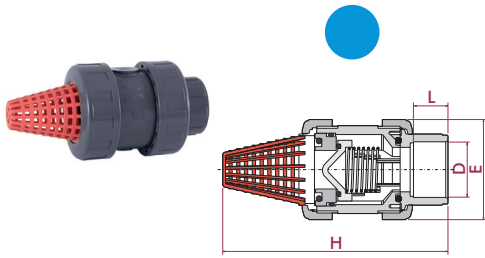

D	DN	PN	REF.	CODE
3/8"	15	16	05 66 900 MA	<b>07423</b>
1/2"	15	16	05 66 901 MA	<b>06982</b>
3/4"	20	16	05 66 902 MA	<b>06983</b>
1"	25	16	05 66 903 MA	<b>06984</b>
1 1/4"	32	16	05 66 904 MA	<b>06985</b>
1 1/2"	40	16	05 66 905 MA	<b>06986</b>
2"	50	16	05 66 906 MA	<b>06987</b>
2 1/2"	65	10	05 66 907 MA	<b>06988</b>
3"	80	10	05 66 908 MA	<b>06989</b>
4"	80	10	05 66 910 MA	<b>07425</b>

L	H	E
14	107	52
16	107	52
19	130	62
22	154	70
26	176	84
31	202	94
38	239	117
44	306	148
51	362	179
61	367	179

### UP-S. 66. FT1. MA - PVC-U FOOT SPRING CHECK VALVE

**Foot valve**

- PVC-U body
- NPT female thread
- O-Rings in EPDM

**Válvula de pie**

- Cuerpo en PVC-U
- Roscar hembra NPT
- Anillos tóricos en EPDM

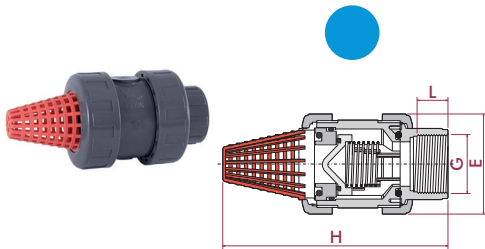

G	DN	PN	REF.	CODE.
3/8"	15	16	05 66 800	<b>07424</b>
1/2"	15	16	05 66 801	<b>06990</b>
3/4"	20	16	05 66 802	<b>06991</b>
1"	25	16	05 66 803	<b>06992</b>
1 1/4"	32	16	05 66 804	<b>06993</b>
1 1/2"	40	16	05 66 805	<b>06994</b>
2"	50	16	05 66 806	<b>06995</b>
2 1/2"	65	10	05 66 807	<b>06996</b>
3"	80	10	05 66 808	<b>06997</b>
4"	80	10	05 66 810	<b>07426</b>

L	H	E
14	107	52
16	107	52
19	130	62
22	154	70
26	176	84
31	202	94
38	239	117
44	306	148
51	362	179
61	367	179

Available with FPM o-rings  
 Disponible con juntas en FPM

## PVC-U CHECK VALVES - BALL SERIES

### VÁLVULAS ANTI-RETORNO PVC-U - SERIE BOLA



Sizes	Solvent cement D20 - D110 (DN15 - DN100) Threaded ½" - 4"	
Standards	Solvent socket - Metric, British standard, ASTM, JIS Threaded - BSP, NPT	EN ISO 1452, EN ISO 15493, BS 4346-1, ASTM D 2467, JIS K 6743 ISO 228-1, ASTM D 2464
Working pressure	@ 20°C (73°F)  D20-D63 (½" - 2"): PN 16 (240 psi) D75 - D110 (2½" - 4"): PN 10 (150 psi)	
Minimum return pressure	<b>0,2 bar (3 psi)</b> <b>Minimal downstream pressure to keep the valve closed in horizontal position.</b> <b>Presión mínima aguas abajo para mantener la válvula cerrada en caso de instalación horizontal.</b>	
Materials	O-rings: EPDM / FPM	
Characteristics	<ul style="list-style-type: none"> <li>• <b>Completely made in plastic - corrosion free.</b></li> <li>• 100% factory tested.</li> <li>• Excellent flow rate.</li> <li>• Easy installation and maintenance.</li> <li>• May be used either vertically and horizontally.</li> <li>• Available in PVC-U and Corzan® PVC-C.</li> <li>• Resistance to many inorganic chemicals.</li> <li>• Excellent flow characteristics.</li> </ul>	<ul style="list-style-type: none"> <li>• <b>Fabricada completamente en plástico - libre de corrosión.</b></li> <li>• Probadas al 100% en fábrica.</li> <li>• Excelente coeficiente de caudal.</li> <li>• Fácil instalación y mantenimiento.</li> <li>• Se pueden usar indistintamente verticalmente o horizontalmente.</li> <li>• Disponibles en PVC-U y Corzan® PVC-C.</li> <li>• Resistencia a múltiples sustancias químicas inorgánicas.</li> <li>• Excelentes características de conducción.</li> </ul>
Certifications / regulations	Check valve design regulation - ISO 16137:2006	

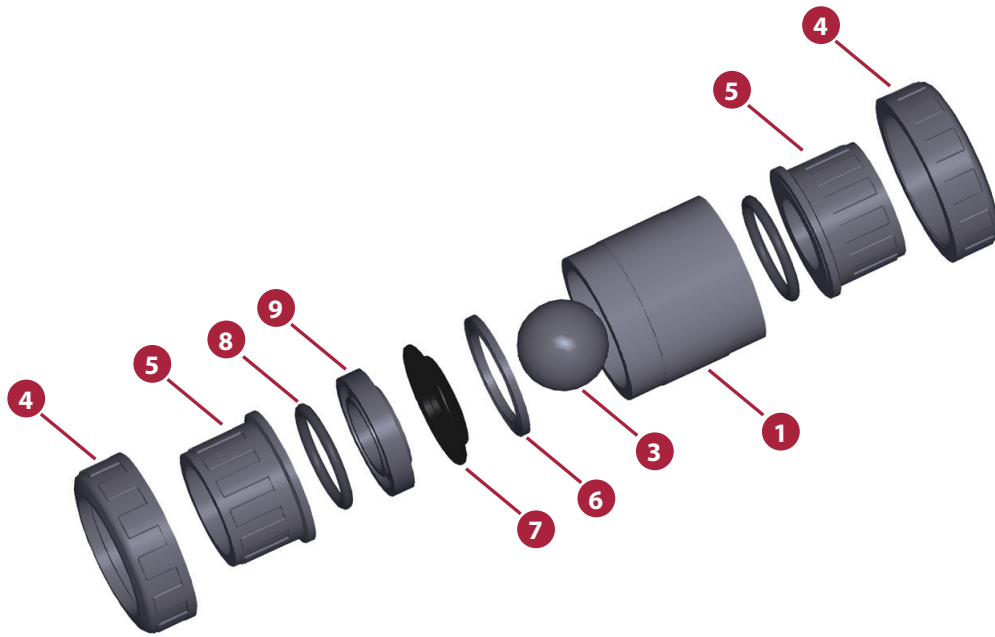
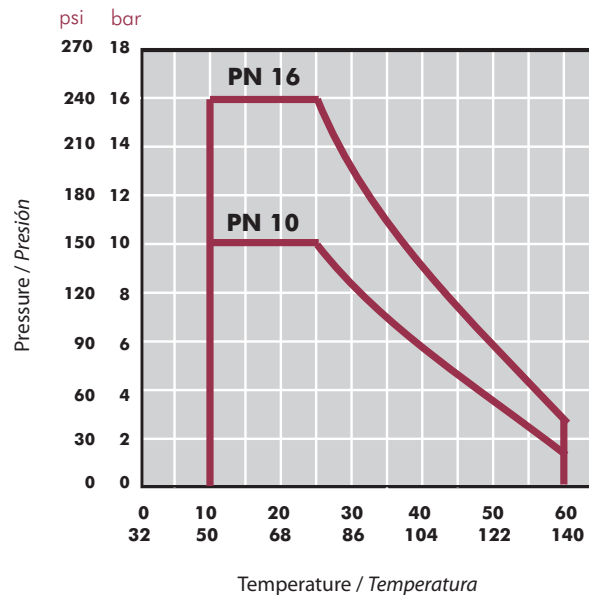

FIG.	Parts	Despiece	Material
1	Body	Cuerpo	PVC-U
3	Ball	Bola	PVC-U
4	Union nut	Tuerca	PVC-U
5	End connector	Manguito enlace	PVC-U
6	Closing ring	Anillo de cierre	PVC-U
7	Body o-ring	Junta cuerpo	EPDM / FPM
8	End connector o-ring	Junta manguito	EPDM / FPM
9	Seal-carrier	Portajuntas	PVC-U

**PRESSURE / TEMPERATURE GRAPH**  
**DIAGRAMA PRESIÓN / TEMPERATURA**



Life: 25 years  
 Hydrostatic maximum pressure a component may withstand in continuous service (without overpressure)

Vida útil: 25 años  
 Presión hidrostática máxima que un componente es capaz de soportar en servicio continuo (sin sobrepresión)

**PRESSURE LOSS DIAGRAM**  
**DIAGRAMA DE PÉRDIDAS DE CARGA**

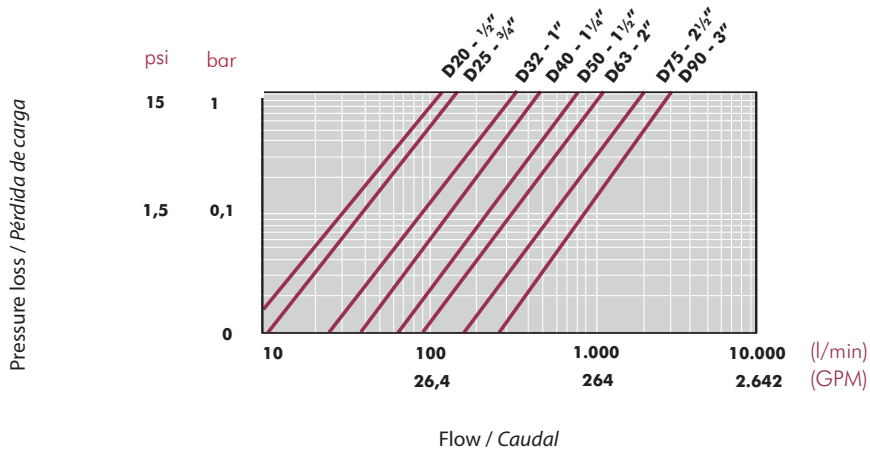

**RELATIVE FLOW**  
**FLUJO RELATIVO**

D	20-1/2"	25-3/4"	32-1"	40-1 1/4"	50-1 1/2"	63-2"	75-2 1/2"	90-3"
DN	15	20	25	32	40	50	65	80
$Kv_{100}$	99	128	308	453	795	1040	1932	2754
Cv	7	9	22	32	56	73	135	193

$Cv = Kv_{100} / 14,28$   
 $Kv_{100}$  (l/min,  $\Delta p = 1$  bar)  
 $Cv$  (GPM,  $\Delta p = 1$  psi)

**Open**  
**Abierto**

**Closed**  
**Cerrado**

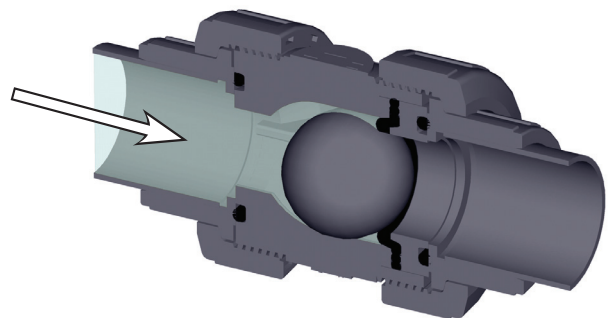
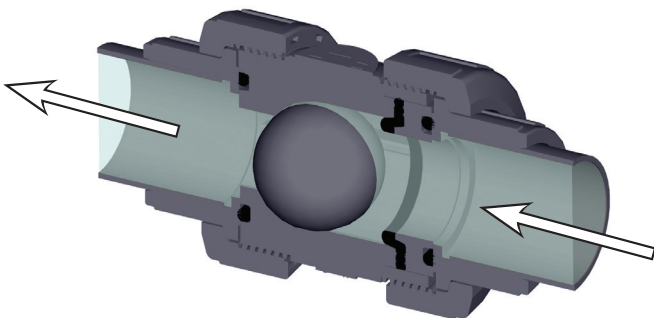

### ASSEMBLY INSTRUCTIONS

#### Solvent socket or threaded unions

Loosen the valve union nuts (4) and separate these and the end connectors (5) from the valve body. Pass the pipe through the nuts and then place the bushes over the end of the pipe. The socket unions should be glued onto the pipe using a PVC-U or PVC-C adhesive and pressure should not be applied to the system until a drying period of at least 1 hour per bar of working pressure has elapsed. In the case of threaded unions, PTFE tape should be applied to the male threads. The pipes can now be attached to the valve by hand tightening down the nuts.

### INSTRUCCIONES DE MONTAJE

#### Uniones encoladas o roscadas

Afloje las tuercas (4) de la válvula y sepárelas de los manguitos (5). Introduzca las tuercas en los tubos y a continuación fije los manguitos en los extremos del tubo. Las uniones encoladas se realizarán con un adhesivo para tubos de PVC-U o PVC-C rígido y no se aplicará presión hasta transcurridas al menos 1 hora por bar. En las uniones roscadas se colocará cinta de PTFE en las roscas macho. A continuación ya podrá colocarse la válvula entre los manguitos y apretar a mano las tuercas sobre la válvula.

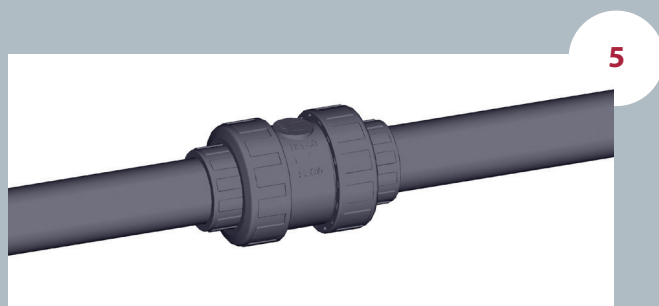
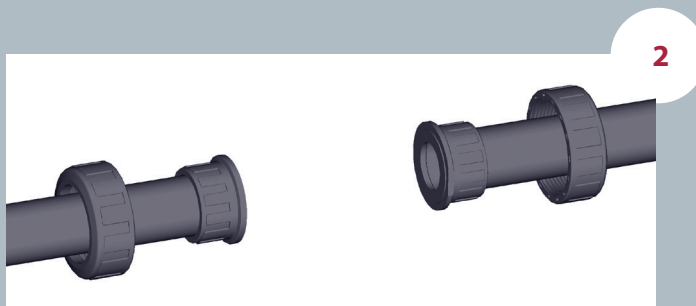
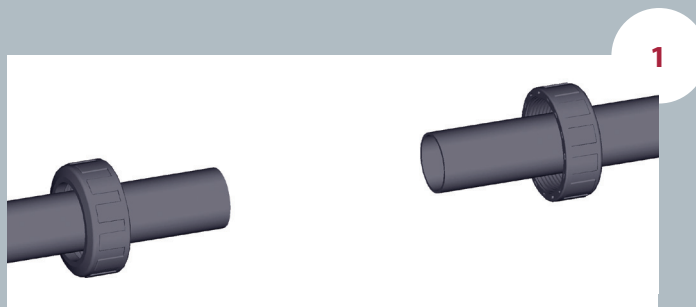

## UP-B. 67. SF1. MA - PVC-U BALL CHECK VALVE

**Ball check valve**

- PVC-U body
- Female solvent socket
- ASTM series
- O-rings in EPDM

**Válvula anti-retorno de bola**

- Cuerpo en PVC-U
- Encolar hembra
- Serie ASTM
- Anillos tóricos en EPDM

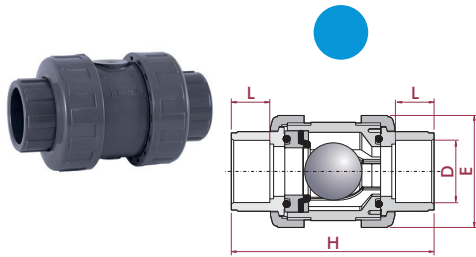

D	DN	PN	REF.	CODE
½"	15	16	05 67 901 EMA	<b>41380</b>
¾"	20	16	05 67 902 EMA	<b>41381</b>
1"	25	16	05 67 903 EMA	<b>41382</b>
1¼"	32	16	05 67 904 EMA	<b>41383</b>
1½"	40	16	05 67 905 EMA	<b>41384</b>
2"	50	16	05 67 906 EMA	<b>41385</b>
2½"	65	10	05 67 907 EMA	<b>41386</b>
3"	80	10	05 67 908 EMA	<b>41387</b>
4"	80	10	05 67 910 EMA	<b>41388</b>

L	H	E
16	84	52
19	108	62
22	119	70
26	142	84
31	162	94
38	192	117
44	232	148
51	269	179
51	269	179

## UP-B. 67. FT1. MA - PVC-U BALL CHECK VALVE

**Ball check valve**

- PVC-U body
- NPT female thread
- O-Rings in EPDM

**Válvula anti-retorno de bola**

- Cuerpo en PVC-U
- Roscar hembra NPT
- Anillos tóricos en EPDM

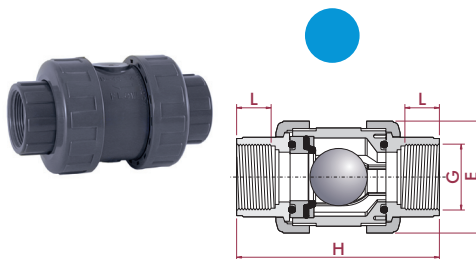

G	DN	PN	REF.	CODE
½"	15	16	05 67 801 E	<b>41389</b>
¾"	20	16	05 67 802 E	<b>41390</b>
1"	25	16	05 67 803 E	<b>41391</b>
1¼"	32	16	05 67 804 E	<b>41392</b>
1½"	40	16	05 67 805 E	<b>41393</b>
2"	50	16	05 67 806 E	<b>41394</b>
2½"	65	10	05 67 807 E	<b>41395</b>
3"	80	10	05 67 808 E	<b>41396</b>
4"	80	10	05 67 810 E	<b>41397</b>

L	H	E
16	84	52
19	108	62
22	119	70
26	142	84
31	167	94
38	192	117
44	232	148
51	269	179
61	279	179

UP-B. **67**. SF1. MA - PVC-U BALL CHECK VALVE COMBO

**Ball check valve**

- PVC-U body
- Female solvent socket
- ASTM series
- O-rings in EPDM

**Válvula anti-retorno de bola**

- Cuerpo en PVC-U
- Encolar hembra
- Serie ASTM
- Anillos tóricos en EPDM

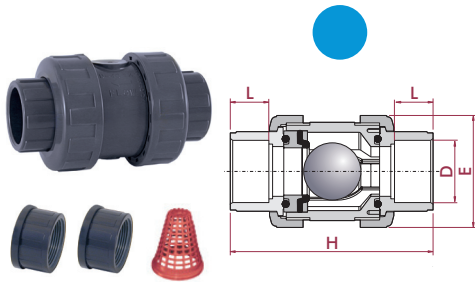

D	DN	PN	REF.	CODE
½"	15	16	05 67 801 ED *	<b>27360</b>
¾"	20	16	05 67 802 ED *	<b>27361</b>
1"	25	16	05 67 803 ED *	<b>27362</b>
1¼"	32	16	05 67 804 ED *	<b>27363</b>
1½"	40	16	05 67 805 ED *	<b>27000</b>
2"	50	16	05 67 806 ED *	<b>27001</b>
2½"	65	10	05 67 907 EMAR *	<b>27374</b>
3"	80	10	05 67 908 EMAR *	<b>27375</b>
4"	80	10	05 67 910 EMAR *	<b>27376</b>

L	H	E
16	84	52
19	108	62
22	119	70
26	142	84
31	162	94
38	192	117
44	232	148
51	269	179
51	269	179

UP-B. **67**. FT1. MA - PVC-U BALL CHECK VALVE COMBO

**Ball check valve**

- PVC-U body
- NPT female thread
- O-Rings in EPDM

**Válvula anti-retorno de bola**

- Cuerpo en PVC-U
- Roscar hembra NPT
- Anillos tóricos en EPDM

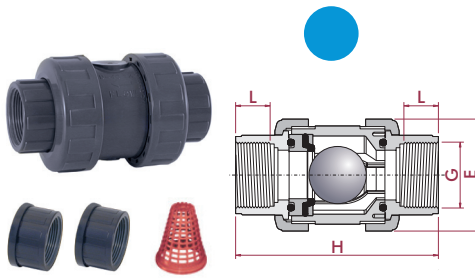

G	DN	PN	REF.	CODE
½"	15	16	05 67 801 ED *	<b>27360</b>
¾"	20	16	05 67 802 ED *	<b>27361</b>
1"	25	16	05 67 803 ED *	<b>27362</b>
1¼"	32	16	05 67 804 ED *	<b>27363</b>
1½"	40	16	05 67 805 ED *	<b>27000</b>
2"	50	16	05 67 806 ED *	<b>27001</b>
2½"	65	10	05 67 807 ER *	<b>27368</b>
3"	80	10	05 67 808 ER *	<b>27369</b>
4"	80	10	05 67 810 ER *	<b>27370</b>

L	H	E
16	84	52
19	108	62
22	119	70
26	142	84
31	167	94
38	192	117
44	232	148
51	269	179
61	279	179

COMBO VERSION

- 1½" - 2": valve with solvent socket unions + spare threaded unions in the same box
- 2½" - 4": only solvent sokcet or threaded unions assembled including the grid for transforming the check valve in foot valve

VERSIÓN COMBO

- 1½" - 2": manguitos enlace encolar montados + manguitos enlace roscar añadidos en caja
- 2½" - 4": sólo manguitos enlace encolar o roscar e incluyen rejilla para transformación en válvula de pie

## UP-B. 67. SF4. MA - PVC-U BALL CHECK VALVE

**Ball check valve**

- PVC-U body
- Female solvent socket
- ASTM series
- O-Rings in FPM

**Válvula anti-retorno de bola**

- Cuerpo en PVC-U
- Encolar hembra
- Serie ASTM
- Anillos tóricos en FPM

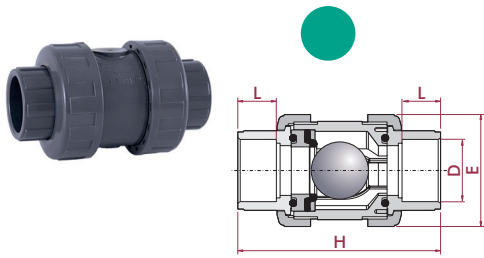

D	DN	PN	REF.	CODE
½"	15	16	05 67 901 VEMA	<b>41962</b>
¾"	20	16	05 67 902 VEMA	<b>41963</b>
1"	25	16	05 67 903 VEMA	<b>41964</b>
1¼"	32	16	05 67 904 VEMA	<b>41965</b>
1½"	40	16	05 67 905 VEMA	<b>41966</b>
2"	50	16	05 67 906 VEMA	<b>41967</b>
2½"	65	10	05 67 907 VEMA	<b>41968</b>
3"	80	10	05 67 908 VEMA	<b>41969</b>
4"	80	10	05 67 910 VEMA	<b>41970</b>

L	H	E
16	84	52
19	108	62
22	119	70
26	142	84
31	162	94
38	192	117
44	232	148
51	269	179
51	269	179

## UP-B. 67. SF4. MA - PVC-U BALL CHECK VALVE COMBO

**Ball check valve**

- PVC-U body
- Female solvent socket
- ASTM series
- O-Rings in FPM

**Válvula anti-retorno de bola**

- Cuerpo en PVC-U
- Encolar hembra
- Serie ASTM
- Anillos tóricos en FPM

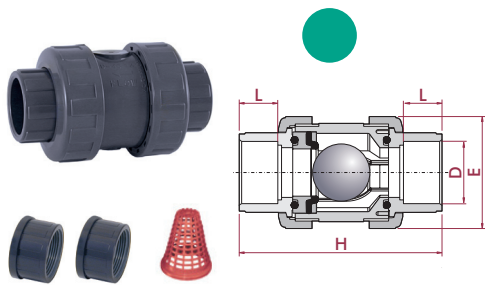

D	DN	PN	REF.	CODE
½"	15	16	05 67 801 VED *	<b>27364</b>
¾"	20	16	05 67 802 VED *	<b>27365</b>
1"	25	16	05 67 803 VED *	<b>27366</b>
1¼"	32	16	05 67 804 VED *	<b>27367</b>
1½"	40	16	05 67 805 VED *	<b>27002</b>
2"	50	16	05 67 806 VED *	<b>27003</b>
2½"	65	10	05 67 907 VEMAR *	<b>27377</b>
3"	80	10	05 67 908 VEMAR *	<b>27378</b>
4"	80	10	05 67 910 VEMAR *	<b>27379</b>

L	H	E
16	84	52
19	108	62
22	119	70
26	142	84
31	162	94
38	192	117
44	232	148
51	269	179
51	269	179

## UP-B. 67. FT4. MA - PVC-U BALL CHECK VALVE COMBO

**Ball check valve**

- PVC-U body
- NPT female thread
- O-Rings in FPM

**Válvula anti-retorno de bola**

- Cuerpo en PVC-U
- Roscar hembra NPT
- Anillos tóricos en FPM

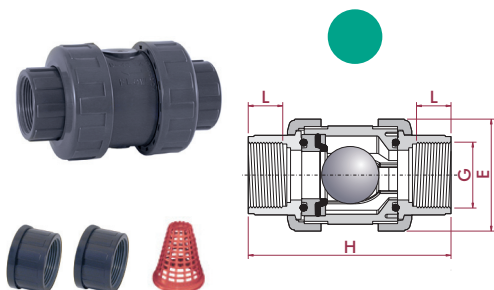

G	DN	PN	REF.	CODE
½"	15	16	05 67 801 VED *	<b>27364</b>
¾"	20	16	05 67 802 VED *	<b>27365</b>
1"	25	16	05 67 803 VED *	<b>27366</b>
1¼"	32	16	05 67 804 VED *	<b>27367</b>
1½"	40	16	05 67 805 VED *	<b>27002</b>
2"	50	16	05 67 806 VED *	<b>27003</b>
2½"	65	10	05 67 807 VER *	<b>27371</b>
3"	80	10	05 67 808 VER *	<b>27372</b>
4"	80	10	05 67 810 VER *	<b>27373</b>

L	H	E
16	84	52
19	108	62
22	119	70
26	142	84
31	167	94
38	192	117
44	232	148
51	269	179
61	279	179

**COMBO VERSION**

- 1½" - 2": valve with solvent socket unions + spare threaded unions in the same box
- 2½" - 4": only solvent sokcet or threaded unions assembled including the grid for transforming the check valve in foot valve

**VERSIÓN COMBO**

- 1½" - 2": manguitos enlace encolar montados + manguitos enlace roscar añadidos en caja
- 2½" - 4": sólo manguitos enlace encolar o roscar e incluyen rejilla para transformación en válvula de pie



## PVC-U FOOT VALVES - BALL SERIES

### VÁLVULAS DE PIE PVC-U - SERIE BOLA



Sizes	Solvent cement D20 - D110 (DN15 - DN100) Threaded ½" - 4"	
Standards	Solvent socket - Metric, British standard, ASTM, JIS Threaded - BSP, NPT	EN ISO 1452, EN ISO 15493, BS 4346-1, ASTM D 2467, JIS K 6743 ISO 228-1, ASTM D 2464
Working pressure	@ 20°C (73°F)  D20-D63 (¾" - 2"): PN 16 (240 psi) D75 - D110 (2½" - 4"): PN 10 (150 psi)	
Minimum return pressure	<b>0,2 bar (3 psi)</b> <b>Minimal downstream pressure to keep the valve closed in horizontal position.</b> <b>Presión mínima aguas abajo para mantener la válvula cerrada en caso de instalación horizontal.</b>	
Materials	O-rings: EPDM / FPM	
Characteristics	<ul style="list-style-type: none"> <li>• <b>Completely made in plastic - corrosion free.</b></li> <li>• 100% factory tested.</li> <li>• Easy installation and maintenance.</li> <li>• May be used either vertically and horizontally.</li> <li>• Available in PVC-U.</li> <li>• Resistance to many inorganic chemicals.</li> <li>• Excellent flow characteristics.</li> </ul>	<ul style="list-style-type: none"> <li>• <b>Fabricada completamente en plástico - libre de corrosión</b></li> <li>• Probadas al 100% en fábrica.</li> <li>• Fácil instalación y mantenimiento.</li> <li>• Se pueden usar indistintamente verticalmente o horizontalmente.</li> <li>• Disponibles en PVC-U.</li> <li>• Resistencia a múltiples sustancias químicas inorgánicas.</li> <li>• Excelentes características de conducción.</li> </ul>
Certifications / regulations	Check valve design regulation - ISO 16137:2006	

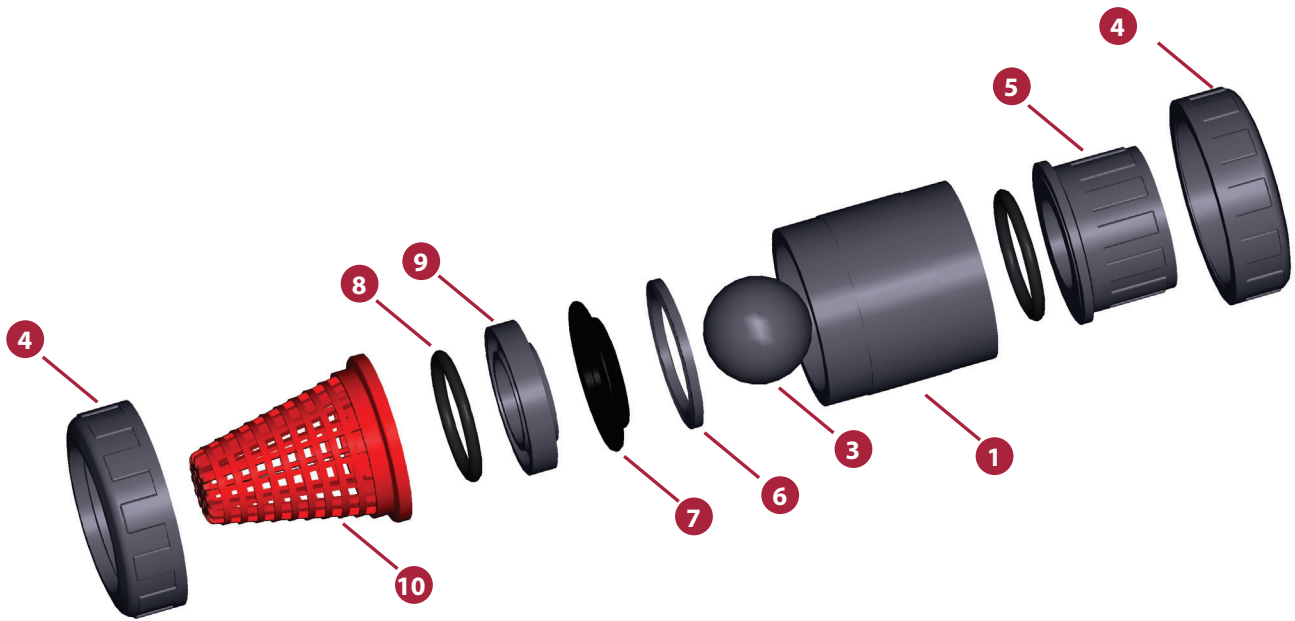
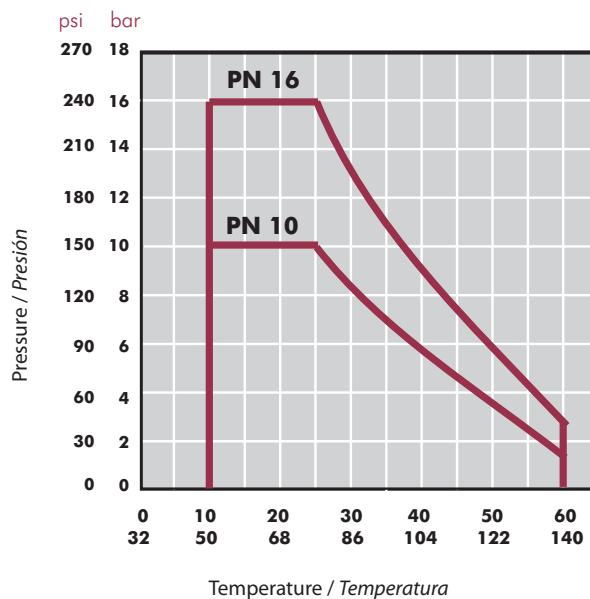

FIG.	Parts	Despiece	Material
1	Body	Cuerpo	PVC-U
3	Ball	Bola	PVC-U
4	Union nut	Tuerca	PVC-U
5	End connector	Manguito enlace	PVC-U
6	Closing ring	Anillo de cierre	PVC-U
7	Body o-ring	Junta cuerpo	EPDM / FPM
8	End connector o-ring	Junta manguito	EPDM / FPM
9	Seal-carrier	Portajuntas	PVC-U
10	Foot valve screen	Rejilla	PP

**PRESSURE / TEMPERATURE GRAPH**  
**DIAGRAMA PRESIÓN / TEMPERATURA**



Life: 25 years  
Hydrostatic maximum pressure a component may withstand in continuous service (without overpressure)

Vida útil: 25 años  
Presión hidrostática máxima que un componente es capaz de soportar en servicio continuo (sin sobrepresión)

**PRESSURE LOSS DIAGRAM**  
**DIAGRAMA DE PÉRDIDAS DE CARGA**

D20 - 1/2"		D25 - 3/4"		D32 - 1"		D40 - 1 1/4"		D50 - 1 1/2"		D63 - 2"		D75 - 2 1/2"		D90 - 3"	
A	B	A	B	A	B	A	B	A	B	A	B	A	B	A	B
1,65	0,13	1,47	0,05	4,36	0,08	4,87	0,15	6,41	0,002	12,53	0,05	12,32	0,05	7,13	0,009
2,33	0,24	2,01	0,054	4,89	0,11	6,21	0,17	11,3	0,02	14,9	0,07	14,95	0,06	15,91	0,04
3,34	0,44	2,34	0,09	5,44	0,15	7,52	0,21	18,76	0,16	17,12	0,11	19,53	0,11	28,58	0,13
3,85	0,52	2,95	0,18	5,89	0,21	10,61	0,27	25,05	0,34	21,7	0,16	25	0,17	37,22	0,22
4,52	0,69	3,6	0,29	7,01	0,26	12,53	0,34	28,44	0,41	27,36	0,28	32,6	0,28	45,61	0,53
-	-	4,03	0,36	9,23	0,39	15,23	0,4	-	-	32,02	0,37	41,43	0,55	58,5	0,64
-	-	4,21	0,38	-	-	-	-	-	-	37,68	0,43	-	-	-	-

**A =** Flow (m<sup>3</sup>/h)  
 Caudal (m<sup>3</sup>/h)

**B =** Pressure loss (bar)  
 Pérdida de carga (bar)

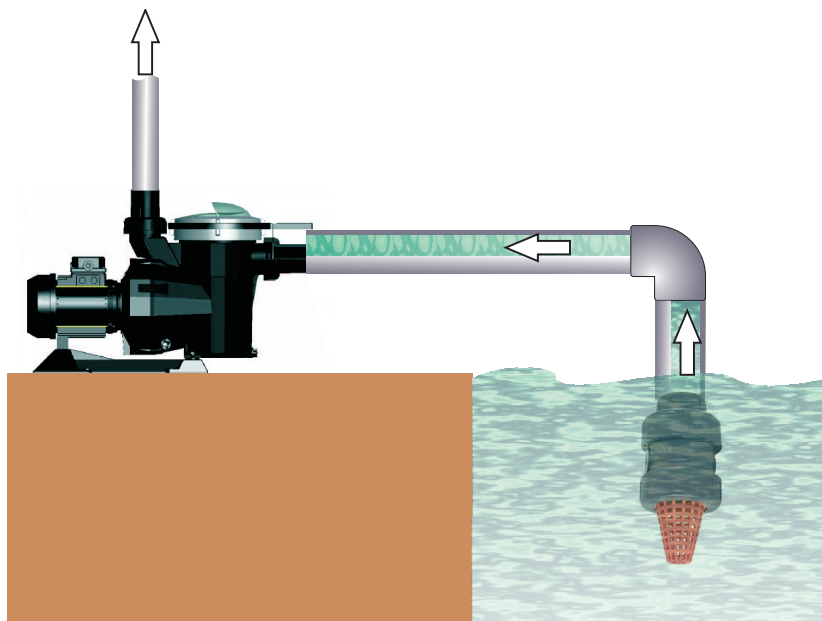

**UP-B. 66. SF1. MA - BALL FOOT CHECK VALVES**
**Ball foot valve**

- PVC-U body
- Female solvent socket
- ASTM series
- O-Rings in EPDM

**Válvula de pie de bola**

- Cuerpo en PVC-U
- Encolar hembra
- Serie ASTM
- Anillos tóricos en EPDM

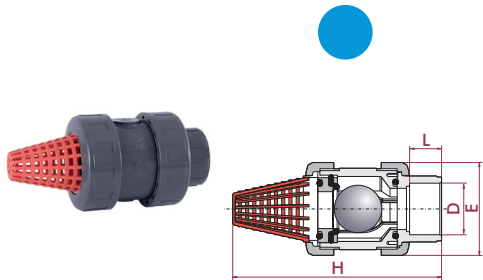

D	DN	PN	REF.	CODE
20	15	16	05 66 901 EMA	<b>41398</b>
25	20	16	05 66 902 EMA	<b>41399</b>
32	25	16	05 66 903 EMA	<b>41400</b>
40	32	16	05 66 904 EMA	<b>41401</b>
50	40	16	05 66 905 EMA	<b>41402</b>
63	50	16	05 66 906 EMA	<b>41403</b>
75	65	10	05 66 907 EMA	<b>41404</b>
90	80	10	05 66 908 EMA	<b>41405</b>
110	80	10	05 66 910 EMA	<b>41406</b>

L	H	E
16	107	52
19	130	62
22	154	70
26	176	84
31	202	94
38	239	117
44	306	148
51	362	179
61	367	179

**UP-B. 66. FT1. MA - BALL FOOT CHECK VALVES**
**Ball foot valve**

- PVC-U body
- NPT female thread
- O-Rings in EPDM

**Válvula de pie de bola**

- Cuerpo en PVC-U
- Roscar hembra NPT
- Anillos tóricos en EPDM

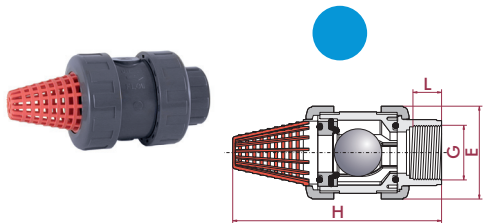

G	DN	PN	REF.	CODE
½"	15	16	05 66 801 E	<b>41407</b>
¾"	20	16	05 66 802 E	<b>41408</b>
1"	25	16	05 66 803 E	<b>41409</b>
1¼"	32	16	05 66 804 E	<b>41410</b>
1½"	40	16	05 66 805 E	<b>41411</b>
2"	50	16	05 66 806 E	<b>41412</b>
2½"	65	10	05 66 807 E	<b>41413</b>
3"	80	10	05 66 808 E	<b>41414</b>
4"	80	10	05 66 810 E	<b>41415</b>

L	H	E
16	107	52
19	130	62
22	154	70
26	176	84
31	202	94
38	239	117
44	306	148
51	362	179
61	367	179

## PVC-U SWING CHECK VALVES

### VÁLVULAS DE CLAPETA PVC-U



Sizes	Metric flanges D63 - D315 (DN50 - DN300) ASTM flanges 4" - 12"	
Standards	ISO/DIN ASTM - 4" - 12"	EN 558-1 ANSI B.16.5 cl. 150
Working pressure	@ 20°C (73°F) D63 - D315 (2" - 12"): PN 6 (90 psi)	
Minimum return pressure	<b>0,1 - 0,3 bar</b> <b>Minimal downstream pressure to keep the valve closed, depending on installation conditions.</b> <b>Presión mínima aguas abajo para mantener la válvula cerrada, dependiendo de las condiciones de instalación.</b>	
Materials	O-rings: EPDM / FPM	
Characteristics	<ul style="list-style-type: none"> <li>• <b>Requires little space in piping systems.</b></li> <li>• <b>Easy installation: wafer body slips between standard flanges. No gaskets required.</b></li> <li>• Vertical and horizontal operation.</li> <li>• Excellent flow characteristics.</li> </ul> <p>Do not install the valve at a distance lower than 5 x D of the pump out. Install with pipe DIN PN 10. In case of PN 16, the valve could be damaged.</p>	<ul style="list-style-type: none"> <li>• <b>Requiere poco espacio en la instalación.</b></li> <li>• <b>Fácil instalación: se monta entre bridas standard. Sin necesidad de juntas adicionales.</b></li> <li>• Instalación vertical y horizontal.</li> <li>• Excelentes características de conducción.</li> </ul> <p>No montar la válvula a una distancia inferior a 5 x D de la salida de una bomba. Montar con tubo PN 10. En caso de usar un PN 16 se podrían ocasionar daños en la válvula.</p>
Certifications / regulations	Check valve design regulation - ISO 16137:2006	

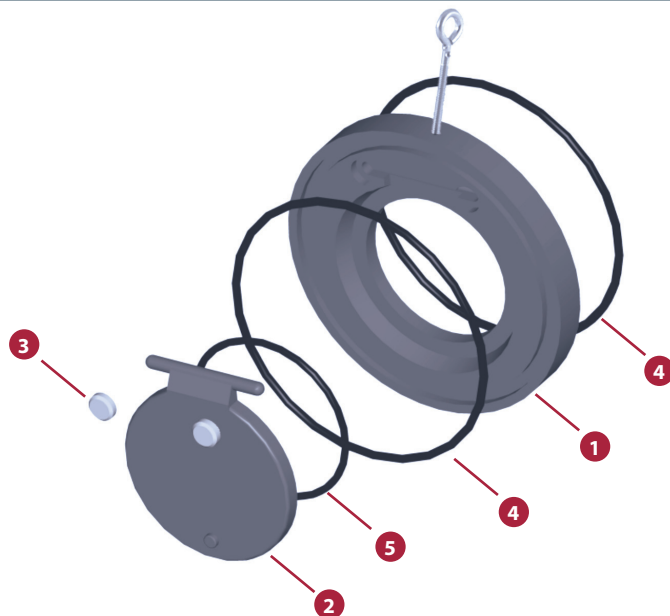
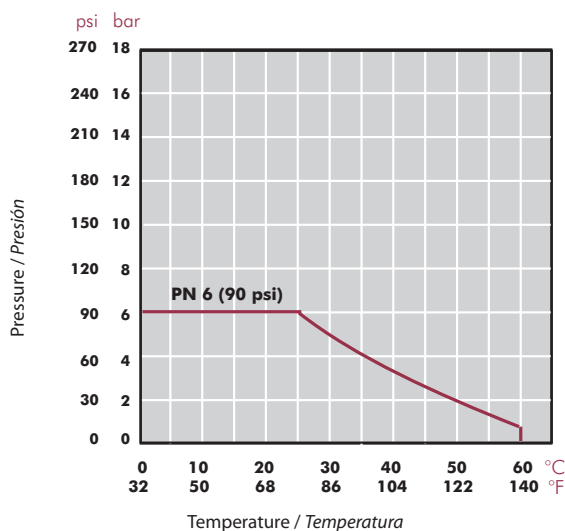

FIG.	Parts	Despiece	Material
1	Body	Cuerpo	PVC-U
2	Flap	Clapeta	PVC-U
3	Cap	Tapón	PP
4	Body O-ring	Junta cuerpo	EPDM / FPM
5	Flap O-ring	Junta clapeta	EPDM / FPM

**PRESSURE / TEMPERATURE GRAPH**  
**DIAGRAMA PRESIÓN / TEMPERATURA**



Life: 25 years  
 Hydrostatic maximum pressure a component may withstand in continuous service (without overpressure)

*Vida útil: 25 años*  
*Presión hidrostática máxima que un componente es capaz de soportar en servicio continuo (sin sobrepresión)*

**PRESSURE LOSS DIAGRAM**

**DIAGRAMA DE PÉRDIDAS DE CARGA**

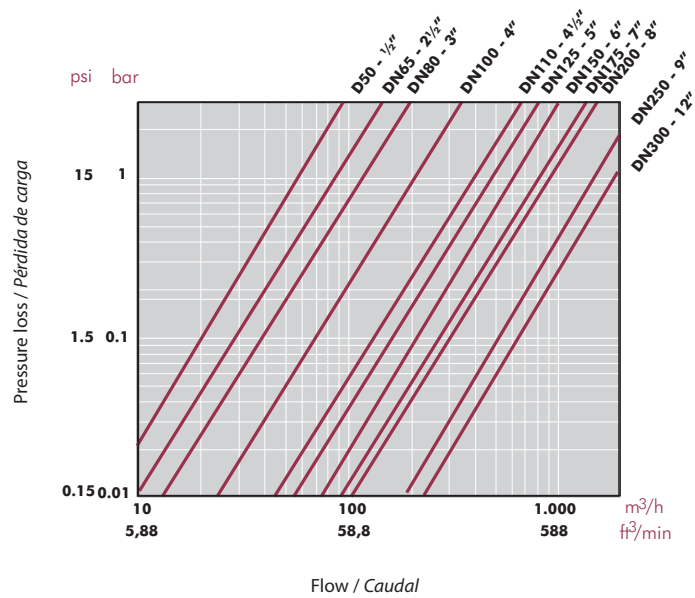

**RELATIVE FLOW**  
**FLUJO RELATIVO**

D	63	75	90	110	125	140	160	200	225	250	280	315
DN	50	65	80	100	125	125	150	175	200	250	250	300
Kv <sub>100</sub>	57	85	130	200	390	480	600	800	900	1.600	1.600	1.850
Cv	4,0	6,0	9,1	14,0	27,3	33,6	42,0	56,0	63,0	112,0	112,0	129,6

$Cv = Kv_{100} / 14,28$   
Kv<sub>100</sub> (l/min, Δp = 1 bar)  
Cv (GPM, Δp = 1 psi)

**UP. 65 - SWING CHECK VALVE**

**Swing check valve**

- PVC-U body
- O-rings in EPDM (FPM upon request)

**Válvula de clapeta**

- Cuerpo en PVC-U
- Anillos tóricos en EPDM (FPM bajo pedido)

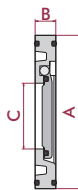
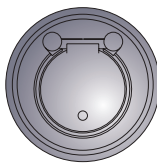

D	DN	PN	REF.	CODE
4"	100	6	05 65 110	<b>08986</b>
5"	125	6	05 65 140	<b>08987</b>
6"	150	6	05 65 160	<b>08988</b>
7"	175	6	05 65 200	<b>09041</b>
8"	200	6	05 65 225	<b>08989</b>
9"	250	6	05 65 250	<b>37056</b>
10"	250	6	05 65 280	<b>41865</b>
12"	300	6	05 65 315	<b>37057</b>

A	B	C
164	22	70
195	23	92
220	25	112
247	28	139
275	35	150
328	40	162
330	40	189
380	45	226

**UP. 65. VKIT - SWING CHECK VALVE KIT**

**Swing check valve with mounting kit**

- PVC-U body
- O-rings in EPDM
- Loose flanges

**Válvula de clapeta con kit accesorios**

- Cuerpo en PVC-U
- Anillos tóricos en EPDM
- Bridas locas

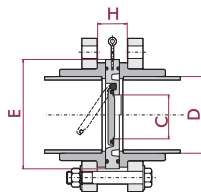

D	DN	PN	REF.	CODE
3"	80	6		<b>61287</b>
4"	100	6		<b>61288</b>
6"	150	6		<b>61290</b>
8"	175	6		<b>67221</b>

C	H	E
52	30	144
70	32	164
112	37	220
139	40	247

## PVC-C CHECK VALVES - SPRING SERIES

### VÁLVULAS ANTI-RETORNO PVC-C - SERIE MUELLE



Sizes	Solvent cement D16 - D110 (DN10 - DN100) Threaded 3/8" - 4"	
Standards	Solvent socket - Metric, British standard, ASTM, JIS Threaded - BSP, NPT	EN ISO 1452, EN ISO 15493, BS 4346-1, ASTM D 2467, JIS K 6743 ISO 228-1, ASTM D 2464
Working pressure	@ 20°C (73°F)  D16-D63 (3/8" - 2"): PN 16 (240 psi) D75 - D110 (2 1/2" - 4"): PN 10 (150 psi)	
Minimum working pressure		
Materials	O-rings: EPDM / FPM	
Characteristics	<ul style="list-style-type: none"> <li>• <b>May be used either vertically and horizontally.</b></li> <li>• 100% factory tested.</li> <li>• Easy installation and maintenance.</li> <li>• Available in PVC-U and Corzan® PVC-C.</li> <li>• Resistance to many inorganic chemicals.</li> <li>• Excellent flow characteristics.</li> </ul>	<ul style="list-style-type: none"> <li>• <b>Se pueden usar indistintamente verticalmente o horizontalmente.</b></li> <li>• Probadas al 100% en fábrica.</li> <li>• Fácil instalación y mantenimiento.</li> <li>• Disponibles en PVC-U y Corzan® PVC-C.</li> <li>• Resistencia a múltiples sustancias químicas inorgánicas.</li> <li>• Excelentes características de conducción.</li> </ul>
Certifications / regulations	Check valve design regulation - ISO 16137:2006	



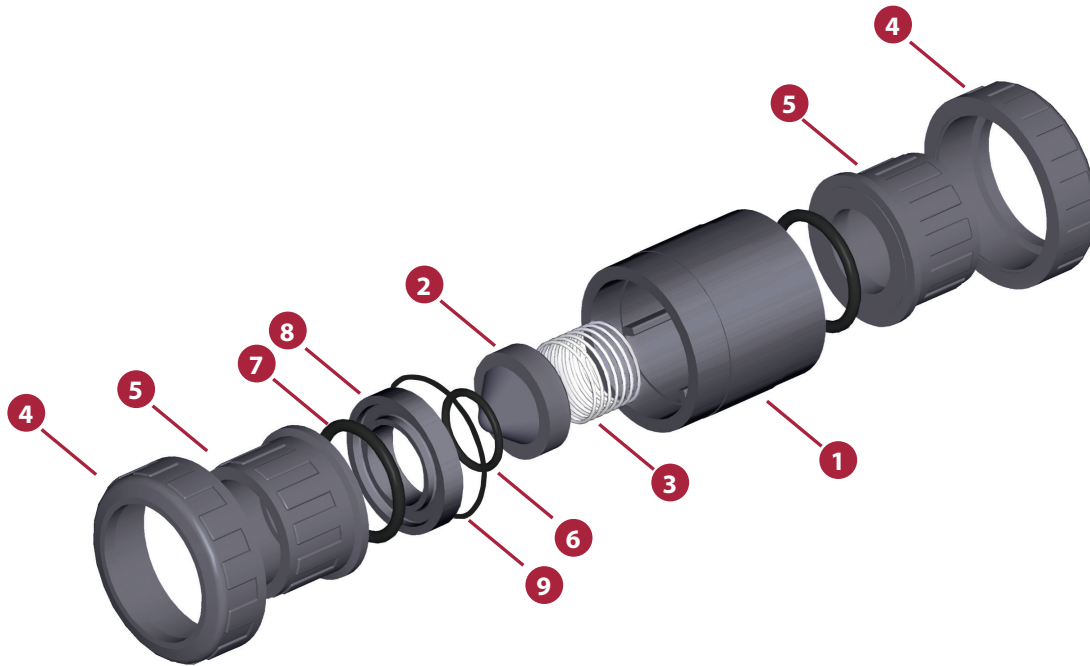
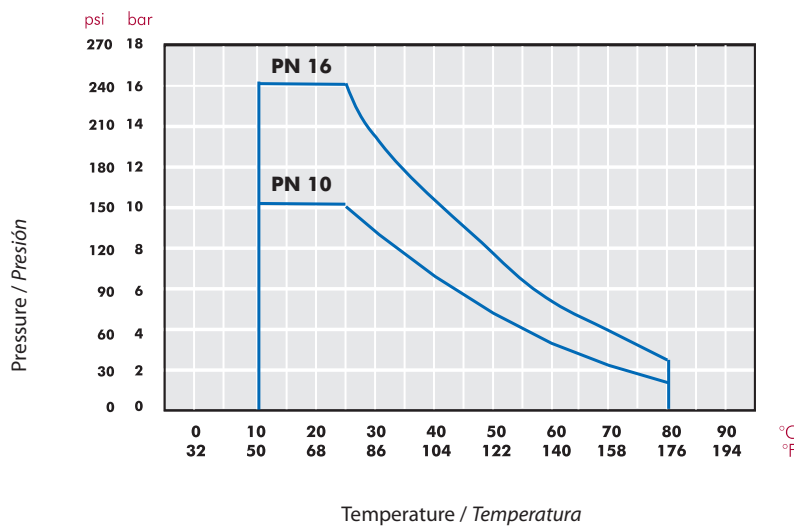

FIG.	Parts	Despiece	Material
1	Body	Cuerpo	PVC-C
2	Cone	Cono de cierre	PVC-C
3	Spring	Muelle	Stainless Steel AISI 302 / PTFE coated *
4	Union nut	Tuerca	PVC-C
5	End connector	Manguito enlace	PVC-C
6	Cone o-ring	Junta cono	EPDM / FPM
7	End connector o-ring	Junta manguito	EPDM / FPM
8	Seal-carrier	Portajuntas	PVC-C
9	Body o-ring	Junta cuerpo	EPDM / FPM

**PRESSURE / TEMPERATURE GRAPH**  
**DIAGRAMA PRESIÓN / TEMPERATURA**



Life: 25 years  
 Hydrostatic maximum pressure a component may withstand in continuous service (without overpressure)

Vida útil: 25 años  
 Presión hidrostática máxima que un componente es capaz de soportar en servicio continuo (sin sobrepresión)

**PRESSURE LOSS DIAGRAM**

**DIAGRAMA DE PÉRDIDAS DE CARGA**

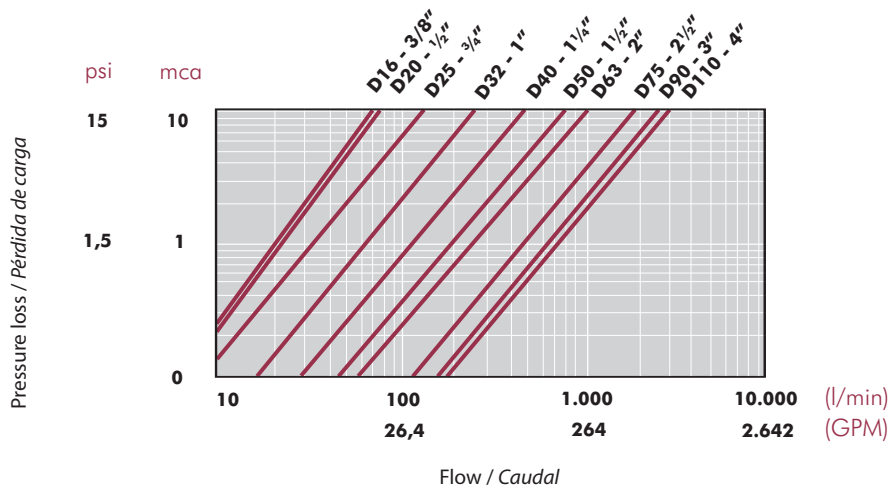

**RELATIVE FLOW**

**FLUJO RELATIVO**

D	20-1/2"	25-3/4"	32-1"	40-1 1/4"	50-1 1/2"	63-2"	75-2 1/2"
DN	15	20	25	32	40	50	65
Kv <sub>100</sub>	68	133	208	383	667	850	1533
Cv	5	9	15	27	47	60	107

$Cv = Kv_{100} / 14,28$   
 $Kv_{100}$  (l/min,  $\Delta p = 1$  bar)  
 $Cv$  (GPM,  $\Delta p = 1$  psi)

**Open**  
**Abierto**

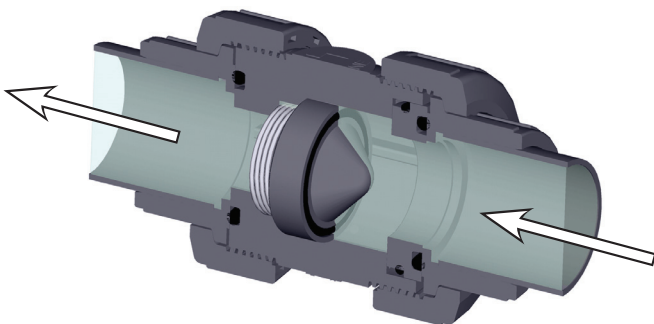

**Closed**  
**Cerrado**

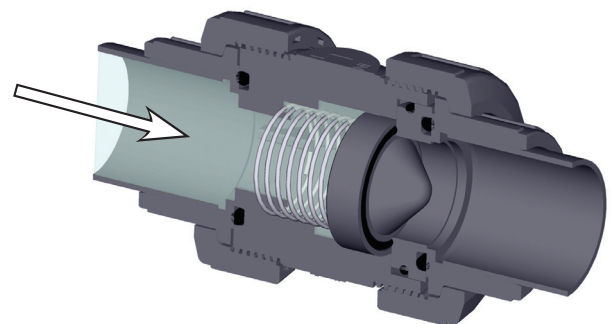

**OPENING PRESSURE**

**PRESIÓN DE APERTURA**

Minimum pressure: opening start  
Maximum pressure: open valve

Minimum pressure: opening start  
Maximum pressure: open valve

D	P (bar) Minimum opening	P (bar) Maximum opening	P (psi) Minimum opening	P (psi) Maximum opening
20	0,11	0,19	1,57	2,71
25	0,035	0,067	0,5	0,95
32	0,042	0,077	0,6	1,1
40	0,038	0,069	0,54	0,98
50	0,063	0,088	0,9	1,25
63	0,038	0,060	0,54	0,85
75	0,031	0,060	0,44	0,85
90	0,025	0,060	0,35	0,85

## ASSEMBLY INSTRUCTIONS

### Solvent socket or threaded unions

Loosen the valve union nuts (4) and separate these and the end connectors (5) from the valve body. Pass the pipe through the nuts and then place the bushes over the end of the pipe. The socket unions should be glued onto the pipe using a PVC-U or PVC-C adhesive and pressure should not be applied to the system until a drying period of at least 1 hour per bar of working pressure has elapsed. In the case of threaded unions, PTFE tape should be applied to the male threads. The pipes can now be attached to the valve by hand tightening down the nuts.

## INSTRUCCIONES DE MONTAJE

### Uniones encoladas o roscadas

Afloje las tuercas (4) de la válvula y sepárelas de los manguitos (5). Introduzca las tuercas en los tubos y a continuación fije los manguitos en los extremos del tubo. Las uniones encoladas se realizarán con un adhesivo para tubos de PVC-U o PVC-C rígido y no se aplicará presión hasta transcurridas al menos 1 hora por bar. En las uniones roscadas se colocará cinta de PTFE en las roscas macho. A continuación ya podrá colocarse la válvula entre los manguitos y apretar a mano las tuercas sobre la válvula.

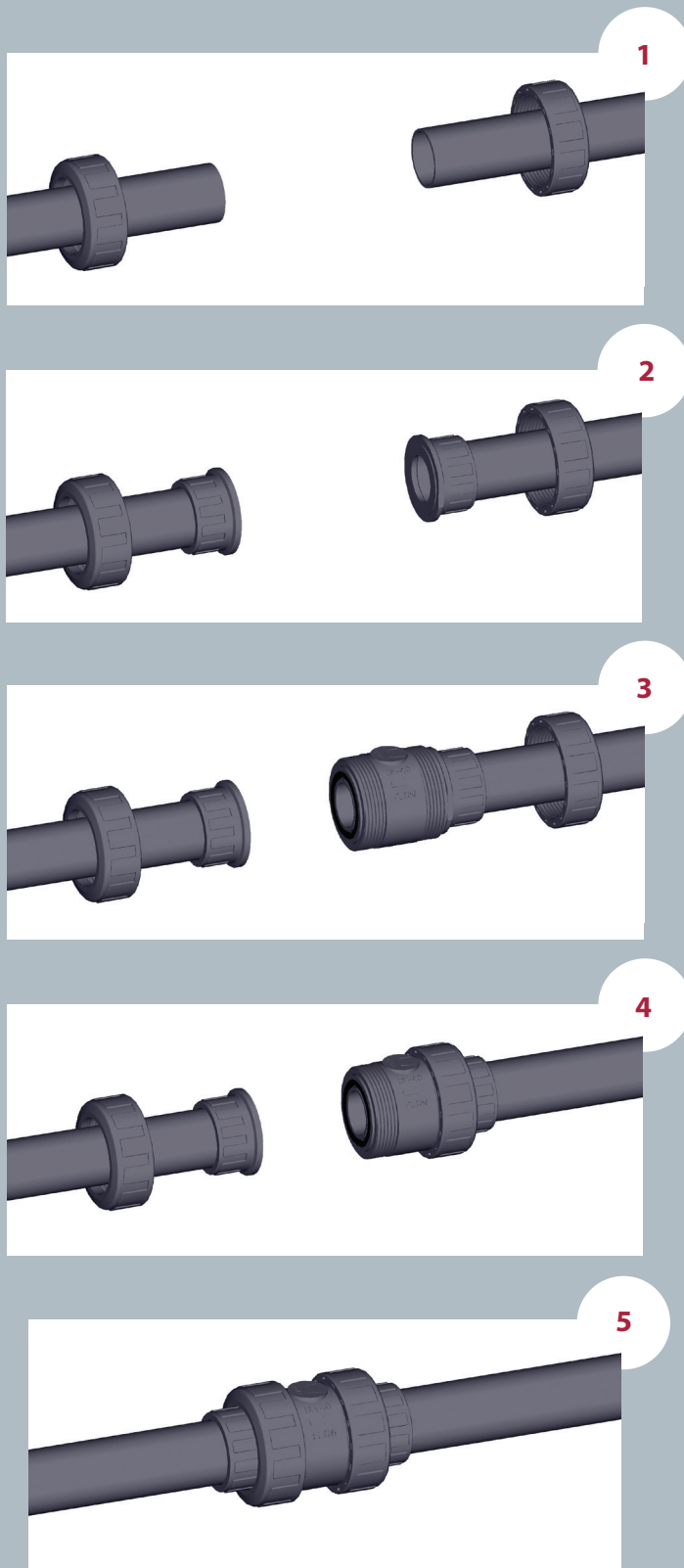

### CP-S. 67. SF1 - PVC-C SPRING CHECK VALVE

**Spring check valve**

- Corzan® PVC-C body
- Female solvent socket
- Metric series
- O-Rings in EPDM

**Válvula anti-retorno**

- Cuerpo en Corzan® PVC-C
- Encolar hembra
- Serie métrica
- Anillos tóricos en EPDM

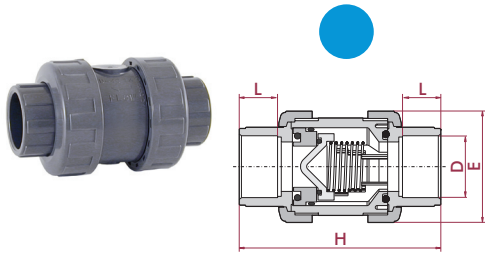

D	DN	PN	REF.	CODE
16	10	16	35 67 016	<b>22844</b>
20	15	16	35 67 020	<b>22845</b>
25	20	16	35 67 025	<b>22846</b>
32	25	16	35 67 032	<b>22847</b>
40	32	16	35 67 040	<b>22848</b>
50	40	16	35 67 050	<b>22849</b>
63	50	16	35 67 063	<b>22850</b>
75	65	10	35 67 075	<b>22851</b>
90	80	10	35 67 090	<b>22852</b>
110	80	10	35 67 110	<b>22853</b>

L	H	E
14	84	52
16	84	52
19	108	62
22	119	70
26	142	84
31	162	94
38	192	117
44	232	148
51	269	179
51	269	179

### CP-S. 67. FT1 - PVC-C SPRING CHECK VALVE

**Spring check valve**

- Corzan® PVC-C body
- BSP female thread
- O-Rings in EPDM

**Válvula anti-retorno**

- Cuerpo en Corzan® PVC-C
- Roscar hembra BSP
- Anillos tóricos en EPDM

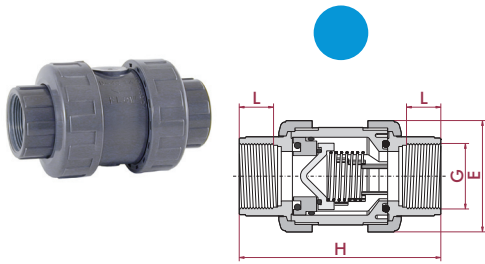

G	DN	PN	REF.	CODE
3/8"	10	16	35 67 616	<b>22854</b>
1/2"	15	16	35 67 620	<b>22855</b>
3/4"	20	16	35 67 625	<b>22856</b>
1"	25	16	35 67 632	<b>22857</b>
1 1/4"	32	16	35 67 640	<b>22858</b>
1 1/2"	40	16	35 67 650	<b>22859</b>
2"	50	16	35 67 663	<b>22860</b>
2 1/2"	65	10	35 67 675	<b>22861</b>
3"	80	10	35 67 690	<b>22862</b>
4"	80	10	35 67 710	<b>22863</b>

L	H	E
14	84	52
16	84	52
19	108	62
22	119	70
26	142	84
31	162	94
38	192	117
44	232	148
51	269	179
51	269	179

### CP-S. 67. SF4 - PVC-C SPRING CHECK VALVE

**Spring check valve**

- Corzan® PVC-C body
- Female solvent socket
- Metric series
- O-Rings in FPM

**Válvula anti-retorno**

- Cuerpo en Corzan® PVC-C
- Encolar hembra
- Serie métrica
- Anillos tóricos en FPM

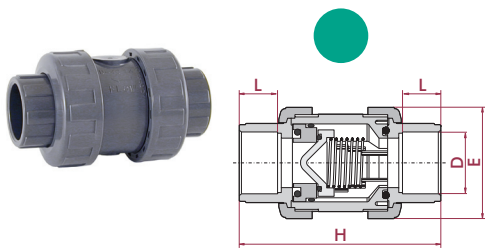

D	DN	PN	REF.	CODE
16	10	16	35 67 016 VI	<b>22864</b>
20	15	16	35 67 020 VI	<b>22865</b>
25	20	16	35 67 025 VI	<b>22866</b>
32	25	16	35 67 032 VI	<b>22867</b>
40	32	16	35 67 040 VI	<b>22868</b>
50	40	16	35 67 050 VI	<b>22869</b>
63	50	16	35 67 063 VI	<b>22870</b>
75	65	10	35 67 075 VI	<b>22871</b>
90	80	10	35 67 090 VI	<b>22872</b>
110	80	10	35 67 110 VI	<b>22873</b>

L	H	E
14	84	52
16	84	52
19	108	62
22	119	70
26	142	84
31	162	94
38	192	117
44	232	148
51	269	179
51	269	179

### CP-S. 67. FT4 - PVC-C SPRING CHECK VALVE

**Spring check valve**

- Corzan® PVC-C body
- BSP female thread
- O-Rings in FPM

**Válvula anti-retorno**

- Cuerpo en Corzan® PVC-C
- Roscar hembra BSP
- Anillos tóricos en FPM

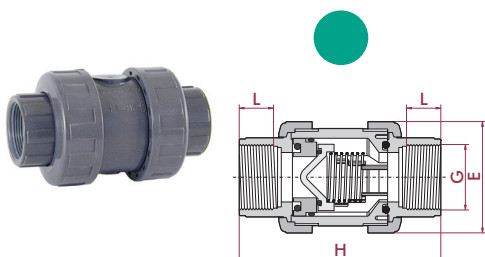

G	DN	PN	REF.	CODE
3/8"	10	16	35 67 616 VI	<b>22874</b>
1/2"	15	16	35 67 620 VI	<b>22875</b>
3/4"	20	16	35 67 625 VI	<b>22876</b>
1"	25	16	35 67 632 VI	<b>22877</b>
1 1/4"	32	16	35 67 640 VI	<b>22878</b>
1 1/2"	40	16	35 67 650 VI	<b>22879</b>
2"	50	16	35 67 663 VI	<b>22880</b>
2 1/2"	65	10	35 67 675 VI	<b>22881</b>
3"	80	10	35 67 690 VI	<b>22882</b>
4"	80	10	35 67 710 VI	<b>22883</b>

L	H	E
14	84	52
16	84	52
19	108	62
22	119	70
26	142	84
31	162	94
38	192	117
44	232	148
51	269	179
51	269	179

## PVC-C CHECK VALVES - BALL SERIES

### VÁLVULAS ANTI-RETORNO PVC-C - SERIE BOLA



Sizes	Solvent cement D20 - D110 (DN15 - DN100) Threaded ½" - 4"	
Standards	Solvent socket - Metric, British standard, ASTM, JIS Threaded - BSP, NPT	EN ISO 1452, EN ISO 15493, BS 4346-1, ASTM D 2467, JIS K 6743 ISO 228-1, ASTM D 2464
Working pressure	@ 20°C (73°F)  D20-D63 (½" - 2"): PN 16 (240 psi) D75 - D110 (2½" - 4"): PN 10 (150 psi)	
Minimum return pressure	<b>0,2 bar (3 psi)</b> <b>Minimal downstream pressure to keep the valve closed in horizontal position.</b> <b>Presión mínima aguas abajo para mantener la válvula cerrada en caso de instalación horizontal.</b>	
Materials	O-rings: EPDM / FPM	
Characteristics	<ul style="list-style-type: none"> <li>• <b>Completely made in plastic - corrosion free.</b></li> <li>• 100% factory tested.</li> <li>• Excellent flow rate.</li> <li>• Easy installation and maintenance.</li> <li>• May be used either vertically and horizontally.</li> <li>• Available in PVC-U and Corzan® PVC-C.</li> <li>• Resistance to many inorganic chemicals.</li> <li>• Excellent flow characteristics.</li> </ul>	<ul style="list-style-type: none"> <li>• <b>Fabricada completamente en plástico - libre de corrosión.</b></li> <li>• Probadas al 100% en fábrica.</li> <li>• Excelente coeficiente de caudal.</li> <li>• Fácil instalación y mantenimiento.</li> <li>• Se pueden usar indistintamente verticalmente o horizontalmente.</li> <li>• Disponibles en PVC-U y Corzan® PVC-C.</li> <li>• Resistencia a múltiples sustancias químicas inorgánicas.</li> <li>• Excelentes características de conducción.</li> </ul>
Certifications / regulations	Check valve design regulation - ISO 16137:2006	

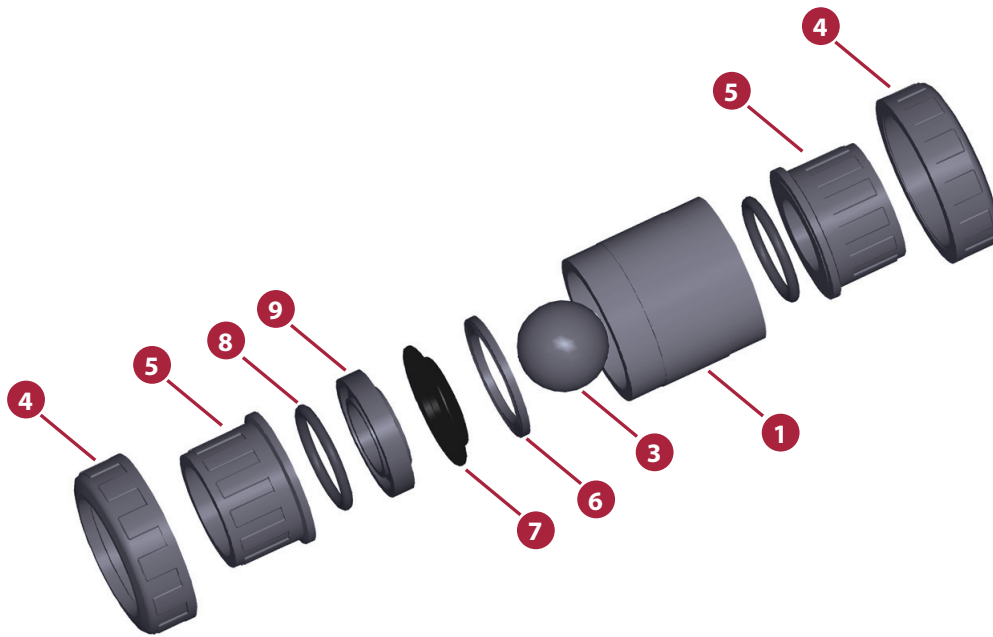
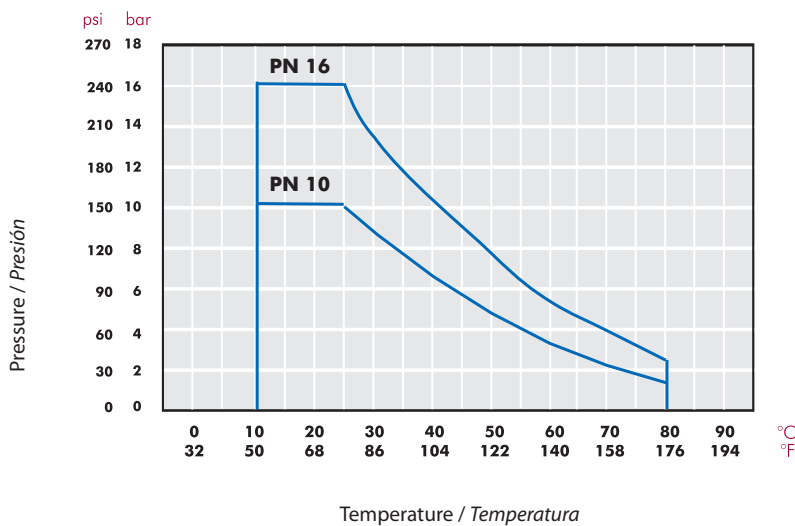

FIG.	Parts	Despiece	Material
1	Body	Cuerpo	PVC-C
3	Ball	Bola	PVC-C
4	Union nut	Tuerca	PVC-C
5	End connector	Manguito enlace	PVC-C
6	Closing ring	Anillo de cierre	PVC-C
7	Body o-ring	Junta cuerpo	EPDM / FPM
8	End connector o-ring	Junta manguito	EPDM / FPM
9	Seal-carrier	Portajuntas	PVC-C

**PRESSURE / TEMPERATURE GRAPH**  
**DIAGRAMA PRESIÓN / TEMPERATURA**



Life: 25 years  
 Hydrostatic maximum pressure a component may withstand in continuous service (without overpressure)

Vida útil: 25 años  
 Presión hidrostática máxima que un componente es capaz de soportar en servicio continuo (sin sobrepresión)

**PRESSURE LOSS DIAGRAM**  
**DIAGRAMA DE PÉRDIDAS DE CARGA**

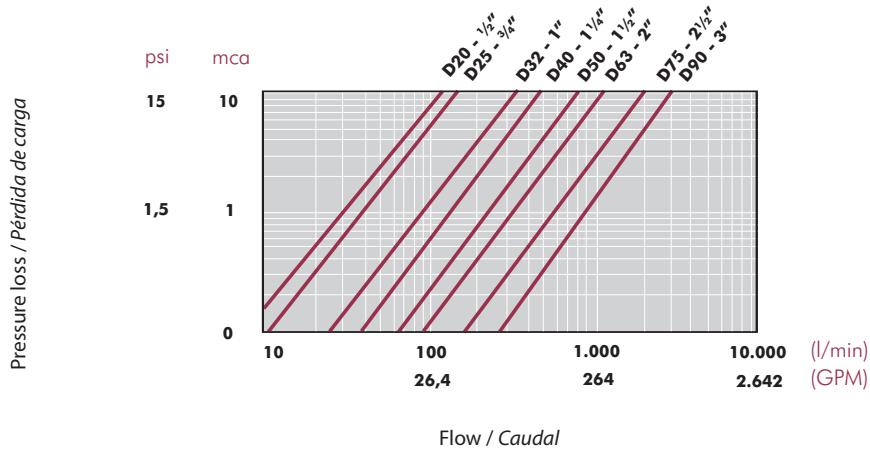

**RELATIVE FLOW**  
**FLUJO RELATIVO**

D	20-1/2"	25-3/4"	32-1"	40-1 1/4"	50-1 1/2"	63-2"	75-2 1/2"	90-3"
DN	15	20	25	32	40	50	65	80
$Kv_{100}$	99	128	308	453	795	1040	1932	2754
Cv	7	9	22	32	56	73	135	193

$Cv = Kv_{100} / 14,28$   
 $Kv_{100}$  (l/min,  $\Delta p = 1$  bar)  
 Cv (GPM,  $\Delta p = 1$  psi)

**Open**  
**Abierto**

**Closed**  
**Cerrado**

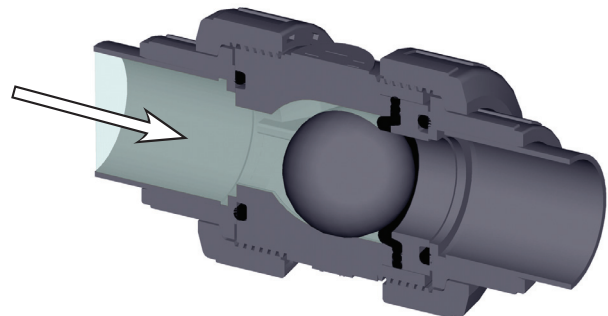
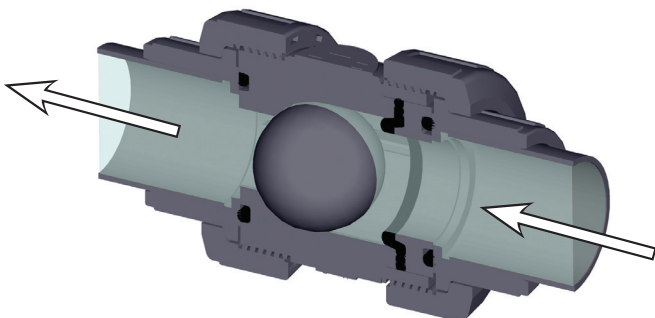

## ASSEMBLY INSTRUCTIONS

### Solvent socket or threaded unions

Loosen the valve union nuts (4) and separate these and the end connectors (5) from the valve body. Pass the pipe through the nuts and then place the bushes over the end of the pipe. The socket unions should be glued onto the pipe using a PVC-U or PVC-C adhesive and pressure should not be applied to the system until a drying period of at least 1 hour per bar of working pressure has elapsed. In the case of threaded unions, PTFE tape should be applied to the male threads. The pipes can now be attached to the valve by hand tightening down the nuts.

## INSTRUCCIONES DE MONTAJE

### Uniones encoladas o roscadas

Afloje las tuercas (4) de la válvula y sepárelas de los manguitos (5). Introduzca las tuercas en los tubos y a continuación fije los manguitos en los extremos del tubo. Las uniones encoladas se realizarán con un adhesivo para tubos de PVC-U o PVC-C rígido y no se aplicará presión hasta transcurridas al menos 1 hora por bar. En las uniones roscadas se colocará cinta de PTFE en las roscas macho. A continuación ya podrá colocarse la válvula entre los manguitos y apretar a mano las tuercas sobre la válvula.

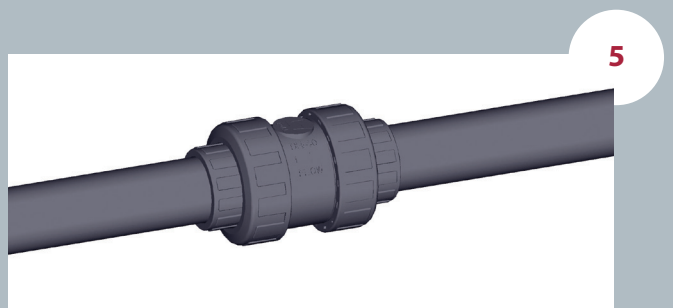
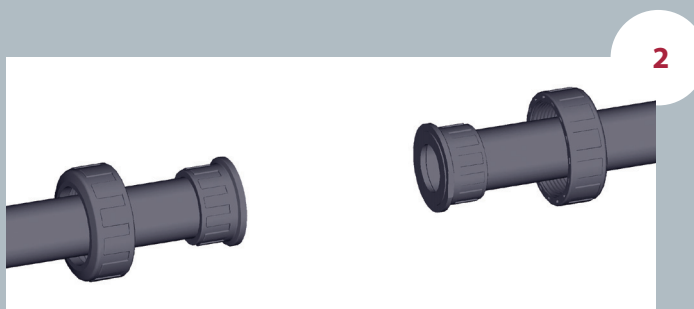
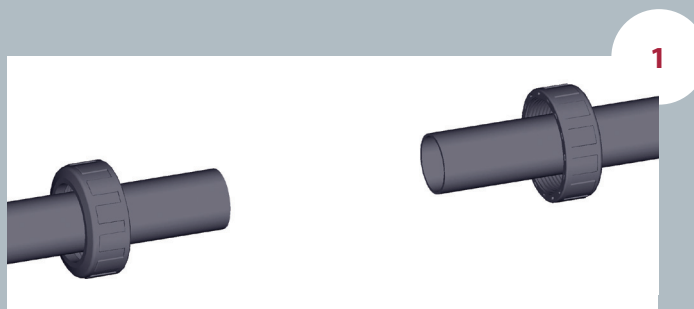



**CP-B. 67. SF1 - PVC-C BALL CHECK VALVE**
**Ball check valve**

- Corzan® PVC-C body
- Female solvent socket
- Metric series
- O-Rings in EPDM

**Válvula anti-retorno de bola**

- Cuerpo en Corzan® PVC-C
- Encolar hembra
- Serie métrica
- Anillos tóricos en EPDM

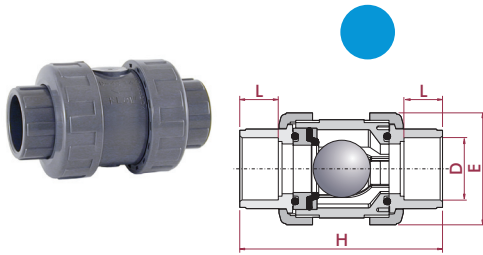

D	DN	PN	REF.	CODE
20	15	16	35 67 220	<b>27501</b>
25	20	16	35 67 225	<b>27502</b>
32	25	16	35 67 232	<b>27503</b>
40	32	16	35 67 240	<b>27504</b>
50	40	16	35 67 250	<b>27505</b>
63	50	16	35 67 263	<b>27506</b>
75	65	10	35 67 275	<b>27507</b>
90	80	10	35 67 290	<b>27508</b>
110	80	10	35 67 310	<b>27509</b>

L	H	E
16	84	52
19	108	62
22	119	70
26	142	84
31	162	94
38	192	117
44	232	148
51	269	179
51	269	179

**CP-B. 67. FT1 - PVC-C BALL CHECK VALVE**
**Ball check valve**

- Corzan® PVC-C body
- BSP female thread
- O-Rings in EPDM

**Válvula anti-retorno de bola**

- Cuerpo en Corzan® PVC-C
- Roscar hembra BSP
- Anillos tóricos en EPDM

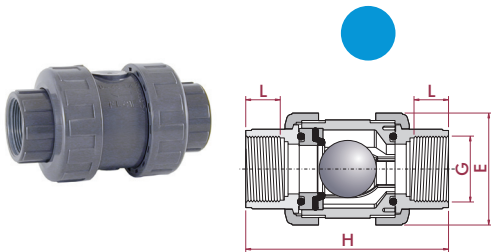

G	DN	PN	REF.	CODE
½"	15	16	35 67 420	<b>27510</b>
¾"	20	16	35 67 425	<b>27511</b>
1"	25	16	35 67 432	<b>27512</b>
1¼"	32	16	35 67 440	<b>27513</b>
1½"	40	16	35 67 450	<b>27514</b>
2"	50	16	35 67 463	<b>27515</b>
2½"	65	10	35 67 475	<b>27516</b>
3"	80	10	35 67 490	<b>27517</b>
4"	80	10	35 67 510	<b>27518</b>

L	H	E
16	84	52
19	108	62
22	119	70
26	142	84
31	162	94
38	192	117
44	232	148
51	269	179
51	269	179

**CP-B. 67. SF4 - PVC-C BALL CHECK VALVE**
**Ball check valve**

- Corzan® PVC-C body
- Female solvent socket
- Metric series
- O-Rings in FPM

**Válvula anti-retorno de bola**

- Cuerpo en Corzan® PVC-C
- Encolar hembra
- Serie métrica
- Anillos tóricos en FPM

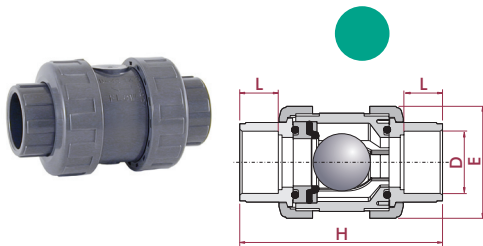

D	DN	PN	REF.	CODE
20	15	16	35 67 220 VI	<b>27519</b>
25	20	16	35 67 225 VI	<b>27520</b>
32	25	16	35 67 232 VI	<b>27521</b>
40	32	16	35 67 240 VI	<b>27522</b>
50	40	16	35 67 250 VI	<b>27523</b>
63	50	16	35 67 263 VI	<b>27524</b>
75	65	10	35 67 275 VI	<b>27525</b>
90	80	10	35 67 290 VI	<b>27526</b>
110	80	10	35 67 310 VI	<b>27527</b>

L	H	E
16	84	52
19	108	62
22	119	70
26	142	84
31	162	94
38	192	117
44	232	148
51	269	179
51	269	179

**CP-B. 67. FT4 - PVC-C BALL CHECK VALVE**
**Ball check valve**

- Corzan® PVC-C body
- BSP female thread
- O-Rings in FPM

**Válvula anti-retorno de bola**

- Cuerpo en Corzan® PVC-C
- Roscar hembra BSP
- Anillos tóricos en FPM

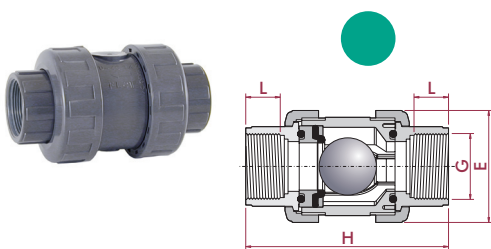

G	DN	PN	REF.	CODE
½"	15	16	35 67 420 VI	<b>27528</b>
¾"	20	16	35 67 425 VI	<b>27529</b>
1"	25	16	35 67 432 VI	<b>27530</b>
1¼"	32	16	35 67 440 VI	<b>27531</b>
1½"	40	16	35 67 450 VI	<b>27532</b>
2"	50	16	35 67 463 VI	<b>27533</b>
2½"	65	10	35 67 475 VI	<b>27534</b>
3"	80	10	35 67 490 VI	<b>27535</b>
4"	80	10	35 67 510 VI	<b>27536</b>

L	H	E
16	84	52
19	108	62
22	119	70
26	142	84
31	162	94
38	192	117
44	232	148
51	269	179
51	269	179

## PVC-C CHECK VALVES - SPRING SERIES

### VÁLVULAS ANTI-RETORNO PVC-C - SERIE MUELLE



Sizes	Solvent cement D16 - D110 (DN10 - DN100) Threaded 3/8" - 4"	
Standards	Solvent socket - Metric, British standard, ASTM, JIS Threaded - BSP, NPT	EN ISO 1452, EN ISO 15493, BS 4346-1, ASTM D 2467, JIS K 6743 ISO 228-1, ASTM D 2464
Working pressure	@ 20°C (73°F)  D16-D63 (3/8" - 2"): PN 16 (240 psi) D75 - D110 (2"1/2 - 4"): PN 10 (150 psi)	
Minimum working pressure		
Materials	O-rings: EPDM / FPM	
Characteristics	<ul style="list-style-type: none"> <li>• <b>May be used either vertically and horizontally.</b></li> <li>• 100% factory tested.</li> <li>• Easy installation and maintenance.</li> <li>• Available in PVC-U and Corzan® PVC-C.</li> <li>• Resistance to many inorganic chemicals.</li> <li>• Excellent flow characteristics.</li> </ul>	<ul style="list-style-type: none"> <li>• <b>Se pueden usar indistintamente verticalmente o horizontalmente.</b></li> <li>• Probadas al 100% en fábrica.</li> <li>• Fácil instalación y mantenimiento.</li> <li>• Disponibles en PVC-U y Corzan® PVC-C.</li> <li>• Resistencia a múltiples sustancias químicas inorgánicas.</li> <li>• Excelentes características de conducción.</li> </ul>
Certifications / regulations	Check valve design regulation - ISO 16137:2006	

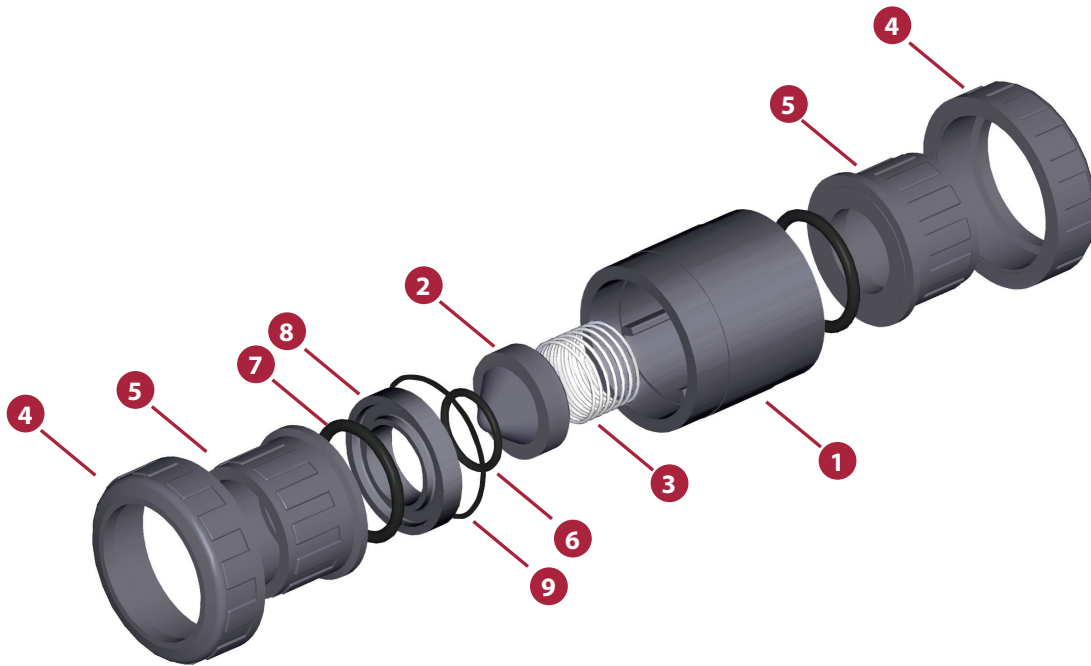
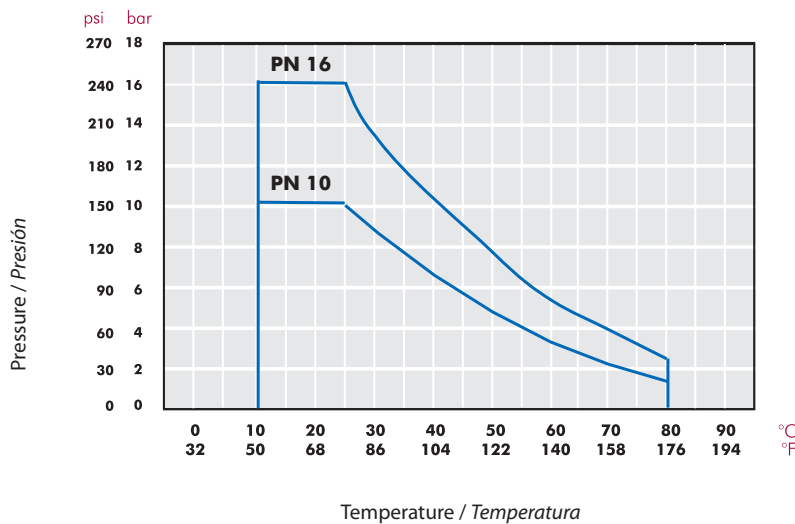

FIG.	Parts	Despiece	Material
1	Body	Cuerpo	PVC-C
2	Cone	Cono de cierre	PVC-C
3	Spring	Muelle	Stainless Steel AISI 302 / PTFE coated *
4	Union nut	Tuerca	PVC-C
5	End connector	Manguito enlace	PVC-C
6	Cone o-ring	Junta cono	EPDM / FPM
7	End connector o-ring	Junta manguito	EPDM / FPM
8	Seal-carrier	Portajuntas	PVC-C
9	Body o-ring	Junta cuerpo	EPDM / FPM

**PRESSURE / TEMPERATURE GRAPH**  
**DIAGRAMA PRESIÓN / TEMPERATURA**



Life: 25 years  
 Hydrostatic maximum pressure a component may withstand in continuous service (without overpressure)

*Vida útil: 25 años*  
*Presión hidrostática máxima que un componente es capaz de soportar en servicio continuo (sin sobrepresión)*

**PRESSURE LOSS DIAGRAM**

**DIAGRAMA DE PÉRDIDAS DE CARGA**

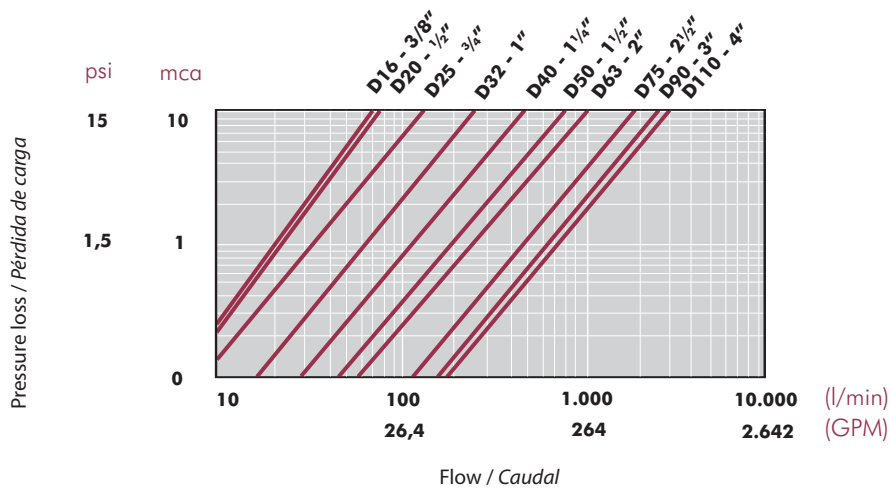

**RELATIVE FLOW**

**FLUJO RELATIVO**

D	20-1/2"	25-3/4"	32-1"	40-1 1/4"	50-1 1/2"	63-2"	75-2 1/2"
DN	15	20	25	32	40	50	65
$Kv_{100}$	68	133	208	383	667	850	1533
Cv	5	9	15	27	47	60	107

$Cv = Kv_{100} / 14,28$   
 $Kv_{100}$  (l/min,  $\Delta p = 1$  bar)  
 $Cv$  (GPM,  $\Delta p = 1$  psi)

**Open**  
**Abierto**

**Closed**  
**Cerrado**

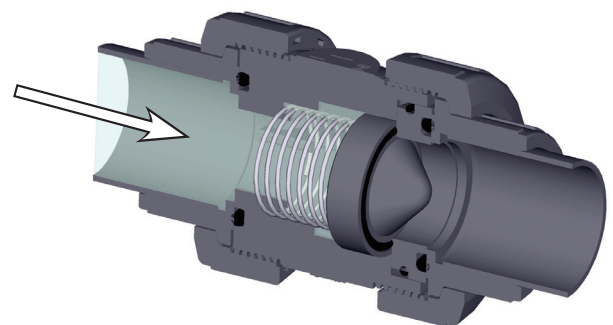
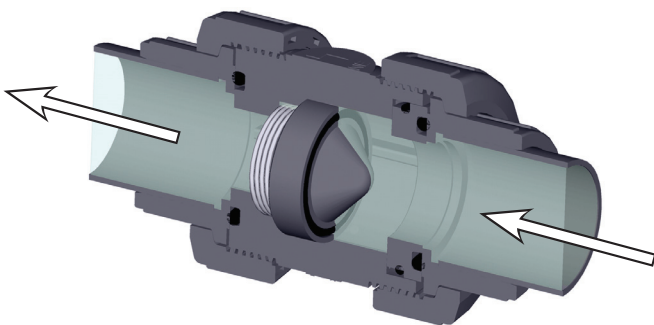

**OPENING PRESSURE**

**PRESIÓN DE APERTURA**

Minimum pressure: opening start  
 Maximum pressure: open valve

*Minimum pressure: opening start*  
*Maximum pressure: open valve*

D	P (bar) Minimum opening	P (bar) Maximum opening	P (psi) Minimum opening	P (psi) Maximum opening
20	0,11	0,19	1,57	2,71
25	0,035	0,067	0,5	0,95
32	0,042	0,077	0,6	1,1
40	0,038	0,069	0,54	0,98
50	0,063	0,088	0,9	1,25
63	0,038	0,060	0,54	0,85
75	0,031	0,060	0,44	0,85
90	0,025	0,060	0,35	0,85

### ASSEMBLY INSTRUCTIONS

#### Solvent socket or threaded unions

Loosen the valve union nuts (4) and separate these and the end connectors (5) from the valve body. Pass the pipe through the nuts and then place the bushes over the end of the pipe. The socket unions should be guided onto the pipe using a PVC-U or PVC-C adhesive and pressure should not be applied to the system until a drying period of at least 1 hour per bar of working pressure has elapsed. In the case of threaded unions, PTFE tape should be applied to the male threads. The pipes can now be attached to the valve by hand tightening down the nuts.

### INSTRUCCIONES DE MONTAJE

#### Uniones encoladas o roscadas

Afloje las tuercas (4) de la válvula y sepárelas de los manguitos (5). Introduzca las tuercas en los tubos y a continuación fije los manguitos en los extremos del tubo. Las uniones encoladas se realizarán con un adhesivo para tubos de PVC-U o PVC-C rígido y no se aplicará presión hasta transcurridas al menos 1 hora por bar. En las uniones roscadas se colocará cinta de PTFE en las roscas macho. A continuación ya podrá colocarse la válvula entre los manguitos y apretar a mano las tuercas sobre la válvula.

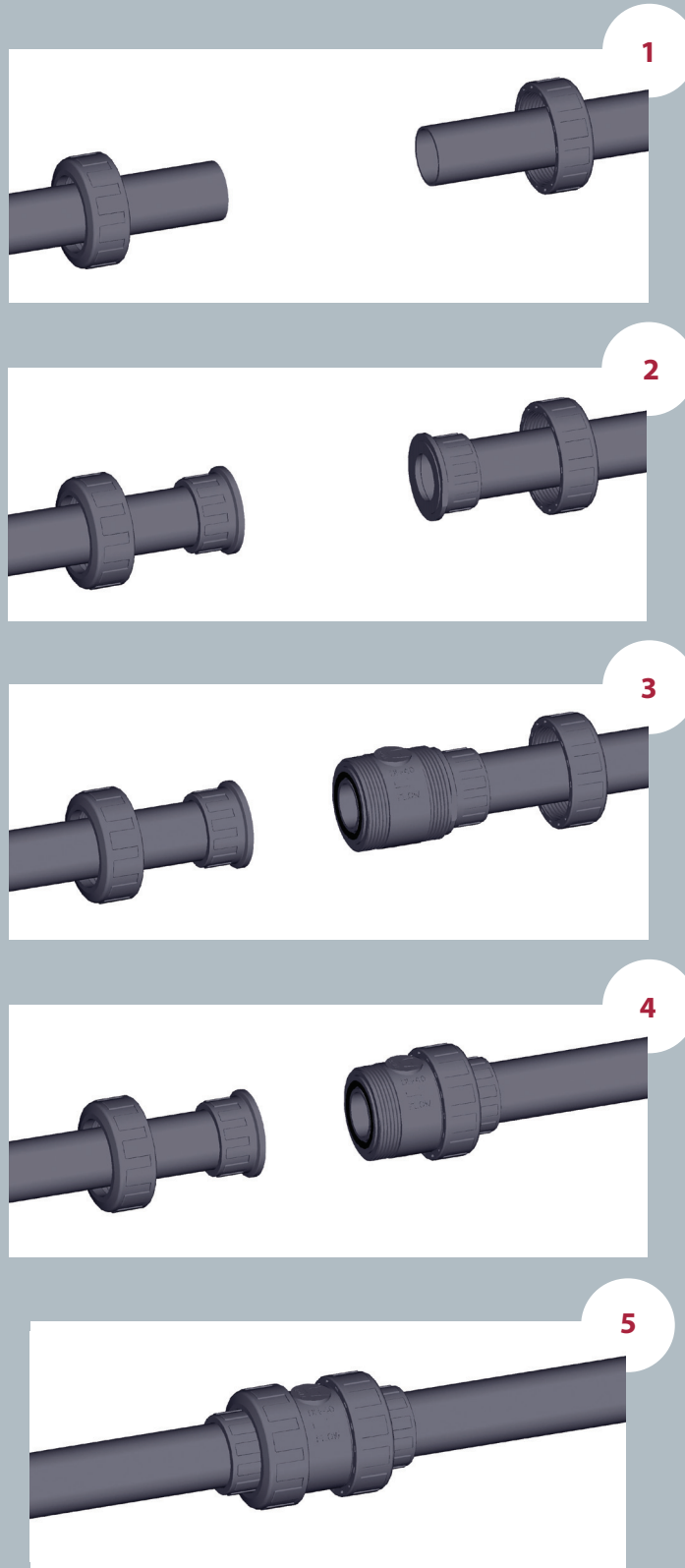

### CP-S. 67. SF1. MA - PVC-C SPRING CHECK VALVE COMBO

**Spring check valve**

- Corzan® PVC-C body
- Female solvent socket
- ASTM series
- O-Rings in EPDM

**Válvula anti-retorno**

- Cuerpo en Corzan® PVC-C
- Encolar hembra
- Serie ASTM
- Anillos tóricos en EPDM

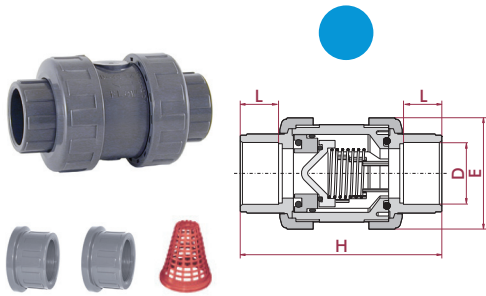

D	DN	PN	REF.	CODE
½"	15	16	35 67 801 D *	<b>22259</b>
¾"	20	16	35 67 802 D *	<b>22260</b>
1"	25	16	35 67 803 D *	<b>22261</b>
1¼"	32	16	35 67 804 D *	<b>22262</b>
1½"	40	16	35 67 805 D *	<b>22263</b>
2"	50	16	35 67 806 D *	<b>22264</b>
2½"	65	10	35 67 907 MAR *	<b>22271</b>
3"	80	10	35 67 908 MAR *	<b>22272</b>
4"	80	10	35 67 910 MAR *	<b>24304</b>

L	H	E
16	84	52
19	108	62
22	119	70
26	142	84
31	162	94
38	192	117
44	232	148
51	269	179
51	269	179

### CP-S. 67. FT1. MA - PVC-C SPRING CHECK VALVE COMBO

**Spring check valve**

- Corzan® PVC-C body
- NPT female thread
- O-Rings in EPDM

**Válvula anti-retorno**

- Cuerpo en Corzan® PVC-C
- Roscar hembra NPT
- Anillos tóricos en EPDM

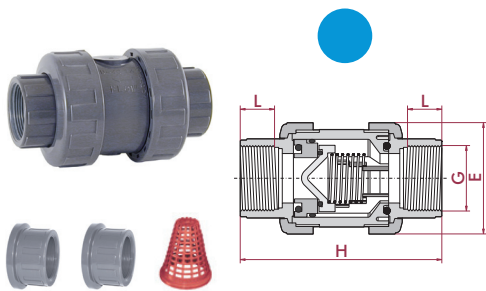

G	DN	PN	REF.	CODE
½"	15	16	35 67 801 D *	<b>22259</b>
¾"	20	16	35 67 802 D *	<b>22260</b>
1"	25	16	35 67 803 D *	<b>22261</b>
1¼"	32	16	35 67 804 D *	<b>22262</b>
1½"	40	16	35 67 805 D *	<b>22263</b>
2"	50	16	35 67 806 D *	<b>22264</b>
2½"	65	10	35 67 807 R *	<b>22273</b>
3"	80	10	35 67 808 R *	<b>22274</b>
4"	80	10	35 67 810 R *	<b>24303</b>

L	H	E
16	84	52
19	108	62
22	119	70
26	142	84
31	162	94
38	192	117
44	232	148
51	269	179
51	269	179

**COMBO VERSION**

- 1½" - 2": valve with solvent socket unions + spare threaded unions in the same box
- 2½" - 4": only solvent sokcet or threaded unions assembled including the grid for transforming the check valve in foot valve

**VERSIÓN COMBO**

- 1½" - 2": manguitos enlace encolar montados + manguitos enlace roscar añadidos en caja
- 2½" - 4": sólo manguitos enlace encolar o roscar e incluyen rejilla para transformación en válvula de pie

**CP-S. 67. SF4. MA - PVC-C SPRING CHECK VALVE COMBO**
**Spring check valve**

- Corzan® PVC-C body
- Female solvent socket
- ASTM series
- O-Rings in FPM

**Válvula anti-retorno**

- Cuerpo en Corzan® PVC-C
- Encolar hembra
- Serie ASTM
- Anillos tóricos en FPM

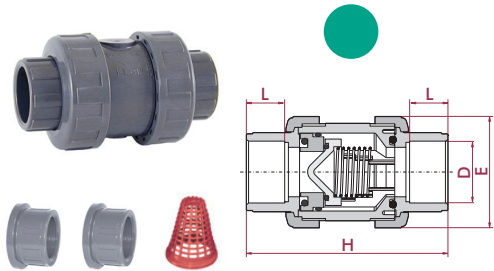

D	DN	PN	REF.	CODE
20	15	16	35 67 801 VID *	<b>22259VIT</b>
25	20	16	35 67 802 VID *	<b>22260VIT</b>
32	25	16	35 67 803 VID *	<b>22261VIT</b>
40	32	16	35 67 804 VID *	<b>22262VIT</b>
50	40	16	35 67 805 VID *	<b>22263VIT</b>
63	50	16	35 67 806 VID *	<b>22264VIT</b>
75	65	10	35 67 907 AVR *	<b>22271VIT</b>
90	80	10	35 67 908 AVR *	<b>22272VIT</b>
110	80	10	35 67 910 AVR *	<b>24304VIT</b>

L	H	E
16	84	52
19	108	62
22	119	70
26	142	84
31	162	94
38	192	117
44	232	148
51	269	179
51	269	179

**CP-S. 67. FT4. MA - PVC-C SPRING CHECK VALVE COMBO**
**Spring check valve**

- Corzan® PVC-C body
- NPT female thread
- O-Rings in FPM

**Válvula anti-retorno**

- Cuerpo en Corzan® PVC-C
- Roscar hembra NPT
- Anillos tóricos en FPM

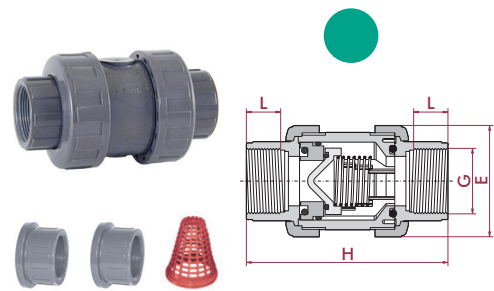

G	DN	PN	REF.	CODE
½"	15	16	35 67 801 VID *	<b>22259VIT</b>
¾"	20	16	35 67 802 VID *	<b>22260VIT</b>
1"	25	16	35 67 803 VID *	<b>22261VIT</b>
1¼"	32	16	35 67 804 VID *	<b>22262VIT</b>
1½"	40	16	35 67 805 VID *	<b>22263VIT</b>
2"	50	16	35 67 806 VID *	<b>22264VIT</b>
2½"	65	10	35 67 807 VIR *	<b>22273VIT</b>
3"	80	10	35 67 808 VIR *	<b>22274VIT</b>
4"	80	10	35 67 810 VIR *	<b>24303VIT</b>

L	H	E
16	84	52
19	108	62
22	119	70
26	142	84
31	162	94
38	192	117
44	232	148
51	269	179
51	269	179

**COMBO VERSION**

- 1½" - 2": valve with solvent socket unions + spare threaded unions in the same box
- 2½" - 4": only solvent socket or threaded unions assembled including the grid for transforming the check valve in foot valve

**VERSIÓN COMBO**

- 1½" - 2": manguitos enlace encolar montados + manguitos enlace roscar añadidos en caja
- 2½" - 4": sólo manguitos enlace encolar o roscar e incluyen rejilla para transformación en válvula de pie

## PVC-C CHECK VALVES - BALL SERIES

### VÁLVULAS ANTI-RETORNO PVC-C - SERIE BOLA



Sizes	Solvent cement D20 - D110 (DN15 - DN100) Threaded ½" - 4"	
Standards	Solvent socket - Metric, British standard, ASTM, JIS Threaded - BSP, NPT	EN ISO 1452, EN ISO 15493, BS 4346-1, ASTM D 2467, JIS K 6743 ISO 228-1, ASTM D 2464
Working pressure	@ 20°C (73°F)  D20-D63 (½" - 2"): PN 16 (240 psi) D75 - D110 (2½" - 4"): PN 10 (150 psi)	
Minimum return pressure	<b>0,2 bar (3 psi)</b> <b>Minimal downstream pressure to keep the valve closed in horizontal position.</b> <b>Presión mínima aguas abajo para mantener la válvula cerrada en caso de instalación horizontal.</b>	
Materials	O-rings: EPDM / FPM	
Characteristics	<ul style="list-style-type: none"> <li>• <b>Completely made in plastic - corrosion free.</b></li> <li>• 100% factory tested.</li> <li>• Excellent flow rate.</li> <li>• Easy installation and maintenance.</li> <li>• May be used either vertically and horizontally.</li> <li>• Available in PVC-U and Corzan® PVC-C.</li> <li>• Resistance to many inorganic chemicals.</li> <li>• Excellent flow characteristics.</li> </ul>	<ul style="list-style-type: none"> <li>• <b>Fabricada completamente en plástico - libre de corrosión.</b></li> <li>• Probadas al 100% en fábrica.</li> <li>• Excelente coeficiente de caudal.</li> <li>• Fácil instalación y mantenimiento.</li> <li>• Se pueden usar indistintamente verticalmente o horizontalmente.</li> <li>• Disponibles en PVC-U y Corzan® PVC-C.</li> <li>• Resistencia a múltiples sustancias químicas inorgánicas.</li> <li>• Excelentes características de conducción.</li> </ul>
Certifications / regulations	Check valve design regulation - ISO 16137:2006	



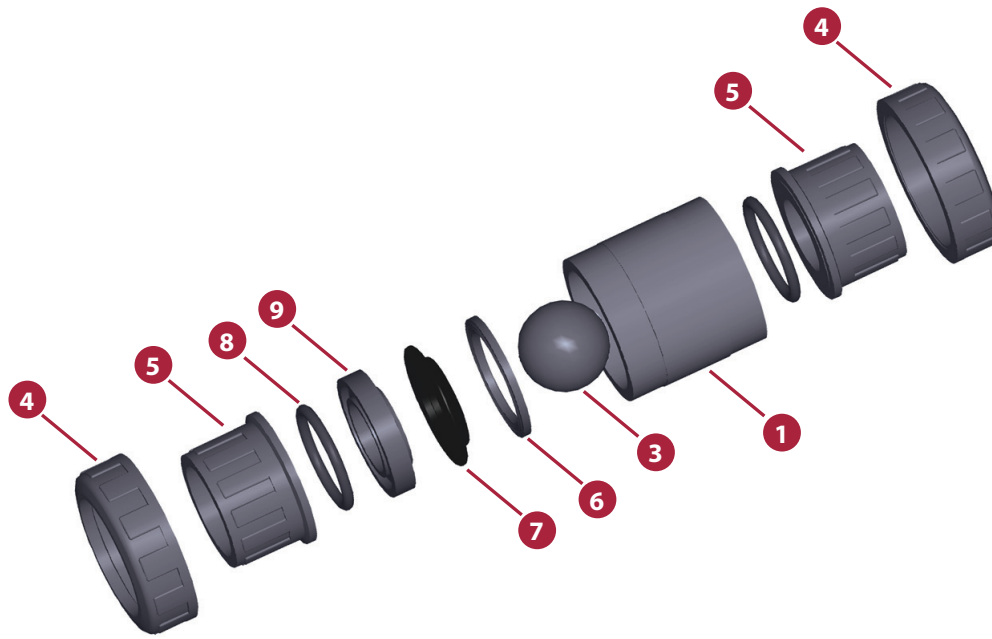
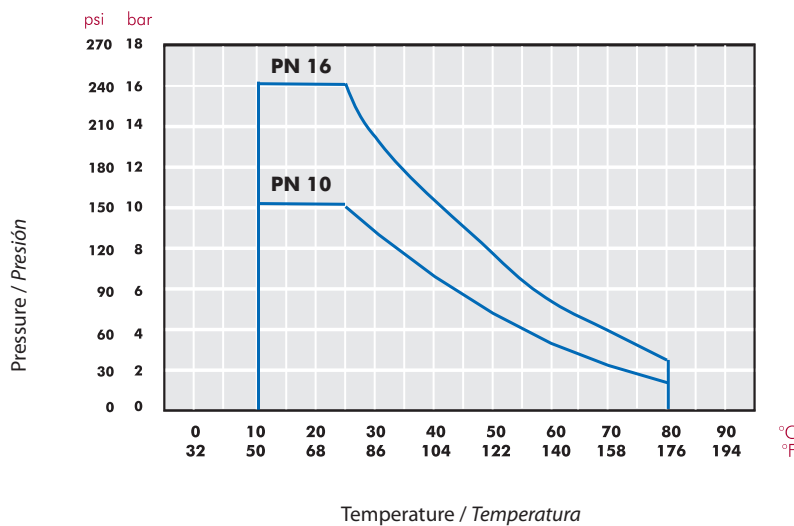

FIG.	Parts	Despiece	Material
1	Body	Cuerpo	PVC-C
3	Ball	Bola	PVC-C
4	Union nut	Tuerca	PVC-C
5	End connector	Manguito enlace	PVC-C
6	Closing ring	Anillo de cierre	PVC-C
7	Body o-ring	Junta cuerpo	EPDM / FPM
8	End connector o-ring	Junta manguito	EPDM / FPM
9	Seal-carrier	Portajuntas	PVC-C

**PRESSURE / TEMPERATURE GRAPH**  
**DIAGRAMA PRESIÓN / TEMPERATURA**



Life: 25 years  
Hydrostatic maximum pressure a component may withstand in continuous service (without overpressure)

Vida útil: 25 años  
Presión hidrostática máxima que un componente es capaz de soportar en servicio continuo (sin sobrepresión)

**PRESSURE LOSS DIAGRAM**  
**DIAGRAMA DE PÉRDIDAS DE CARGA**

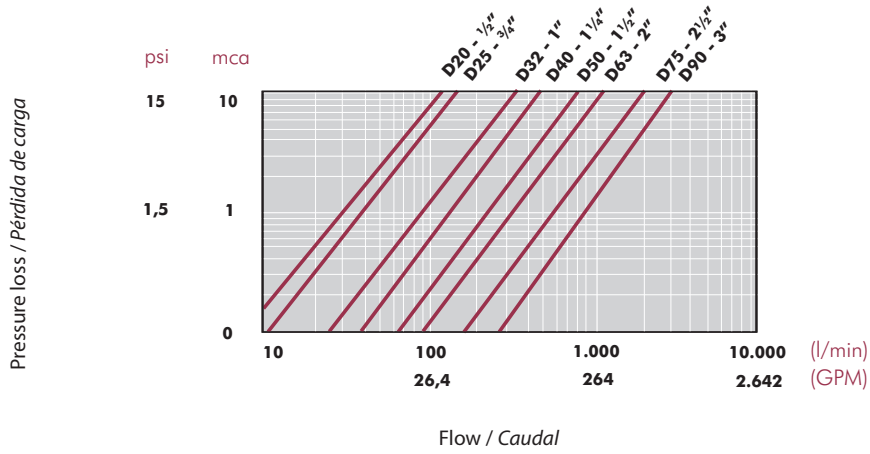

**RELATIVE FLOW**  
**FLUJO RELATIVO**

D	20-1/2"	25-3/4"	32-1"	40-1 1/4"	50-1 1/2"	63-2"	75-2 1/2"	90-3"
DN	15	20	25	32	40	50	65	80
$K_{v100}$	99	128	308	453	795	1040	1932	2754
Cv	7	9	22	32	56	73	135	193

$Cv = K_{v100} / 14,28$   
 $K_{v100}$  (l/min,  $\Delta p = 1$  bar)  
 Cv (GPM,  $\Delta p = 1$  psi)

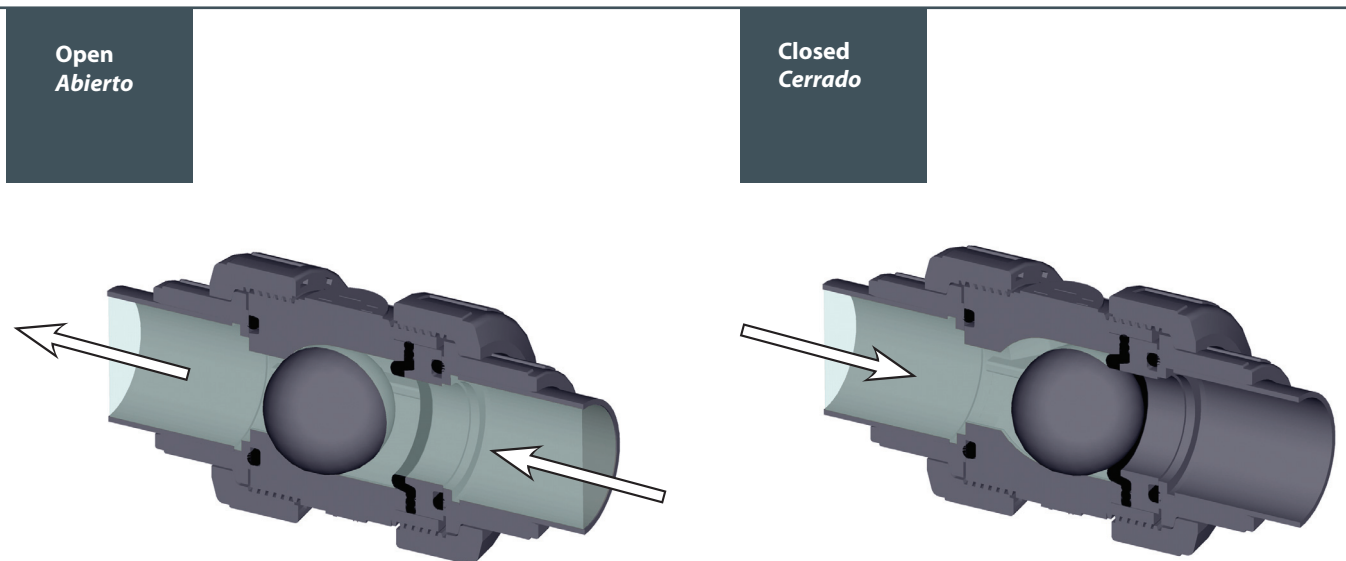

### ASSEMBLY INSTRUCTIONS

#### Solvent socket or threaded unions

Loosen the valve union nuts (4) and separate these and the end connectors (5) from the valve body. Pass the pipe through the nuts and then place the bushes over the end of the pipe. The socket unions should be glued onto the pipe using a PVC-U or PVC-C adhesive and pressure should not be applied to the system until a drying period of at least 1 hour per bar of working pressure has elapsed. In the case of threaded unions, PTFE tape should be applied to the male threads. The pipes can now be attached to the valve by hand tightening down the nuts.

### INSTRUCCIONES DE MONTAJE

#### Uniones encoladas o roscadas

Afloje las tuercas (4) de la válvula y sepárelas de los manguitos (5). Introduzca las tuercas en los tubos y a continuación fije los manguitos en los extremos del tubo. Las uniones encoladas se realizarán con un adhesivo para tubos de PVC-U o PVC-C rígido y no se aplicará presión hasta transcurridas al menos 1 hora por bar. En las uniones roscadas se colocará cinta de PTFE en las roscas macho. A continuación ya podrá colocarse la válvula entre los manguitos y apretar a mano las tuercas sobre la válvula.

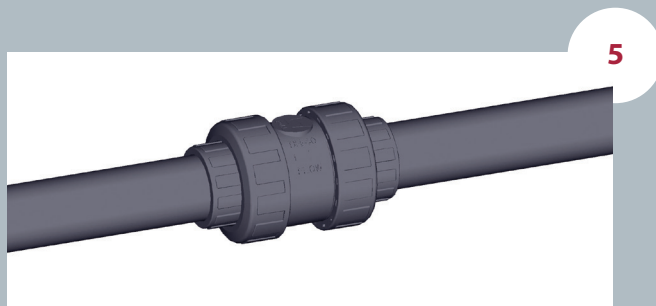
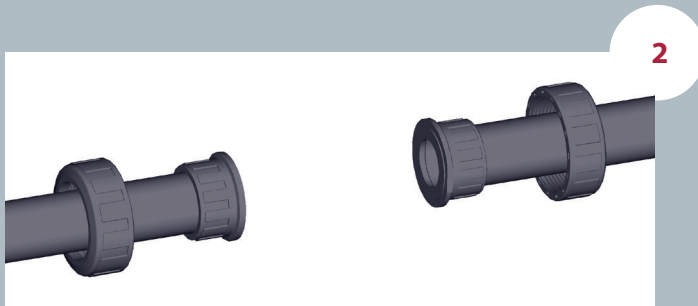
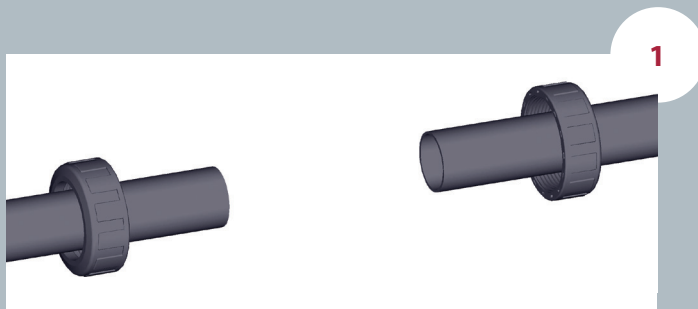

### CP-B. 67. SF1. MA - PVC-C BALL CHECK VALVE

**Ball check valve**

- Corzan® PVC-C body
- Female solvent socket
- ASTM series
- O-Rings in EPDM

**Válvula anti-retorno de bola**

- Cuerpo en Corzan® PVC-C
- Encolar hembra
- Serie ASTM
- Anillos tóricos en EPDM

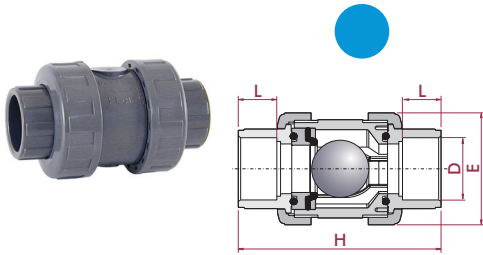

D	DN	PN	REF.	CODE
½"	15	16		
¾"	20	16	35 67 902 EMA	<b>69180</b>
1"	25	16	35 67 903 EMA	<b>61272</b>
1¼"	32	16	35 67 904 EMA	<b>61273</b>
1½"	40	16	35 67 905 EMA	<b>72451</b>
2"	50	16	35 67 906 EMA	<b>67374</b>
2½"	65	10		
3"	80	10	35 67 908 EMA	<b>72589</b>
4"	80	10		

L	H	E
16	84	52
19	108	62
22	119	70
26	142	84
31	162	94
38	192	117
44	232	148
51	269	179
51	269	179

### CP-B. 67. SF1. MA - PVC-C BALL CHECK VALVE COMBO

**Ball check valve**

- Corzan® PVC-C body
- Female solvent socket
- ASTM series
- O-Rings in EPDM

**Válvula anti-retorno de bola**

- Cuerpo en Corzan® PVC-C
- Encolar hembra
- Serie ASTM
- Anillos tóricos en EPDM

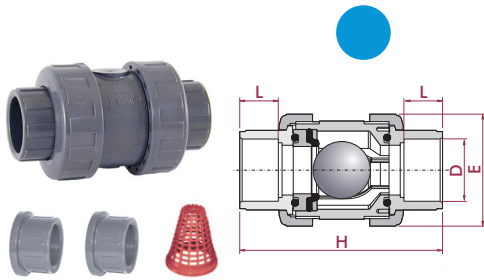

D	DN	PN	REF.	CODE
½"	15	16	35 67 801 ED *	<b>27380</b>
¾"	20	16	35 67 802 ED *	<b>27381</b>
1"	25	16	35 67 803 ED *	<b>27382</b>
1¼"	32	16	35 67 804 ED *	<b>27383</b>
1½"	40	16	35 67 805 ED *	<b>27384</b>
2"	50	16	35 67 806 ED *	<b>27385</b>
2½"	65	10	35 67 907 EMAR *	<b>27397</b>
3"	80	10	35 67 908 EMAR *	<b>27398</b>
4"	80	10	35 67 910 EMAR *	<b>27433</b>

L	H	E
16	84	52
19	108	62
22	119	70
26	142	84
31	162	94
38	192	117
44	232	148
51	269	179
51	269	179

### CP-B. 67. FT1. MA - PVC-C BALL CHECK VALVE COMBO

**Ball check valve**

- Corzan® PVC-C body
- NPT female thread
- O-Rings in EPDM

**Válvula anti-retorno de bola**

- Cuerpo en Corzan® PVC-C
- Roscar hembra NPT
- Anillos tóricos en EPDM

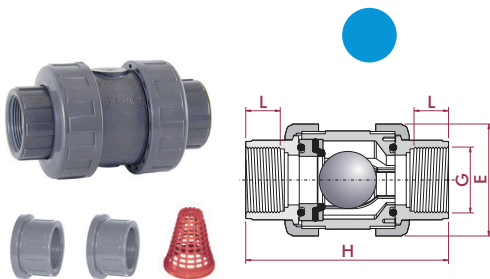

G	DN	PN	REF.	CODE
½"	15	16	35 67 801 ED *	<b>27380</b>
¾"	20	16	35 67 802 ED *	<b>27381</b>
1"	25	16	35 67 803 ED *	<b>27382</b>
1¼"	32	16	35 67 804 ED *	<b>27383</b>
1½"	40	16	35 67 805 ED *	<b>27384</b>
2"	50	16	35 67 806 ED *	<b>27385</b>
2½"	65	10	35 67 807 ER *	<b>27392</b>
3"	80	10	35 67 808 ER *	<b>27393</b>
4"	80	10	35 67 810 ER *	<b>27432</b>

L	H	E
16	84	52
19	108	62
22	119	70
26	142	84
31	162	94
38	192	117
44	232	148
51	269	179
51	269	179

**COMBO VERSION**

- 1½" - 2": valve with solvent socket unions + spare threaded unions in the same box
- 2½" - 4": only solvent socket or threaded unions assembled including the grid for transforming the check valve in foot valve

**VERSIÓN COMBO**

- 1½" - 2": manguitos enlace encolar montados + manguitos enlace roscar añadidos en caja
- 2½" - 4": sólo manguitos enlace encolar o roscar e incluyen rejilla para transformación en válvula de pie

**CP-B. 67. SF4. MA - PVC-C BALL CHECK VALVE**
**Ball check valve**

- Corzan® PVC-C body
- Female solvent socket
- ASTM series
- O-Rings in FPM

**Válvula anti-retorno de bola**

- Cuerpo en Corzan® PVC-C
- Encolar hembra
- Serie ASTM
- Anillos tóricos en FPM



D	DN	PN	REF.	CODE
½"	15	16	35 67 901 EAV	<b>69135</b>
¾"	20	16	35 67 902 EAV	<b>69136</b>
1"	25	16	35 67 903 EAV	<b>69137</b>
1¼"	32	16	35 67 904 EAV	<b>69138</b>
1½"	40	16	35 67 905 EAV	<b>69139</b>
2"	50	16	35 67 906 EAV	<b>69140</b>
2½"	65	10	35 67 907 EAV	<b>71978</b>
3"	80	10	35 67 908 EAV	<b>71979</b>
4"	80	10	35 67 910 EAV	<b>71980</b>

L	H	E
16	84	52
19	108	62
22	119	70
26	142	84
31	162	94
38	192	117
44	232	148
51	269	179
51	269	179

**CP-B. 67. SF4. MA - PVC-C BALL CHECK VALVE COMBO**
**Ball check valve**

- Corzan® PVC-C body
- Female solvent socket
- ASTM series
- O-Rings in FPM

**Válvula anti-retorno de bola**

- Cuerpo en Corzan® PVC-C
- Encolar hembra
- Serie ASTM
- Anillos tóricos en FPM

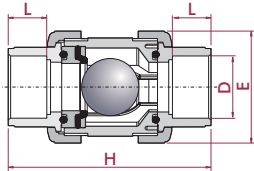

D	DN	PN	REF.	CODE
½"	15	16	35 67 801 VED *	<b>27386</b>
¾"	20	16	35 67 802 VED *	<b>27387</b>
1"	25	16	35 67 803 VED *	<b>27388</b>
1¼"	32	16	35 67 804 VED *	<b>27389</b>
1½"	40	16	35 67 805 VED *	<b>27390</b>
2"	50	16	35 67 806 VED *	<b>27391</b>
2½"	65	10	35 67 907 VEMAR *	<b>27399</b>
3"	80	10	35 67 908 VEMAR *	<b>27400</b>
4"	80	10	35 67 910 VEMAR *	<b>27401</b>

L	H	E
16	84	52
19	108	62
22	119	70
26	142	84
31	162	94
38	192	117
44	232	148
51	269	179
51	269	179

**CP-B. 67. FT4. MA - PVC-C BALL CHECK VALVE COMBO**
**Ball check valve**

- Corzan® PVC-C body
- NPT female thread
- O-Rings in FPM

**Válvula anti-retorno de bola**

- Cuerpo en Corzan® PVC-C
- Roscar hembra NPT
- Anillos tóricos en FPM

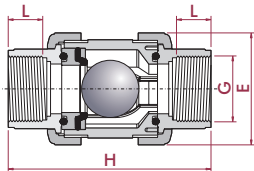

G	DN	PN	REF.	CODE
½"	15	16	35 67 801 VED *	<b>27386</b>
¾"	20	16	35 67 802 VED *	<b>27387</b>
1"	25	16	35 67 803 VED *	<b>27388</b>
1¼"	32	16	35 67 804 VED *	<b>27389</b>
1½"	40	16	35 67 805 VED *	<b>27390</b>
2"	50	16	35 67 806 VED *	<b>27391</b>
2½"	65	10	35 67 807 VER *	<b>27394</b>
3"	80	10	35 67 808 VER *	<b>27395</b>
4"	80	10	35 67 810 VER *	<b>27396</b>

L	H	E
16	84	52
19	108	62
22	119	70
26	142	84
31	162	94
38	192	117
44	232	148
51	269	179
51	269	179

**COMBO VERSION**

- 1½" - 2": valve with solvent socket unions + spare threaded unions in the same box
- 2½" - 4": only solvent socket or threaded unions assembled including the grid for transforming the check valve in foot valve

**VERSIÓN COMBO**

- 1½" - 2": manguitos enlace encolar montados + manguitos enlace roscar añadidos en caja
- 2½" - 4": sólo manguitos enlace encolar o roscar e incluyen rejilla para transformación en válvula de pie