



# Standard Specification for Seamless and Welded Carbon Steel Water-Well Pipe<sup>1</sup>

This standard is issued under the fixed designation A589/A589M; the number immediately following the designation indicates the year of original adoption or, in the case of revision, the year of last revision. A number in parentheses indicates the year of last reapproval. A superscript epsilon ( $\epsilon$ ) indicates an editorial change since the last revision or reapproval.

*This standard has been approved for use by agencies of the U.S. Department of Defense.*

## 1. Scope\*

1.1 This specification covers four specific types of plain end or threaded and coupled carbon steel pipe for use in water wells.

1.2 Each type of water well pipe shall conform to the following methods of manufacture and grade as specified on the purchase order:

1.2.1 *Type I, Drive Pipe*—Seamless or electric-resistance-welded, Grades A and B.

1.2.2 *Type II, Water-Well Reamed and Drifted Pipe*—Seamless or electric-resistance-welded, Grades A and B, or furnace-butt welded.

1.2.3 *Type III, Driven Well Pipe*—Seamless or electric-resistance-welded, Grades A and B, or furnace-butt welded.

1.2.4 *Type IV, Water-Well Casing Pipe*—Seamless or electric-resistance-welded, Grades A and B, or furnace-butt welded.

1.3 The values stated in either inch-pound units or in SI units are to be regarded separately as standard. Within the text, the SI units are shown in brackets. The values in each system are not exact equivalents; therefore, each system is to be used independently of the other. Combining values from the two systems may result in nonconformance with the standard.

NOTE 1—The dimensionless designator NPS (nominal pipe size) and DN (Nominal Diameter) have been substituted in this standard for such traditional terms as “nominal diameter,” “size,” and “nominal size.”

## 2. Referenced Documents

2.1 *ASTM Standards:*<sup>2</sup>

[A53/A53M Specification for Pipe, Steel, Black and Hot-Dipped, Zinc-Coated, Welded and Seamless](#)

[A370 Test Methods and Definitions for Mechanical Testing of Steel Products](#)

<sup>1</sup> This specification is under the jurisdiction of ASTM Committee A01 on Steel, Stainless Steel and Related Alloys and is the direct responsibility of Subcommittee A01.09 on Carbon Steel Tubular Products.

Current edition approved March 1, 2012. Published November 2012. Originally approved in 1968. Last previous edition approved in 2006 as A589 – 06. DOI: 10.1520/A0589\_A0589M-06R12.

<sup>2</sup> For referenced ASTM standards, visit the ASTM website, [www.astm.org](http://www.astm.org), or contact ASTM Customer Service at [service@astm.org](mailto:service@astm.org). For *Annual Book of ASTM Standards* volume information, refer to the standard's Document Summary page on the ASTM website.

[A751 Test Methods, Practices, and Terminology for Chemical Analysis of Steel Products](#)

[A865 Specification for Threaded Couplings, Steel, Black or Zinc-Coated \(Galvanized\) Welded or Seamless, for Use in Steel Pipe Joints](#)

2.2 *API Standard:*

[5L Specification for Line Pipe](#)<sup>3</sup>

## 3. Terminology

3.1 *Definitions of Terms Specific to This Standard:*

3.1.1 *defect*—an imperfection of sufficient size or magnitude to be cause for rejection.

3.1.2 *imperfection*—any discontinuity or irregularity found in the pipe.

## 4. Ordering Information

4.1 Orders for material to this specification should include the following, as required to describe the desired material adequately:

4.1.1 Quantity (feet or number of lengths),

4.1.2 Name of material or type number (see 1.2),

4.1.3 Method of manufacture (furnace-butt welded, seamless, or electric-resistance-welded),

4.1.4 Grade (A or B for seamless or electric-resistance welded),

4.1.5 Finish (black or galvanized),

4.1.6 Dimensions (NPS or outside diameter and wall thickness, or both, for Types I, II, and III. Outside diameter and wall thickness for Type IV),

4.1.7 End finish (plain end or threaded and coupled),

4.1.8 Coupling class for Type III (standard pipe, line pipe, or reamed and drifted pipe coupling),

4.1.9 Coupling make-up (hand tight or power tight),

4.1.10 Length (required random range length or special lengths),

4.1.11 Specification designation, and

4.1.12 Special requirements.

<sup>3</sup> Available from American Petroleum Institute (API), 1220 L. St., NW, Washington, DC 20005.

\*A Summary of Changes section appears at the end of this standard

## 5. Materials and Manufacture

5.1 The steel for both seamless and welded pipe shall be made by one of the following processes: open-hearth, electric-furnace, or basic-oxygen.

5.2 Steel may be cast in ingots or may be strand cast. When steels of different grades are sequentially strand cast, identification of the resultant transition material is required. The producer shall remove the transition material by any established procedure that positively separates the grades.

## 6. Chemical Composition

6.1 The steel shall conform to the following requirements as to chemical composition:

Phosphorus, max, %	0.050
Sulfur, max, %	0.060

## 7. Heat Analysis

7.1 An analysis of each heat of steel shall be made by the manufacturer to determine the percentage of the elements specified in 6.1. When requested by the purchaser, the chemical composition thus determined shall be reported to the purchaser, and shall conform to the requirements specified in 6.1.

## 8. Product Analysis

8.1 An analysis may be made by the purchaser on two lengths of pipe from each lot of 500 lengths, or fraction thereof. Samples for chemical analysis and the methods of analysis shall conform to the requirements of Test Methods, Practices, and Terminology A751. The chemical composition thus determined shall conform to the requirements specified in 6.1.

8.2 If the analysis of either pipe does not conform to the requirements of 6.1, analysis shall be made on additional lengths of pipe of double the original number from the same lot, each of which shall conform to the requirements specified.

## 9. Tensile Requirements

9.1 The material shall conform to the requirements as to tensile properties specified in Table 1.

**TABLE 1 Tensile Requirements**

	Butt Welded	Grade A	Grade B
Tensile strength, min, psi (MPa)	48 000 (330)	48 000 (330)	60 000 (415)
Yield strength, min, psi (MPa)	30 000 (205)	30 000 (205)	35 000 (240)
Elongation in 2 in.	A	A	A

<sup>A</sup> The minimum elongation in 2 in. (50.8 mm) shall be that determined by the following equation:

$$e = 625\,000 A^{0.2}/U^{0.9}$$

where:

- e = minimum elongation in 2 in. (50.8 mm) in percent rounded to the nearest 0.5 %.
- A = cross-sectional area of the tension test specimen in square inches, based on specified outside diameter or nominal specimen width and specified wall thickness rounded to the nearest 0.01 in.<sup>2</sup> If the area thus calculated is greater than 0.75 in.<sup>2</sup>, then the value 0.75 shall be used.
- U = specified tensile strength, psi.

9.2 The test specimen taken across the weld shall show a tensile strength not less than the minimum tensile strength specified for the grade of pipe ordered. This test is not required for pipe under 8 in. [DN 200] in outside diameter.

## 10. Dimensions, Weights, and Permissible Variations

10.1 The dimensions and weights of all types of pipe included in this specification are listed in Tables 2-17:

Type	Tables
I, Drive Pipe	Table 2, Table 3, Table 4, Table 5
II, Reamed and Drifted Pipe	Table 6, Table 7, Table 8, Table 9
III, Driven Well Pipe	Table 10, Table 11, Table 12, Table 13
IV, Water-Well Casing Pipe	Table 14, Table 15, Table 16, Table 17

### 10.2 Permissible Variations in Weight and Dimensions:

10.2.1 *Weight*—The weight of all types of pipe included in this specification shall vary not more than  $\pm 5\%$  from that prescribed. The weight tolerance for pipe NPS 4 [DN 100] and under may be determined from the weight of the customary lifts of pipe as produced for shipment, divided by the number of feet of pipe in the lift. For pipe over NPS 4 [DN 100], where individual lengths may be weighed, the weight is applicable to the individual length.

10.2.2 *Outside Diameter*—For pipe NPS 1½ [DN 40] and under, the outside diameters shall vary not more than 1/64 in. [0.4 mm] from the outside diameter specified. For pipe NPS 2 [DN 50] and over, the outside diameter shall vary not more than  $\pm 1\%$  from the size specified.

10.2.3 *Inside Diameter*—For Type II pipe, the inside diameter at any point, shall permit passage of a drift pin having a length and diameter as indicated in Table 6, Table 7, and Table 18.

10.2.4 *Thickness*—The minimum wall thickness shall be not more than 12.5 % under the nominal wall thickness specified.

### 10.3 Lengths:

10.3.1 Unless otherwise specified on the purchase order, pipe lengths shall be in accordance with the following regular practice:

10.3.1.1 Types I, II, and IV pipe may be furnished in single random lengths of 16 to 22 ft [4.9 to 6.7 m].

10.3.1.2 Type III pipe may be furnished in a random range from 3 to 6 ft [0.9 to 1.8 m] or 6 to 10 ft [1.8 to 3.0 m] as specified.

10.3.2 Random lengths other than indicated in 10.3.1 and cut lengths, shall be subject to negotiation and shall be indicated on the purchase order.

## 11. Ends

11.1 When ordered with plain ends, the pipe shall be furnished to the following practice unless otherwise specified.

11.1.1 *NPS 1½ [DN 40] and smaller*—Unless otherwise specified on the purchase order, end finish shall be at the option of the manufacturer.

**TABLE 2 Dimensions, Weights, and Test Pressures for Drive Pipe (Inch-Pound Units)**

NPS Designator	Weight per Foot, lb/ft		Wall Thickness, in.	Diameters, in.		No. of Threads per Inch	Couplings			Test Pressures, psi	
	Nominal Threads and Couplings	Calculated Plain Ends		Outside	Inside		Length, in.	Outside Diameter, in.	Calculated Weight, lb	Grade A	Grade B
6	19.45	18.97	0.280	6.625	6.065	8	5 $\frac{1}{8}$	7.290	13.35	1200	1300
8	25.55	24.70	0.277	8.625	8.071	8	6 $\frac{1}{8}$	9.625	26.89	1200	1300
8	29.35	28.55	0.322	8.625	7.981	8	6 $\frac{1}{8}$	9.625	26.89	1300	1600
8	32.40	31.27	0.354	8.625	7.917	8	6 $\frac{1}{8}$	9.625	26.89	1300	1600
10	32.75	31.20	0.279	10.750	10.192	8	6 $\frac{5}{8}$	11.750	36.05	940	1100
10	35.75	34.24	0.307	10.750	10.136	8	6 $\frac{5}{8}$	11.750	36.05	1000	1200
10	41.85	40.48	0.365	10.750	10.020	8	6 $\frac{5}{8}$	11.750	36.05	1200	1400
12	45.45	43.77	0.330	12.750	12.090	8	6 $\frac{5}{8}$	14.000	52.72	950	1100
12	51.15	49.56	0.375	12.750	12.000	8	6 $\frac{5}{8}$	14.000	52.72	1100	1200
14 D	57.00	54.57	0.375	14.000	13.250	8	7 $\frac{1}{8}$	15.000	50.22	950	1100
16 D	65.30	62.58	0.375	16.000	15.250	8	7 $\frac{1}{8}$	17.000	57.17	850	1000

**TABLE 3 Dimensions, Weights, and Test Pressures for Drive Pipe (SI Units)**

DN Designator	Weight per Foot, kg/m		Wall Thickness, mm	Diameters, mm		No. of Threads per 25.4 mm	Couplings			Test Pressures, kPa	
	Nominal Threads and Couplings	Calculated Plain Ends		Outside	Inside		Length, mm	Outside Diameter, mm	Calculated Weight, kg/m	Grade A	Grade B
150	28.94	28.23	7.11	168.3	154.1	8	130.18	185.17	19.86	8300	9 000
200	38.02	36.75	7.04	219.1	205.0	8	155.58	244.48	40.01	8300	9 000
200	43.67	42.48	8.18	219.1	202.7	8	155.58	244.48	40.01	9000	11 000
200	48.21	46.53	8.99	219.1	201.1	8	155.58	244.48	40.01	9000	11 000
250	48.73	46.43	7.09	273.1	258.9	8	168.28	298.45	53.64	6500	7 600
250	53.20	50.95	7.80	273.1	257.5	8	168.28	298.45	53.64	6900	8 300
250	62.27	60.23	9.27	273.1	254.5	8	168.28	298.45	53.64	8300	9 700
300	67.63	65.13	8.38	323.9	307.1	8	168.28	355.60	78.45	6600	7 600
300	76.11	73.75	9.53	323.9	304.8	8	168.28	355.60	78.45	7600	8 300
350	84.82	81.20	9.53	355.6	336.6	8	180.98	381.00	74.73	6600	7 600
400	97.17	93.12	9.53	406.4	387.4	8	180.98	431.80	85.07	5900	6 900

**TABLE 4 Basic Threading Data for Drive Pipe (Inch-Pound Units)**

1	2	3	4	5	6	7	8	9	10	11	12	13	14
Pipe				Threads <sup>A</sup>				Coupling					
NPS Designator	Outside Diameter, in.	Number per in.	Length, End of Pipe to Hand-tight Plane, in.	Effective Length, in.	Total Length, End of Pipe to Vanish Point, in.	Pitch Diameter at Hand-tight Plane, in.	Outside Diameter, in.	Length, in.	Diameter of Recess, in.	Depth of Recess, in.	Length, Face of Coupling to Hand-tight Plane, in.	Width of Bearing Face, in.	Hand-tight Standoff, Threads
	D <sup>B</sup>		L <sub>1</sub> <sup>B</sup>	L <sub>2</sub> <sup>B</sup>	L <sub>4</sub> <sup>B</sup>	E <sub>1</sub> <sup>B</sup>	W <sup>B</sup>	N <sub>L</sub> <sup>B</sup>	Q <sup>B</sup>	q <sup>B</sup>	M <sup>B</sup>	b <sup>B</sup>	A <sup>B</sup>
6	6.625	8	1.093	1.973	2.438	6.51375	7.390	5 $\frac{1}{8}$	6.719	$\frac{3}{8}$	0.595	$\frac{1}{4}$	6
8	8.625	8	1.593	2.473	2.938	8.51375	9.625	6 $\frac{1}{8}$	8.719	$\frac{3}{8}$	0.595	$\frac{1}{4}$	6
10	10.750	8	1.843	2.723	3.188	10.63875	11.750	6 $\frac{5}{8}$	10.844	$\frac{3}{8}$	0.595	$\frac{3}{8}$	6
12	12.750	8	1.843	2.723	3.188	12.63875	14.000	6 $\frac{5}{8}$	12.844	$\frac{3}{8}$	0.595	$\frac{3}{8}$	6
14 D	14.000	8	2.093	2.973	3.438	13.88875	15.000	7 $\frac{1}{8}$	14.094	$\frac{3}{8}$	0.595	$\frac{3}{8}$	6
16 D	16.000	8	2.093	2.973	3.438	15.88875	17.000	7 $\frac{1}{8}$	16.094	$\frac{3}{8}$	0.595	$\frac{3}{8}$	6

<sup>A</sup> Taper of threads is  $\frac{3}{16}$  in./ft on diameter for all sizes.

<sup>B</sup> See Fig. 1.

11.1.2 *NPS 2 [DN 50] and larger*—Unless otherwise specified on the purchase order, end finish shall be plain end beveled to an angle of  $30^\circ + 5^\circ$  and  $-0^\circ$ , as measured from a line drawn perpendicular to the axis of the pipe, with a root face of  $\frac{1}{16}$  in. [1.6 mm]  $\pm$   $\frac{1}{32}$  in. [0.8 mm].

11.2 When ordered threaded and coupled, each length of water well pipe shall be furnished with threaded ends and provided with a suitable coupling applied handling-tight. If couplings are required to be made up power tight, this shall be indicated on the purchase order.

**TABLE 5 Basic Threading Data for Drive Pipe (SI Units)**

1	2	3	4	5	6	7	8	9	10	11	12	13	14
Pipe			Threads <sup>A</sup>				Coupling						
DN Designator	Outside Diameter, mm	Number per 25.4 mm	Length, End of Pipe to Hand-tight Plane, mm	Effective Length, mm	Total Length, End of Pipe to Vanish Point, mm	Pitch Diameter at Hand-tight Plane, mm	Outside Diameter, mm	Length, mm	Diameter of Recess, mm	Depth of Recess, mm	Length, Face of Coupling to Hand-tight Plane, mm	Width of Bearing Face, mm	Hand-tight Standoff, Threads, mm
	D <sup>B</sup>		L <sub>1</sub> <sup>B</sup>	L <sub>2</sub> <sup>B</sup>	L <sub>4</sub> <sup>B</sup>	E <sub>1</sub> <sup>B</sup>	W <sup>B</sup>	N <sub>L</sub> <sup>B</sup>	Q <sup>B</sup>	q <sup>B</sup>	M <sup>B</sup>	b <sup>B</sup>	A <sup>B</sup>
150	168.28	8	27.76	50.11	61.93	165.45	187.71	130.18	170.66	9.53	15.11	6.35	6
200	219.08	8	40.46	62.81	74.63	216.25	244.48	155.58	221.46	9.53	15.11	6.35	6
250	273.05	8	46.81	69.16	80.98	270.22	298.45	168.28	275.44	9.53	15.11	9.53	6
300	323.85	8	46.81	69.16	80.98	321.02	355.60	168.28	326.24	9.53	15.11	9.53	6
350	355.60	8	53.16	75.51	87.33	352.77	381.00	180.98	357.99	9.53	15.11	9.53	6
400	406.40	8	53.16	75.51	87.33	403.57	431.80	180.98	408.79	9.53	15.11	9.53	6

<sup>A</sup> Taper of threads is 4.8 mm/305 mm on diameter for all sizes.

<sup>B</sup> See Fig. 1.

**TABLE 6 Dimensions, Weights, and Test Pressures for Water-Well Reamed and Drifted Pipe (Inch-Pound Units)**

NPS Designator	Weight per Foot, lb/ft		Wall Thickness, in.	Diameters, in.		No. of Threads per Inch	Couplings			Test Pressures, psi		
	Nominal Threads and Couplings	Calculated Plain Ends		Outside	In-side <sup>A</sup>		Length, in.	Outside Diameter, in.	Calculated Weight, lb	Butt Welded	Grade A	Grade B
1	1.70	1.68	0.133	1.315	1.049	11½	2¾	1.576	0.52	700	700	700
1¼	2.30	2.27	0.140	1.660	1.380	11½	2¾	1.900	0.60	1000	1000	1100
1½	2.75	2.72	0.145	1.900	1.610	11½	2¾	2.200	0.84	1000	1000	1100
2	3.75	3.65	0.154	2.375	2.067	11½	3⅞	2.750	1.58	1000	2300	2500
2	4.00	3.94	0.167	2.375	2.041	11½	3⅞	2.750	1.58	1000	2500	2500
2½	5.90	5.79	0.203	2.875	2.469	8	3⅞	3.250	2.32	1000	2500	2500
3	7.70	7.58	0.216	3.500	3.068	8	4⅞	4.000	3.80	1000	2200	2500
3½	9.25	9.11	0.226	4.000	3.548	8	4⅞	4.625	5.53	1200	2000	2400
4	11.00	10.79	0.237	4.500	4.026	8	4⅞	5.200	7.14	1200	1900	2200
5	15.00	14.62	0.258	5.563	5.047	8	4½	6.296	9.57	1200	1700	1900
6	19.45	18.97	0.280	6.625	6.065	8	4⅞	7.390	12.32	...	1500	1800
8	29.35	28.55	0.322	8.625	7.981	8	5⅞	9.625	22.35	...	1300	1600
10	41.85	40.48	0.365	10.750	10.020	8	5⅞	11.750	30.61	...	1200	1400
12	51.15	49.56	0.375	12.750	12.000	8	5⅞	14.000	47.96	...	1100	1200

<sup>A</sup> Drift pin dimensions (see Table 18)

11.3 The basic thread dimensions for each type of water well pipe are shown in Table 4, Table 5, Table 8, Table 9, Table 12, Table 13, Table 16, and Table 17. An illustration of the joint of each type of water well pipe is shown in Figs. 1-4.

11.4 For Type III pipe, the threads on the pipe ends are interchangeable with either the standard pipe coupling, the reamed and drifted pipe coupling, or the API line pipe coupling. Orders for this class material shall indicate the coupling class desired.

11.4.1 Standard pipe couplings shall be manufactured in accordance with Specification A865.

11.4.2 Line pipe couplings shall be manufactured in accordance with API 5L Specification for Line Pipe.

11.5 The threads on the pipe ends not protected by a coupling shall be suitably protected against damage in normal handling and transit conditions.

11.6 The length of the pipe shall be measured to the outer face of the coupling.

## 12. Finish

12.1 The finished pipe shall be reasonably straight and free of defects. Any imperfection that exceeds 12½ % of the nominal wall thickness, or violates minimum wall shall be considered a defect.

12.2 The pipe ends shall be free of burrs. The zinc coating on galvanized pipe shall be free of voids or excessive roughness.

## 13. Galvanized Pipe

13.1 For the types of water well pipe required with galvanized coating, such coating shall comply with the requirements of the latest revision of Specification A53/A53M.

**TABLE 7 Dimensions, Weights, and Test Pressures for Water-Well Reamed and Drifted Pipe (SI Units)**

DN Designator	Weight per Foot, kg/m		Wall Thickness, mm	Diameters, mm		No. of Threads per 25.4 mm	Couplings			Test Pressures, kPa		
	Nominal Threads and Couplings	Calculated Plain Ends		Out-side	In-side <sup>A</sup>		Length, mm	Outside Diameter, mm	Calculated Weight, Kg	Butt Welded	Grade A	Grade B
25	2.53	2.50	3.38	33.4	26.6	11½	69.85	40.03	0.77	4900	4 800	4 800
32	3.42	3.38	3.56	42.2	35.1	11½	69.85	48.26	0.89	6900	6 900	7 600
40	4.09	4.05	3.68	48.3	40.9	11½	69.85	55.88	1.25	6900	6 900	7 600
50	5.58	5.43	3.91	60.3	52.5	11½	85.73	69.85	2.35	6900	15 900	17 200
50	5.95	5.86	4.24	60.3	51.8	11½	85.73	69.85	2.35	6900	17 200	17 200
65	8.78	8.62	5.16	73.0	62.7	8	100.01	82.55	3.45	6900	17 200	17 200
80	11.46	11.28	5.49	88.9	77.9	8	103.19	101.60	5.65	6900	15 200	17 200
90	13.76	13.56	5.74	101.6	90.1	8	106.36	117.48	8.23	8300	13 800	16 500
100	16.37	16.06	6.02	114.3	102.3	8	109.54	132.08	10.62	8300	13 100	15 200
125	22.32	21.75	6.55	141.3	128.2	8	114.30	159.92	14.24	8300	11 700	13 100
150	28.94	28.23	7.11	168.3	154.1	8	119.06	187.71	18.33	...	10 300	12 400
200	43.67	42.48	8.18	219.1	202.7	8	128.59	244.48	33.26	...	8 900	11 000
250	62.27	60.23	9.271	273.1	254.5	8	141.29	298.45	45.55	...	8 300	9 700
300	76.11	73.75	9.525	323.9	304.8	8	150.81	355.60	71.36	...	7 600	8 300

<sup>A</sup> Drift pin dimensions (see Table 18)

**TABLE 8 Basic Threading Data for Water-Well Reamed and Drifted Pipe (Inch-Pound Units)**

1	2	3	4	5	6	7	8	9	10	11	12	13	14
Pipe		Threads <sup>A</sup>						Coupling					
NPS Designator	Outside Diameter, in.	Number per Inch	Length, End of Pipe to Hand-tight Plane, in.	Effective Length, in.	Total Length, End of Pipe to Vanish Point, in.	Pitch Diameter at Hand-tight Plane, in.	Outside Diameter, in.	Length, in.	Diameter of Recess, in.	Depth of Recess, in.	Length, Face of Coupling to Hand-tight Plane, in.	Width of Bearing Face, in.	Hand-tight Standoff, Threads, in.
	D <sup>B</sup>		L <sub>1</sub> <sup>B</sup>	L <sub>2</sub> <sup>B</sup>	L <sub>4</sub> <sup>B</sup>	E <sub>1</sub> <sup>B</sup>	W <sup>B</sup>	NL <sup>B</sup>	Q <sup>B</sup>	q <sup>B</sup>	M <sup>B</sup>	b <sup>B</sup>	A <sup>B</sup>
1	1.315	11½	0.4811	0.6828	0.9845	1.24369	1.576	2¾	1.378	0.1875	0.5034	¼ <sub>16</sub>	0
1¼	1.660	11½	0.5051	0.7068	1.0085	1.58869	1.900	2¾	1.723	0.1875	0.5034	¼ <sub>16</sub>	0
1½	1.900	11½	0.5218	0.7235	1.0252	1.82869	2.200	2¾	1.963	0.1875	0.5034	¾ <sub>32</sub>	0
2	2.375	11½	0.7012	0.9884	1.2901	2.29835	2.750	3¾	2.469	0.1875	0.5889	¾ <sub>32</sub>	0
2½	2.875	8	0.9342	1.1375	1.5712	2.77792	3.250	3½ <sub>16</sub>	2.969	0.1875	0.6370	¾ <sub>32</sub>	0
3	3.500	8	0.9967	1.2000	1.6337	3.40292	4.000	4¼ <sub>16</sub>	3.594	0.1875	0.6370	½	0
3½	4.000	8	1.0467	1.2500	1.6837	3.90292	4.625	4¾ <sub>16</sub>	4.094	0.1875	0.6370	¾ <sub>16</sub>	0
4	4.500	8	1.0967	1.3000	1.7337	4.40292	5.200	4½ <sub>16</sub>	4.594	0.1875	0.6370	¼	0
5	5.563	8	1.2030	1.4063	1.8400	5.46592	6.296	4½	5.657	0.1875	0.6370	¼	0
6	6.625	8	1.3092	1.5125	1.9462	6.52792	7.390	4¼ <sub>16</sub>	6.719	0.1875	0.6370	¼	0
8	8.625	8	1.5092	1.7125	2.1462	8.52792	9.625	4¼ <sub>16</sub>	8.719	0.1875	0.6370	¼	0
10	10.750	8	1.7217	1.9250	2.3587	10.65292	11.750	5¾ <sub>16</sub>	10.844	0.1875	0.6370	¾	0
12	12.750	8	1.9217	2.1250	2.5587	12.65292	14.000	5¼ <sub>16</sub>	12.844	0.1875	0.6370	¾	0

<sup>A</sup> Taper of threads is ¾ in. /ft on diameter for all sizes.

<sup>B</sup> See Fig. 2

## 14. Number of Tests

14.1 One longitudinal or transverse tension test of seamless and welded pipe, and in addition, one transverse weld test for electric-welded pipe NPS 8 [DN 200] and larger, shall be made on one length of pipe from each lot of 500 lengths, or fraction thereof, of each size. A length is defined as the length as ordered, except that in the case of orders for lengths shorter than single random, the term lot shall apply to the lengths as rolled, prior to cutting to the required short lengths.

14.2 Each length of pipe shall be subjected to the hydrostatic test as indicated for the type, size, and grade as shown in Tables 4-15. The hydrostatic pressure shall be maintained for not less than 5 s for all sizes of seamless and electric-resistance-welded pipe.

## 15. Retests

15.1 If the results of the tension tests of any lot do not conform to the requirements of Table 1, the lot shall be

**TABLE 9 Basic Threading Data for Water-Well Reamed and Drifted Pipe (SI Units)**

1	2	3	4	5	6	7	8	9	10	11	12	13	14
Pipe		Threads <sup>A</sup>				Coupling							
DN Designator	Outside Diameter, mm	Number per 25.4 mm	Length, End of Pipe to Hand-tight Plane, mm	Effective Length, mm	Total Length, End of Pipe to Vanish Point, mm	Pitch Diameter at Hand-tight Plane, mm	Outside Diameter, mm	Length, mm	Diameter of Recess, mm	Depth of Recess, mm	Length, Face of Coupling to Hand-tight Plane, mm	Width of Bearing Face, mm	Hand-tight Standoff, Threads, mm
	D <sup>B</sup>		L <sub>1</sub> <sup>B</sup>	L <sub>2</sub> <sup>B</sup>	L <sub>4</sub> <sup>B</sup>	E <sub>1</sub> <sup>B</sup>	W <sup>B</sup>	NL <sup>B</sup>	Q <sup>B</sup>	q <sup>B</sup>	M <sup>B</sup>	b <sup>B</sup>	A <sup>B</sup>
25	33.4	11 ½	12.22	17.34	25.01	31.59	40.03	69.85	35.00	4.76	12.79	1.59	0
32	42.2	11 ½	12.83	17.95	25.62	40.35	48.26	69.85	43.76	4.76	12.79	1.59	0
40	48.3	11 ½	13.25	18.38	26.04	46.45	55.88	69.85	49.86	4.76	12.79	2.38	0
50	60.3	11 ½	17.81	25.11	32.77	58.38	69.85	85.73	62.71	4.76	14.96	2.38	0
65	73.0	8	23.73	28.89	39.91	70.56	82.55	100.01	75.41	4.76	16.18	2.38	0
80	88.9	8	25.32	30.48	41.50	86.43	101.60	103.19	91.29	4.76	16.18	3.18	0
90	101.6	8	26.59	31.75	42.77	99.13	117.48	106.36	103.99	4.76	16.18	4.76	0
100	114.3	8	27.86	33.02	44.04	111.83	132.08	109.54	116.69	4.76	16.18	6.35	0
125	141.3	8	30.56	35.72	46.74	138.83	159.92	114.30	143.69	4.76	16.18	6.35	0
150	168.3	8	33.25	38.42	49.43	165.81	187.71	119.06	170.66	4.76	16.18	6.35	0
200	219.1	8	38.33	43.50	54.51	216.61	244.48	119.06	221.46	4.76	16.18	6.35	0
250	273.1	8	43.73	48.90	59.91	270.58	298.45	141.29	275.44	4.76	16.18	9.53	0
300	323.9	8	48.81	53.98	64.99	321.38	355.60	150.81	326.24	4.76	16.18	9.53	0

<sup>A</sup> Taper of threads is 19 mm/305 mm on diameter for all sizes.

<sup>B</sup> See Fig. 2

**TABLE 10 Dimensions,<sup>A</sup> Weights,<sup>A</sup> and Test Pressures for Driven Well Pipe (Inch-Pound Units)**

NPS Designator	Weight per Foot, lb/ft		Wall Thickness, in.	Diameters, in.		No. of Threads per Inch	Coupling		Test Pressures, psi	
	Nominal Threads and Couplings	Calculated Plain Ends		Outside	Inside <sup>A</sup>		Calculated Weight, lb	Butt Welded	Grade A	Grade B
1	1.68	1.68	0.133	1.315	1.049	11½	0.40	700	700	700
1¼	2.28	2.27	0.140	1.660	1.380	11½	0.48	1000	1000	1100
1½	2.73	2.72	0.145	1.900	1.610	11½	0.67	1000	1000	1100
2	3.68	3.65	0.154	2.375	2.067	11½	1.05	1000	2300	2500

<sup>A</sup> Nominal T & C weights shown are based on the standard pipe coupling. For pipe weights with reamed and drifted coupling applied, see Table 8 of this specification. For weights with the line pipe coupling applied refer to API Standard 5L.

**TABLE 11 Dimensions,<sup>A</sup> Weights,<sup>A</sup> and Test Pressures for Driven Well Pipe (SI Units)**

DN Designator	Weight per Foot, kg/m		Wall Thickness, mm	Diameters, mm		No. of Threads per 25.4 mm	Coupling		Test Pressures, kPa	
	Nominal Threads and Couplings	Calculated Plain Ends		Outside	Inside <sup>A</sup>		Calculated Weight, kg	Butt Welded	Grade A	Grade B
25	2.50	2.50	3.38	33.40	26.64	11 ½	0.60	4800	4 800	4 800
32	3.39	3.38	3.56	42.16	35.05	11 ½	0.71	6900	6 900	7 600
40	4.06	4.05	3.68	48.26	40.89	11 ½	1.00	6900	6 900	7 600
50	5.48	5.43	3.91	60.33	52.50	11 ½	1.56	6900	15 900	17 200

<sup>A</sup> Nominal T & C weights shown are based on the standard pipe coupling. For pipe weights with reamed and drifted coupling applied, see Table 9 of this specification. For weights with the line pipe coupling applied refer to API Standard 5L.

rejected, or retests shall be made on additional pipe of double the original number from the same lot, each of which shall conform to the requirements specified.

## 16. Test Methods

16.1 The tension tests required shall conform to those described in the latest issue of Test Methods and Definitions **A370**.

16.1.1 The longitudinal tension test specimen shall be taken from the end of the pipe and for welded pipe the specimen may be taken from the skelp or strip, at a point approximately 90° from the weld and shall not be flattened between gage marks. The sides of each specimen shall be parallel between gage marks.

**TABLE 12 Basic Threading Data<sup>A</sup> for Driven Well Pipe (Inch-Pound Units)**

1	2	3	4	5	6	7	8	9	10
Pipe		Threads				Joint Make-up			
NPS Designator	Outside Diameter, in.	Number per Inch	Length, End of Pipe to Hand-tight Plane, in.	Effective Length, in.	Total Length, End of Pipe to Vanish Point, in.	Pitch Diameter at Handtight Plane, in.	Length, Face of Coupling to Handtight Plane, in.	Width of Bearing Face, in.	Handtight Standoff, Threads, in.
	D <sup>B</sup>		L <sub>1</sub> <sup>B</sup>	L <sub>2</sub> <sup>B</sup>	L <sub>4</sub> <sup>B</sup>	E <sub>1</sub> <sup>B</sup>	M <sup>B</sup>	b <sup>B</sup>	A <sup>B</sup>
1	1.315	11½	0.400	0.6828	0.9845	1.23863	0.1304	approximately ⅓	5.22
1¼	1.660	11½	0.420	0.7068	1.0085	1.58338	0.1304	thickness of	5.27
1½	1.900	11½	0.420	0.7235	1.0252	1.82234	0.1304	coupling	5.46
2	2.375	11½	0.436	0.7565	1.0582	2.29627	0.1304		5.66

<sup>A</sup> Based on standard-weight pipe with standard coupling. For basic threading data of reamed and drifted coupling see [Table 10](#) of this specification. For line pipe coupling refer to API Standard 5L.

<sup>B</sup> See [Fig. 3](#).

**TABLE 13 Basic Threading Data<sup>A</sup> for Driven Well Pipe (SI Units)**

1	2	3	4	5	6	7	8	9	10
Pipe		Threads				Joint Make-up			
DN Designator	Outside Diameter, mm	Number per 25.4 mm	Length, End of Pipe to Hand-tight Plane, mm	Effective Length, mm	Total Length, End of Pipe to Vanish Point, mm	Pitch Diameter at Handtight Plane, mm	Length, Face of Coupling to Handtight Plane, mm	Width of Bearing Face, in.	Handtight Standoff, Threads, mm
	D <sup>B</sup>		L <sub>1</sub> <sup>B</sup>	L <sub>2</sub> <sup>B</sup>	L <sub>4</sub> <sup>B</sup>	E <sub>1</sub> <sup>B</sup>	M <sup>B</sup>	b <sup>B</sup>	A <sup>B</sup>
25	33.40	11 ½	10.16	17.34	25.01	31.46	3.31	approximately ⅓	132.59
32	42.16	11 ½	10.67	17.95	25.62	40.22	3.31	⅓ thickness	133.86
40	48.26	11 ½	10.67	18.38	26.04	46.29	3.31	of coupling	138.68
50	60.33	11 ½	11.07	19.22	26.88	58.33	3.31		143.76

<sup>A</sup> Based on standard-weight pipe with standard coupling. For basic threading data of reamed and drifted coupling see [Table 11](#) of this specification. For line pipe coupling refer to API Standard 5L.

<sup>B</sup> See [Fig. 3](#).

**TABLE 14 Dimensions, Weights, and Test Pressures for Water-Well Casing (Inch-Pound Units)**

Size, Outside Diameter, in.	Weight per Foot, lb/ft		Wall Thickness, in.	Diameters, in.		No. of Threads per Inch	Couplings			Test Pressures, psi
	Threads and Couplings	Plain Ends		Outside	Inside		Length, in.	Outside Diameter, in.	Calculated Weight, lb	
3.500	4.60	4.51	0.125	3.500	3.250	14	3⅞	4.000	2.86	1100
4.000	5.65	5.53	0.134	4.000	3.732	14	3⅞	4.500	3.24	1000
4.500	6.75	6.61	0.142	4.500	4.216	14	3⅞	5.000	4.26	950
5.500	9.00	8.79	0.154	5.500	5.192	14	4⅞	6.050	6.38	850
6.000	10.50	10.22	0.164	6.000	5.672	14	4⅞	6.625	7.84	850
6.625	13.00	12.72	0.185	6.625	6.255	11½	4⅞	7.390	11.88	850
8.625	17.80	16.90	0.188	8.625	8.249	11½	5¼	9.625	22.92	650

16.1.2 Transverse weld test specimen from electric-welded pipe shall be taken with the weld at the center of the specimen. All transverse test specimens shall be 1½ in. [38 mm] wide in the gage length and shall represent the full wall thickness of the pipe from which the specimen was cut.

16.1.3 All specimens shall be tested at room temperature.

## 17. Hydrostatic Test

17.1 Each length of pipe shall be tested at the mill to the hydrostatic pressures as prescribed for each type of pipe in [Table 2](#), [Table 3](#), [Table 6](#), [Table 7](#), [Table 10](#), [Table 11](#), [Table 14](#), and [Table 15](#). The hydrostatic test may be applied at the

discretion of the manufacturer on pipe with plain ends, with threads only, or with threads and coupling.

## 18. Inspection

18.1 The inspector representing the purchaser shall have entry, at all times while work on the contract of the purchaser is being performed, to all parts of the manufacturer's works that concern the manufacture of the material ordered. The manufacturer shall afford the inspector all reasonable facilities to satisfy him that the material is being furnished in accordance with this specification. All tests and inspection shall be made at the place of manufacture prior to shipment unless otherwise

**TABLE 15 Dimensions, Weights, and Test Pressures for Water-Well Casing (SI Units)**

Size, Outside Diameter, mm	Weight per Foot, kg/m		Wall Thickness, mm	Diameters, mm		No. of Threads per 25.4 mm	Couplings			Test Pressures, kPa
	Threads and Couplings	Plain Ends		Outside	Inside		Length, mm	Outside Diameter, mm	Calculated Weight, kg/m	
88.9	6.84	6.71	3.18	88.9	82.6	14	79.38	101.60	4.26	7600
101.6	8.41	8.23	3.40	101.6	94.8	14	79.38	114.30	4.82	6900
114.3	10.04	9.84	3.61	114.3	107.1	14	92.08	127.00	6.34	6600
139.7	13.39	13.08	3.91	139.7	131.9	14	104.78	153.67	9.49	5900
152.4	15.62	15.21	4.17	152.4	144.1	14	104.78	168.28	11.67	5900
168.3	19.34	18.93	4.70	168.3	158.9	11 ½	117.48	187.71	17.68	5900
219.1	26.49	25.15	4.78	219.1	209.5	11 ½	133.35	244.48	34.10	4500

**TABLE 16 Basic Threading Data for Water-Well Casing (Inch-Pound Units)**

1	2	3	4	5	6	7	8	9	10	11	12	13
Threads, in. <sup>A</sup>							Coupling, in.					
Size, Outside Diameter, in.	Number per Inch	Length, End of Pipe to Hand-tight Plane, in.	Effective Length, in.	Total Length, End of Pipe to Vanish Point, in.	Pitch Diameter at Hand-tight Plane, in.	Outside Diameter, in.	Length, in.	Diameter of Recess, in.	Depth of Recess, in.	Length, Face of Coupling to Hand-tight Plane, in.	Width of Bearing Face, in.	Hand-tight Standoff, in.
3 ½	14	0.5241	1.0455	1.3071	3.4296	4.000	3 ⅞	3 ⅞	¼	0.426	5/32	5
4	14	0.5741	1.0955	1.3571	3.9296	4.500	3 ⅞	4 ⅞	¼	0.426	5/32	5
4 ½	14	0.6241	1.1455	1.4071	4.4296	5.000	3 ⅞	4 ⅞	¼	0.426	5/32	5
5 ½	14	0.7241	1.2455	1.5071	5.4296	6.050	4 ⅞	5 ⅞	¼	0.426	5/32	5
6	14	0.7741	1.2955	1.5571	5.9296	6.625	4 ⅞	6 ⅞	¼	0.426	5/32	5
6 ⅝	11 ½	0.9123	1.3784	1.6973	6.5445	7.390	4 ⅞	6 ⅞	¼	0.437	3/16	4
8 ⅝	11 ½	1.1123	1.5784	1.8973	8.5445	9.625	5 ¼	6 ⅞	¼	0.437	3/16	4

<sup>A</sup> Taper of threads is 3/8 in./ft on diameter for all sizes.

**TABLE 17 Basic Threading Data for Water-Well Casing (SI Units)**

1	2	3	4	5	6	7	8	9	10	11	12	13
Threads <sup>A</sup>							Coupling					
Size, Outside Diameter, mm	Number per 25.4 mm	Length, End of Pipe to Hand-tight Plane, mm	Effective Length, mm	Total Length, End of Pipe to Vanish Point, mm	Pitch Diameter at Hand-tight Plane, mm	Outside Diameter, mm	Length, mm	Diameter of Recess, mm	Depth of Recess, mm	Length, Face of Coupling to Hand-tight Plane, mm	Width of Bearing Face, mm	Hand-tight Standoff, mm
88.90	14	13.31	26.56	33.20	87.11	101.60	79.38	91.28	6.35	10.82	3.97	5
101.60	14	14.58	27.83	34.47	99.81	114.30	79.38	103.98	6.35	10.82	3.97	5
114.30	14	15.85	29.10	35.74	112.51	127.00	92.08	116.68	6.35	10.82	3.97	5
139.70	14	18.39	31.64	38.28	137.91	153.67	104.78	142.08	6.35	10.82	3.97	5
152.40	14	19.66	32.91	39.55	150.61	168.28	104.78	154.78	6.35	10.82	3.97	5
168.28	11 ½	23.17	35.01	43.11	166.23	187.71	117.48	170.66	6.35	11.10	4.76	4
219.08	11 ½	28.25	40.09	48.19	217.03	244.48	133.35	170.66	6.35	11.10	4.76	4

<sup>A</sup> Taper of threads is 9.53 mm/305 mm on diameter for all sizes.

specified, and shall be so conducted as not to interfere unnecessarily with the operation of the works.

## 19. Rejection

19.1 Each length of pipe received from the manufacturer may be inspected by the purchaser and, if it does not meet the requirements of this specification based on the inspection and test method as outlined in the specification, the length may be rejected and the manufacturer shall be notified. Disposition of

**TABLE 18 Drift Pin Dimensions**

NPS Designator [DN]	Length of Pin, in. [mm]	Diameter of Pin, in. [mm], Smaller Than Nominal Inside Diameter of Pipe
To 6 [DN 150], incl	12 [305]	3/32 [2.38]
8 [DN 200], 10 [DN 250], and 12 [DN 300]	12 [305]	1/8 [3.18]



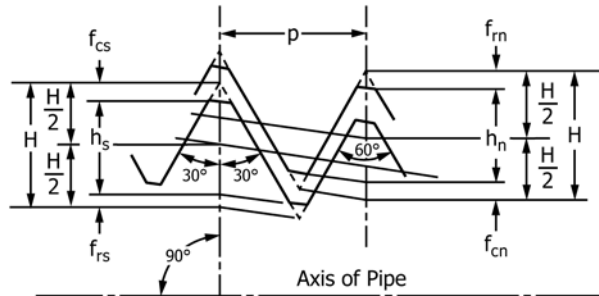
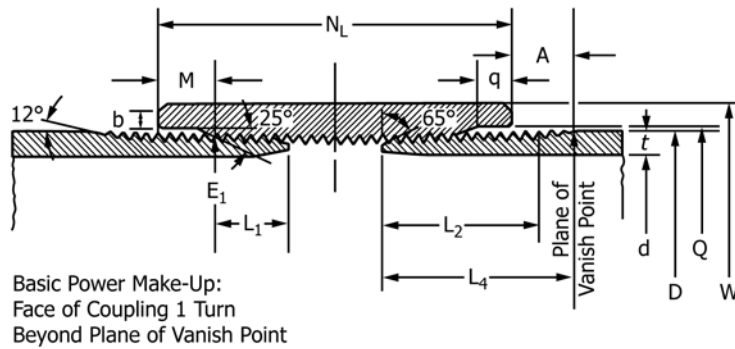

**Taper 1 in 64 on Diameter**  
(Shown Exaggerated in Diagram)

Thread Height Dimensions, in.

Thread Element	in.	mm
	8 Threads per Inch $p = 0.125$	8 Threads per 25.4 mm $p = 3.175$
$H = 0.866p$	0.1082	2.748
$h_s = h_n = 0.760p$	0.0950	2.413
$f_{rs} = f_{rn} = 0.033p$	0.0041	0.1041
$f_{cs} = f_{cn} = 0.073p$	0.0091	0.2311

**FIG. 1 Basic Threading Data for Drive Pipe (Handling-Tight Assembly) (See Tables 4 and 5)**

rejected pipe shall be a matter of agreement between the manufacturer and the purchaser.

19.2 Pipe found in fabrication or in installation to be unsuitable for the intended use, under the scope and requirements of this specification, may be set aside and the manufacturer notified. Such pipe shall be subject to mutual investigation as to the nature and severity of the deficiency and the forming or installation, or both, conditions involved. Disposition shall be a matter for agreement.

**20. Certification**

20.1 The producer or supplier shall, upon request, furnish to the purchaser a certification of inspection stating that the material has been manufactured, sampled, tested, and inspected in accordance with this specification (including the year date designation) and has been found to meet the requirements.

**21. Product Marking**

21.1 Each length of pipe shall be legibly marked by rolling, stamping, or stenciling to show: the name or brand of the manufacturer, type number, the kind of pipe (butt-welded, electric-resistance-welded, or seamless), grade, nominal or

outside diameter size, wall thickness, the specification number and the length. Length shall be marked in feet and tenths of a foot or metres to two decimal places, depending on the units to which the material was ordered or other marking subject to agreement.

21.2 Marking shall begin approximately 12 in. [305 mm] from the coupling of each length.

21.3 Type II pipe NPS 1½ [DN 40] and under and for all sizes of Type III pipe, the required marking as specified in 21.1 may be applied to a tag securely attached to the bundle or bale prepared for shipment.

NOTE 2—When pipe sections are cut into shorter lengths by a subsequent processor for resale as material, the processor shall transfer complete identifying information to each unmarked cut length, or to metal tags securely attached to bundles of unmarked small diameter pipe. The same material designation shall be included with the information transferred, and the processor’s name, trademark, or brand shall be added.

21.4 *Bar Coding*—In addition to the requirements in 21.1, 21.2, and 21.3, bar coding is acceptable as a supplemental identification method. The purchaser may specify in the order a specific bar coding system to be used.

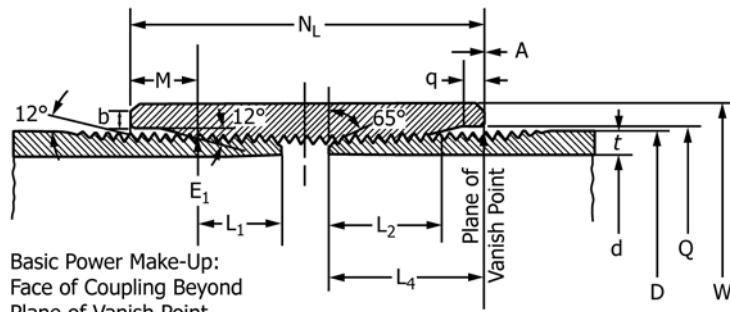

Basic Power Make-Up:  
 Face of Coupling Beyond  
 Plane of Vanish Point  
 3-Turns on Sizes 2" and Smaller  
 2-Turns on Sizes 2½" and Larger

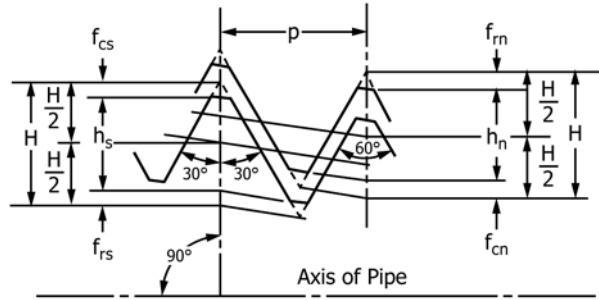

**Taper 1 in 16 on Diameter**  
 (Shown Exaggerated in Diagram)

Thread Height Dimensions, in.

Thread Element	in.	mm	in.	mm
	11½ Threads per Inch $p = 0.0870$	11½ Threads per 25.4 mm $p = 2.209$	8 Threads per Inch $p = 0.125$	8 Threads per 25.4 mm $p = 3.175$
$H = 0.866p$	0.0753	1.913	0.1082	2.748
$h_s = h_n = 0.760p$	0.0661	1.679	0.0950	2.413
$f_{rs} = f_{rm} = 0.033p$	0.0029	0.074	0.0041	0.104
$f_{cs} = f_{cn} = 0.073p$	0.0063	0.160	0.0091	0.231

FIG. 2 Basic Threading Data for Water-Well Reamed and Drifted Pipe (Handling-Tight Assembly) (See Tables 8 and 9)

**22. Packaging**

22.1 All types and sizes of water well pipe may be shipped loose except that NPS 1½ [DN 40] and smaller sizes of Type II pipe and all sizes of Type III pipe shall be packaged in bundles or bales of convenient size for handling.

22.2 If special packaging is required for any pipe size, such requirements shall be negotiated and the required practice shall be indicated on the purchase order.

**23. Keywords**

23.1 carbon steel pipe; seamless steel pipe; steel pipe; water well pipe; welded steel pipe

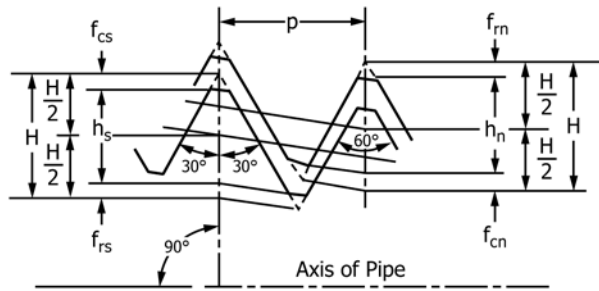
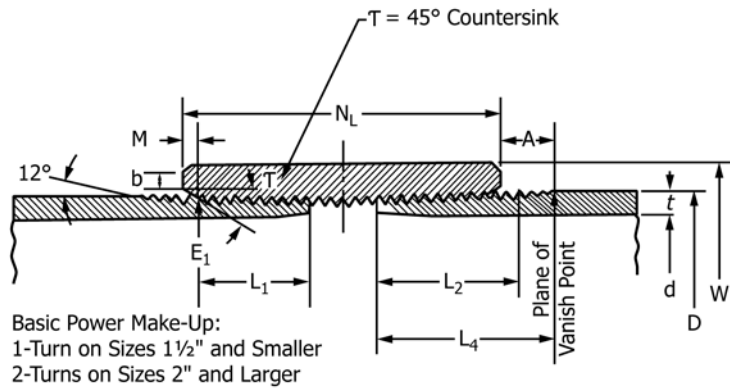

**Taper 1 in 16 on Diameter**  
 (Shown Exaggerated in Diagram)

Thread Height Dimensions, in.

Thread Element	in.	mm
	11½ Threads per Inch $p = 0.0870$	11½ Threads per 25.4 mm $p = 2.209$
$H = 0.866p$	0.0753	1.913
$h_s = h_n = 0.760p$	0.0661	1.679
$f_{rs} = f_{rn} = 0.033p$	0.0029	0.074
$f_{cs} = f_{cn} = 0.073p$	0.0063	0.160

**FIG. 3 Basic Threading Data for Driven Well Pipe (Handling-Tight Assembly) (See Tables 12 and 13)**

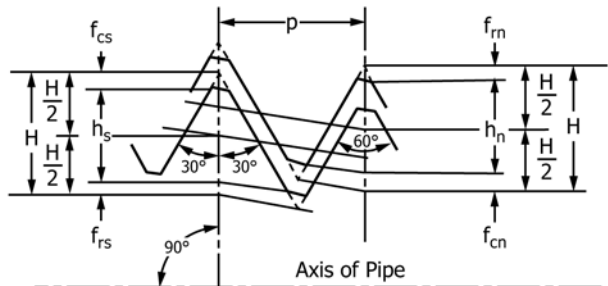
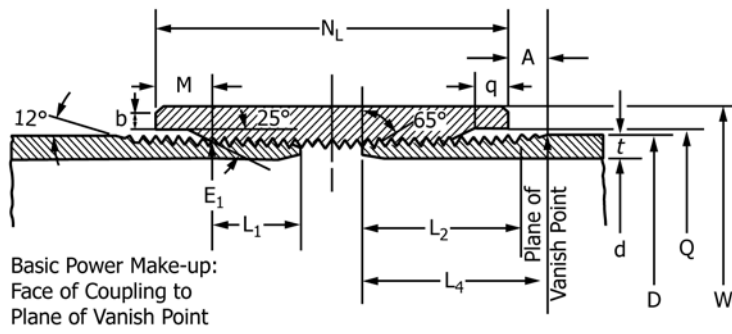

**Taper 1 in 32 on Diameter**  
(Shown Exaggerated in Diagram)

Thread Height Dimensions, in.

Thread Element	in.		mm	
	14 Threads per Inch $p = 0.0714$	14 Threads per 25.4 mm $p = 1.814$	11½ Threads per Inch $p = 0.0870$	11½ Threads per 25.4 mm $p = 2.209$
$H = 0.866p$	0.0619	1.572	0.0753	1.913
$h_s = h_n = 0.760p$	0.0543	1.379	0.0661	1.679
$f_{rs} = f_{rm} = 0.033p$	0.0024	0.061	0.0029	0.074
$f_{cs} = f_{cn} = 0.073p$	0.0052	0.132	0.0063	0.160

**FIG. 4 Basic Threading Data for Water-Well Casing (Handling-Tight Assembly) (See Tables 16 and 17)**

**SUMMARY OF CHANGES**

Committee A01 has identified the location of selected changes to this specification since the last issue, A589 – 96(2001), that may impact the use of this specification. (Approved March 1, 2006)

- (1) Added metric dimensions in the text.
- (2) Added metric tables for all “inch-pound” tables.
- (3) Deleted old Table 2 and renumbered subsequent tables and references.

*ASTM International takes no position respecting the validity of any patent rights asserted in connection with any item mentioned in this standard. Users of this standard are expressly advised that determination of the validity of any such patent rights, and the risk of infringement of such rights, are entirely their own responsibility.*

*This standard is subject to revision at any time by the responsible technical committee and must be reviewed every five years and if not revised, either reapproved or withdrawn. Your comments are invited either for revision of this standard or for additional standards and should be addressed to ASTM International Headquarters. Your comments will receive careful consideration at a meeting of the responsible technical committee, which you may attend. If you feel that your comments have not received a fair hearing you should make your views known to the ASTM Committee on Standards, at the address shown below.*

*This standard is copyrighted by ASTM International, 100 Barr Harbor Drive, PO Box C700, West Conshohocken, PA 19428-2959, United States. Individual reprints (single or multiple copies) of this standard may be obtained by contacting ASTM at the above address or at 610-832-9585 (phone), 610-832-9555 (fax), or service@astm.org (e-mail); or through the ASTM website (www.astm.org). Permission rights to photocopy the standard may also be secured from the Copyright Clearance Center, 222 Rosewood Drive, Danvers, MA 01923, Tel: (978) 646-2600; http://www.copyright.com/*